

RECTANGULAR DIOPTER SERIES (4"X 5.65" MATTE BOX)

Professional optical tools are one of our core competencies, and we have taken great lengths to provide cinematographers with a complete set of high quality diopters housed in 4"x 5.65" frames that slide quickly and easily into any top-loaded and side-loaded matte box (Arri, Chrosziel, etc.) since the handle can be mounted either on top or sideways. The Standard Diopter Set consists of three diopters with magnification strengths of +0.5, +0.8 and +2.0.

We understand how important time is on the set, and since working with traditional round diopters and donuts can be time consuming, we decided to offer a solution that does not only save time on the set, but also provides Directors of Photography with new creative opportunities. We used expensive, high-end glass to create these thin, rectangular diopters. All our +0.5 and +0.8 diopters use a single filter slot, and the +2.0 diopters uses double filter slots.



TECHNICAL DATA

	Height	Width	Thickness	Weight lbs
0.5 dpt	4.7"	5.9"	0,25"	0,46 lbs
0.8 dpt	4.7"	5.9"	0,25"	0,73 lbs
2.0 dpt	4.7"	5.9"	0,49	1,39 lbs

	Height	Width	Thickness	Weight kg
0.5 dpt	120 mm	150 mm	6,3 mm	210 g
0.8 dpt	120 mm	150 mm	6,3 mm	330 g
2.0 dpt	120 mm	150 mm	12,5 mm	630 g

▲ DO NOT TILT +0.8 DPT

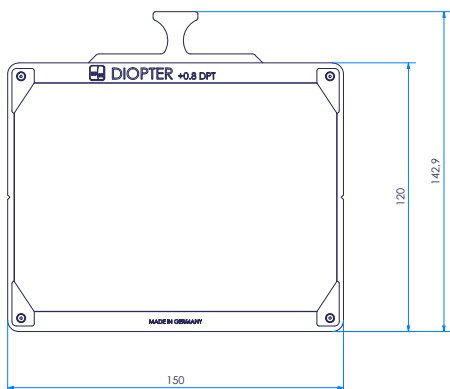

▲ DO NOT TILT +2.0 DPT

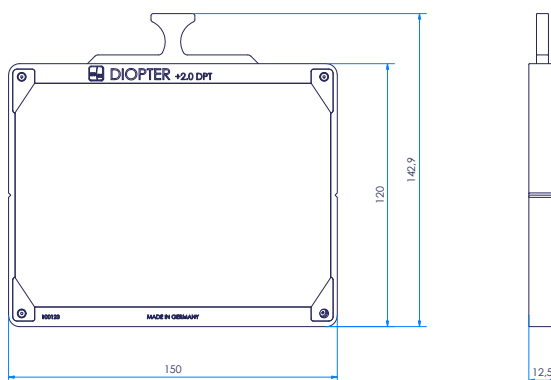

Do NOT TILT when pulling out!