



Anbauverdichter



www.steck.de



YouTube



Facebook



Instagram



TikTok

Anbauverdichter AVH2R - AVH12R



Technische Daten	AVH2R	AVH5R	AVH8R	AVH12R
Gewicht (kg)	200	495	820	1.200
Impulskraft (t)	3	4	6,5	15
max. Vibrationsfrequenz (Rpm)	2.000	2.000	2.000	2.200
Ölfluss (l/min)	30 - 60	45 - 75	85 - 120	120 - 170
Ölfluss drehen (l/min)	25	25	25	25
Betriebsdruck (bar)	100 - 130	100 - 130	120 - 180	150 - 200
Drehen (bar)	320	320	320	320
Arbeitsfläche (mm)	600x370x25	850x560x25	1050x700x25	1350x900x30
Höhe (mm)	400	550	700	1500
Baggergewicht (t)	1,5 - 3	4 - 12	8 - 20	17 - 30

Produktmerkmale:

Kompakt-Rotator (Schnecke, Drehkranzsystem oder Ölmotor)

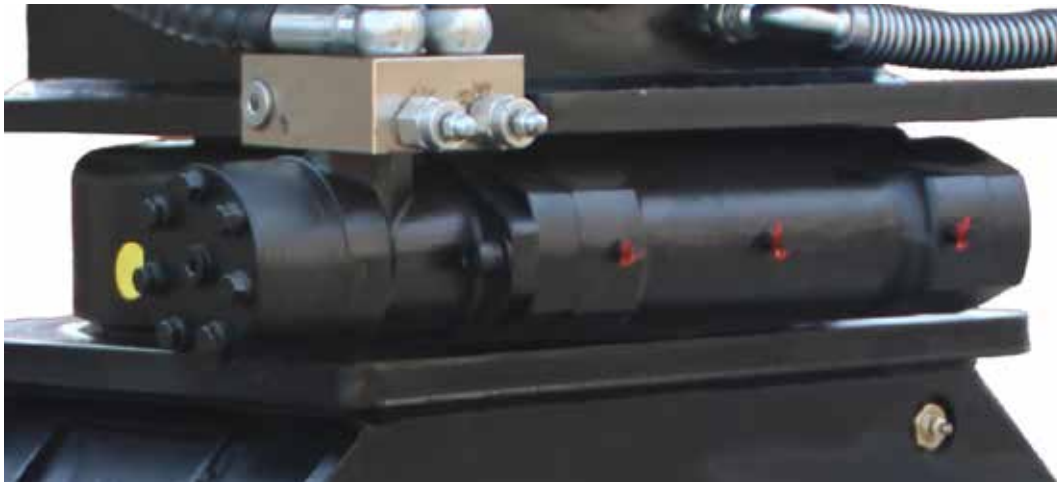

Zubehör:

- ermöglicht das Verdichten zwischen den Schwellen und unterhalb der Schienen
- einfache Montage auf der Baustelle möglich

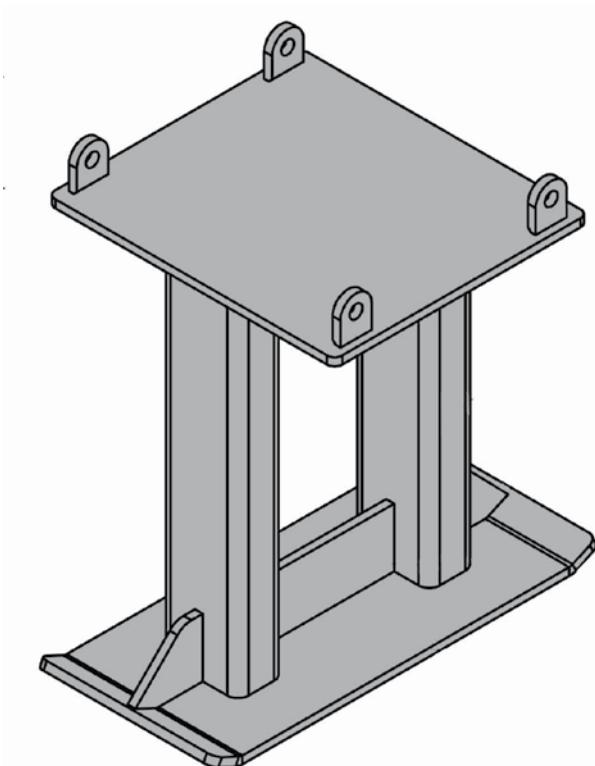

Steck Abbruchgeräte GmbH
Hauptstr. 20
D- 89192 Rammingen

Tel. +49 (0) 7345 9123 - 0
Fax +49 (0) 7345 9123 - 20
E-Mail info@steck.de
Internet www.steck.de

Ihr Ansprechpartner:

