

PAUL 7 NITRO

PRECISE - **A**GILE - **U**LTRA **L**IGHT

Bauanleitung und Handbuch V 1.0 / Assembly Instruction and Manual V 1.1

INHALT / CONTENT

Technische Daten & Sicherheitshinweise / Specifications & Safety Instructions

Benötigtes Werkzeug & Allgemeine Hinweise / Required Tools & General Information

Bauanleitung und Handbuch / Assembly Instructions and Manual

SEHR GEEHRTER KUNDE

BESTEN DANK, DASS SIE SICH FÜR DEN soXos PAUL 7 NITRO ENTSCHIEDEN HABEN.

Bevor Sie mit dem Zusammenbau oder der Inbetriebnahme beginnen,
lesen Sie diese Anleitung bitte sorgfältig durch!

DEAR CUSTOMER,

THANK YOU FOR CHOOSING THE soXos PAUL 7 NITRO MODEL HELICOPTER.

Before beginning with the assembly or operating the helicopter,
please read this manual thoroughly!

Technische Daten

Hier die wesentlichen Merkmale:

- Gewicht (mit Standard Komponenten ohne Sprit): 3700g
- Gewicht (ohne Komponenten und Blätter): 2025g
- Hauptrotordurchmesser: 1560mm mit 700mm Blätter
- Hauptrotorblätter: 685-710mm
- Heckrotorblätter: 105mm
- Länge: 1360mm
- Höhe: 342mm
- Getriebeübersetzung Hauptrotor: 1:8.01
- Getriebeübersetzung Heckrotor: 1:5.05
- Tankvolumen: 600ccm
- Motor: 90er bis 105er Nitro-Motor OS oder YS
- TS-Servos: Standard 40mm (Optional Midi Grösse 35mm)
- Heckservo: Standard Grösse 40mm
- Gasservo: Standard 40mm oder Midi Grösse 35mm

Empfohlene Komponenten:

- Heck- und Haupt-Rotorblätter
- Flybarless-System
- Motor: 90er bis 105er OS oder YS
- Schalldämpfer
- TS-Servos 3stk.: min. 14kg/cm
- Heckservo: min. 6kg/cm
- Gasservo: 35mm oder 40mm
- Akku für Stromversorgung
- Sender / Empfänger

Specifications

Here are the key features:

- Weight (with standard components, without fuel): 3700g
- Weight (without components and blades): 2025g
- Main Rotor Diameter: 1560mm with 700mm Blades
- Main Blades: 685-710mm
- Tail Blades: 105mm
- Length: 1360mm
- Height: 342mm
- Gear Ratio Main Rotor: 1:8.01
- Gear Ratio Tail Rotor: 1:5.05
- Fuel Tank volume: 600ccm
- Engine: 90 to 105 Nitro Engine OS or YS
- Cyclic Servos: Standard size 40mm (Optional Midi size 35mm)
- Tail Servo: Standard size 40mm
- Throttle Servo: Standard size 40mm or Midi size 35mm

Recommended components:

- Tail and Main Blades
- Flybarless system
- Motor: 90 to 105 Nitro Engine OS or YS
- Muffler
- Cyclic Servos 3pcs.: min.14kg/cm
- Tail Servo: min. 6kg / cm
- Throttle Servo: 35mm or 40mm
- RC-Battery
- Transmitter / Receiver



Sicherheitshinweise:

Ein Modellhubschrauber ist kein Spielzeug, sondern ein sehr leistungsfähiges Flugmodell, das bei unsachgemäßer Bedienung und Wartung grossen Schaden an Mensch und Material verursachen kann. Kinder und Jugendliche sollten einen Modellhubschrauber nur unter Aufsicht eines sachkundigen Erwachsenen bedienen. Heli Professional kann für Haftungs- und Nachfolgeschäden von und mit Erzeugnissen aus dem Lieferprogramm nicht aufkommen und lehnt deshalb jegliche Haftung ab, da ein ordnungsgemäßer Betrieb oder Einsatz unsererseits nicht überwacht werden kann. Zudem bitten wir Sie, sich an die Bedienungsanleitung zu halten und nur Originalersatzteile von Heli Professional zu verwenden.



Safety Instructions:

A model helicopter is a very powerful flying device and not a toy. Disregarding our instructions, inappropriate use, and insufficient maintenance by persons lacking necessary competence may result in injuries for the user and can cause damage to the surroundings and to the model. Children and adolescents should operate a model helicopter only under supervision of an experienced adult. Heli Professional will not accept responsibility for any damage caused by their products and rejects any liability as we are not in a position to supervise proper operation, handling, and maintenance by the user. Furthermore, we ask you to follow our operating and assembly instructions carefully and to use only original Heli Professional parts.

Benötigtes Werkzeug/Required Tools



Innensechskantschlüssel
Hexagon Socket Wrenches
SW 1.5/2/2.5/3



Schraubensicherungs-lack, mittelfest und fest
Threadlocker, medium and strong

Sekundenkleber
CA (Cyanoacrylic Instant Adhesive)

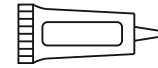

Gabelschlüssel 5.5/8/15mm
Flat Wrench

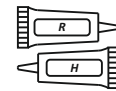
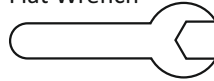

2 Komponenten Kleber
2-Component Adhesive

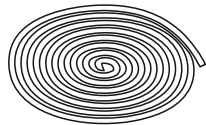

Schnur ca. 2m
String



Fett
Grease

Steckschlüssel 12/21mm
Socket Wrench

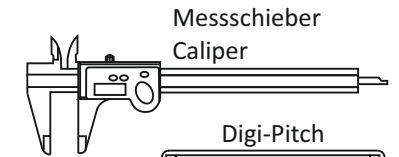

Messschieber
Caliper

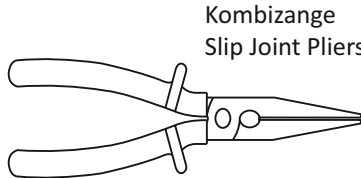

Kombizange
Slip Joint Pliers

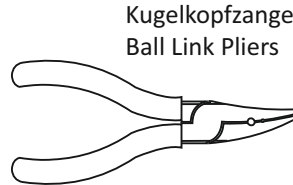

Kugelpkopfzange
Ball Link Pliers

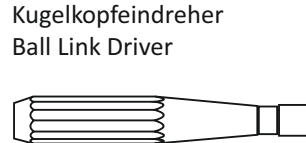

Kugelpkopfeindreher
Ball Link Driver

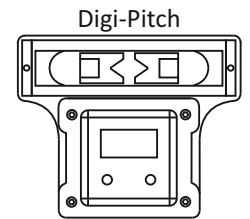

Digi-Pitch

Allgemeine Hinweise/General Information

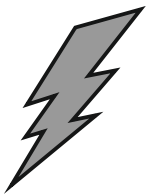

WICHTIG: Bevor Sie mit dem Zusammenbau oder der Inbetriebnahme beginnen, lesen Sie diese Anleitung bitte sorgfältig durch!

IMPORTANT: Before beginning with the assembly or operating the helicopter, please read this manual thoroughly!

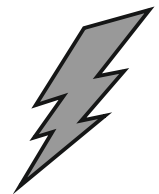

- Es sind keine elektronischen Bauteile, wie z.B. Servos, etc. im Lieferumfang enthalten.
- The kit does not include any electronic components such as servos, etc.

- Grundsätzlich muss jede Schraube entfettet und mit Sicherungslack eingeklebt werden. Auch bereits vormontierte Teile müssen diesbezüglich kontrolliert werden. Das rechts abgebildete Symbol soll Sie während des Zusammenbaus daran erinnern. Kugellager werden NICHT eingeklebt, ausser es wird darauf hingewiesen.
- In general, every screw must be cleaned and secured with threadlocker. Also, check preassembled parts regarding this. The symbol on the right-hand side is supposed to remind you while going through the assembly process. Ball bearings must NOT be secured with threadlocker except where noted.

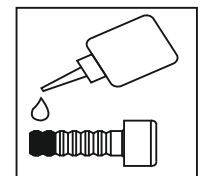

1:1

- Die in den Bauabschnitten mit diesem Symbol abgebildeten Schrauben, etc. sind in Originalgrösse dargestellt.
- The screws and all other parts depicted with this symbol in the assembly steps are actual-size drawings.

- Achten Sie auf die Freigängigkeit aller verbauten Kugellager und Drucklager.
- Check all ball bearings and thrust bearings for ease of movement.

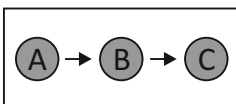
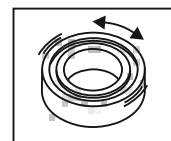

- Montieren Sie die Bauteile in der angegebenen Reihenfolge.
- Assemble the parts in the specified order.



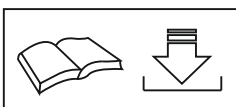

- Wiederholen Sie den Montageschritt so oft wie angegeben (hier: zwei Mal).
- Repeat the assembly step as often as specified (here: twice).

2x



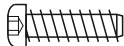

- Handbücher und Bauanleitungen für Tuningteile sind direkt von der Webseite zu beziehen.
- Manuals and assembly instructions for tuning parts are to be downloaded directly from the website. www.soxos-heli.com

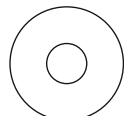
Normteile/Standard Parts

- 8 3x12 Treibschraube Self Tapping Screw 2x

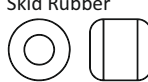
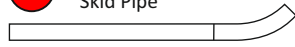
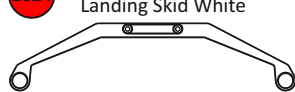
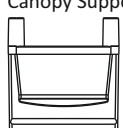
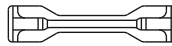
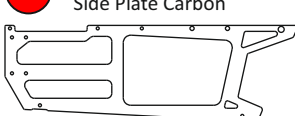
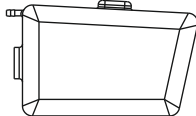
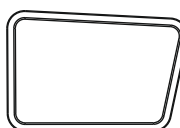
- 92 M3x6 Gewindestift Set Screw 4x

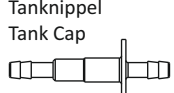
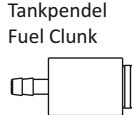
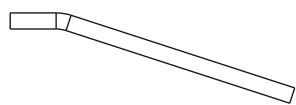
- 354 M3x8 Rundkopfschraube Round Head Screw 8x

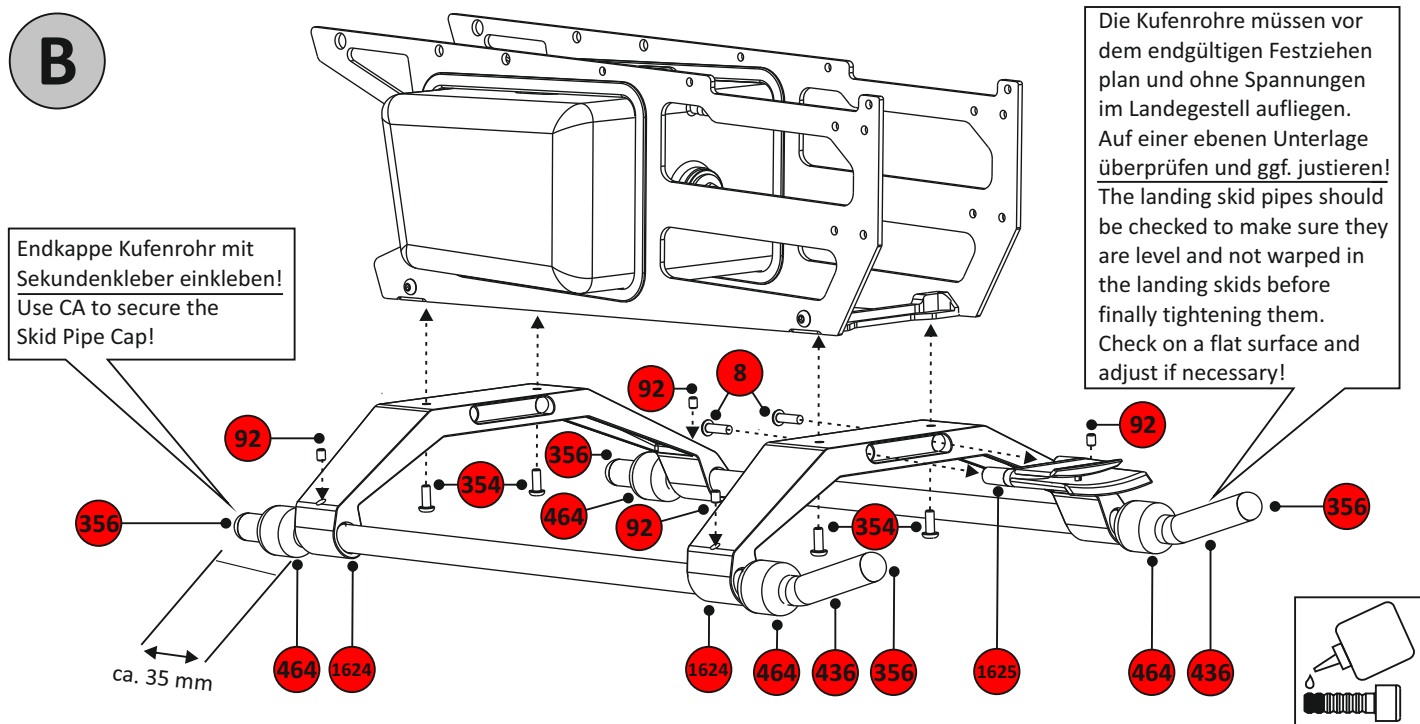
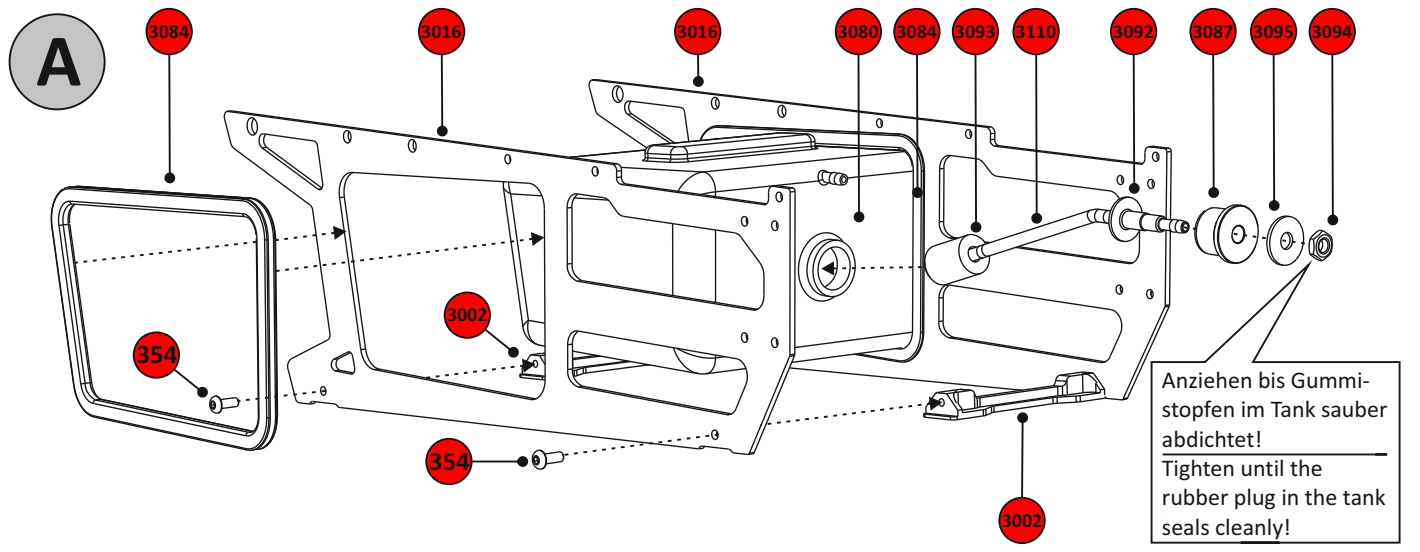
- 3094 M5 Mutter Nut 1x

- 3095 5.3x15x1.2 Unterlagsscheibe Washer 1x

1:1

- 356 Endkappe Kufenrohr Skid Pipe Cap 4x

- 464 Kufengummi Skid Rubber 4x

- 436 Kufenrohr Skid Pipe 2x

- 1624 Landegestell Weiss Landing Skid White 2x

- 1625 Haubenhaltung Canopy Support landing skid 1x

- 3002 Kufenhalterung Landing Skid Holder 2x

- 3016 Carbon Seitenplatte Side Plate Carbon 2x

- 3080 Kraftstofftank Fuel Tank 1x

- 3084 Gummiprofil Rubber Profile 2x

- 3087 Gummistopfen Rubber Plug 1x

- 3092 Tanknippel Tank Cap 1x

- 3093 Tankpendel Fuel Clunk 1x

- 3110 Kraftstoffschlauch Fuel Tube 1x



Normteile/Standard Parts

142	M3x22 Schraube Hex Socket Screw	2x	1706	Distanzhülse Distance Sleeve	2x
105	M3x18 Schraube Hex Socket Screw	1x	1741	Feder U-Scheibe Spring Washer	1x
354	M3x8 Rundkopfschraube Round Head Screw	8x	1738	Distanzhülse Distance Sleeve	1x
1705	3x8x3 Flanschlager Flanged Bearing	6x			

1:1

417	10x19x5 Kugellager Ball Bearing	2x	3014	Halte Platte Holder Plate	1x
1680-01	Heckriemenführung Tail Belt Guide	2x	3060	Kugellager Platte oben Bearing Plate upper	1x
1742	Zugfeder Extension Spring	1x	3061	Kugellager Platte unten Bearing Plate lower	1x
1744-1	Klemmhebel Gripping Lever	1x	3065	Distanzhülse Shim Sleeve	1x

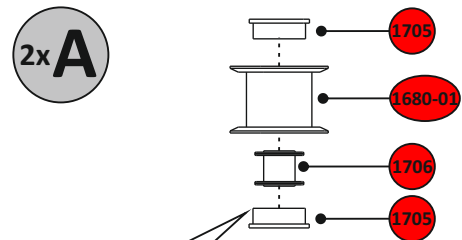

2x A

Alle Kugellager in der Baugruppe A und B mit Sicherungslack einkleben!
Glue all ball bearings in the assembly A and B with strong threadlocker!

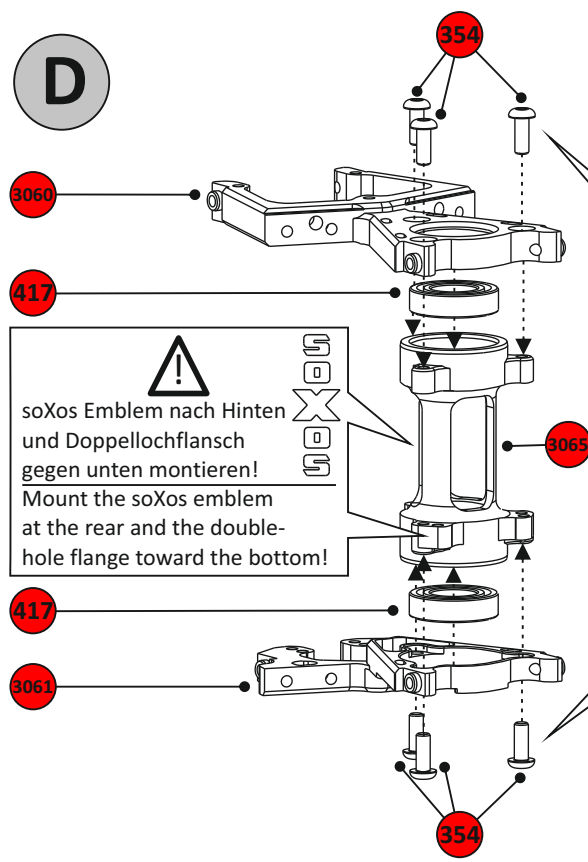
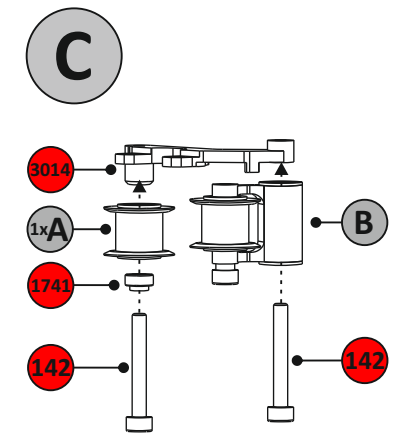
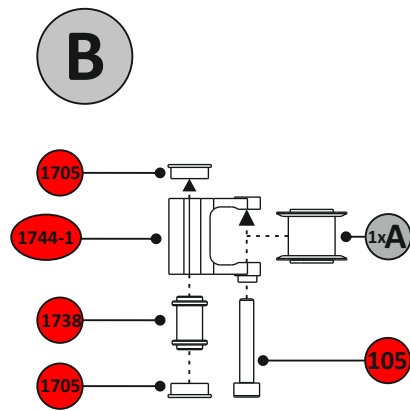



soXos Emblem nach Hinten und Doppellochflansch gegen unten montieren!
Mount the soXos emblem at the rear and the double-hole flange toward the bottom!

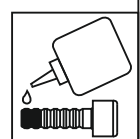
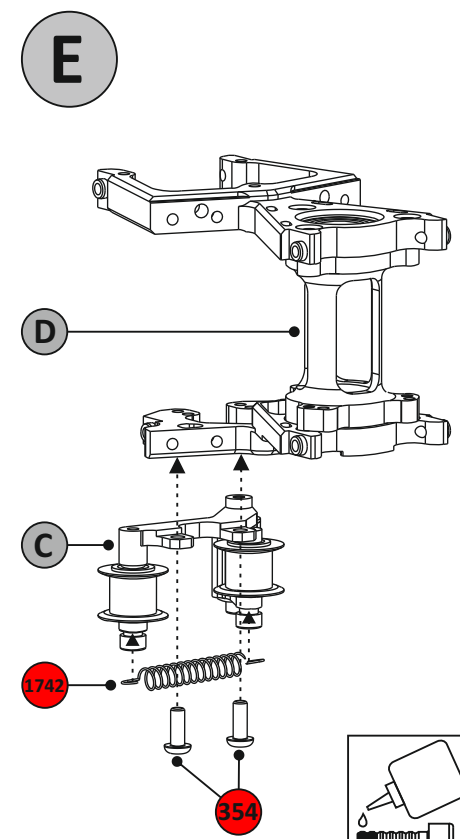



Schrauben erst leicht eindrehen, danach gleichmässig anziehen!
First lightly seat the screws, then tighten them evenly!

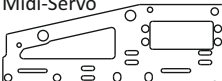

Normteile/Standard Parts

- 303 M3x8 Zylinderkopfschraube 8x
 Socket Head Screw

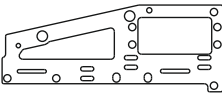
- 302 M3x5 Rundkopfschraube 4x
 Round Head Screw

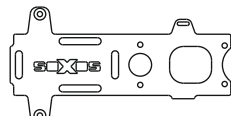
- 1639 M3x5 Senkschraube 2x
 Countersunk Screw

1:1

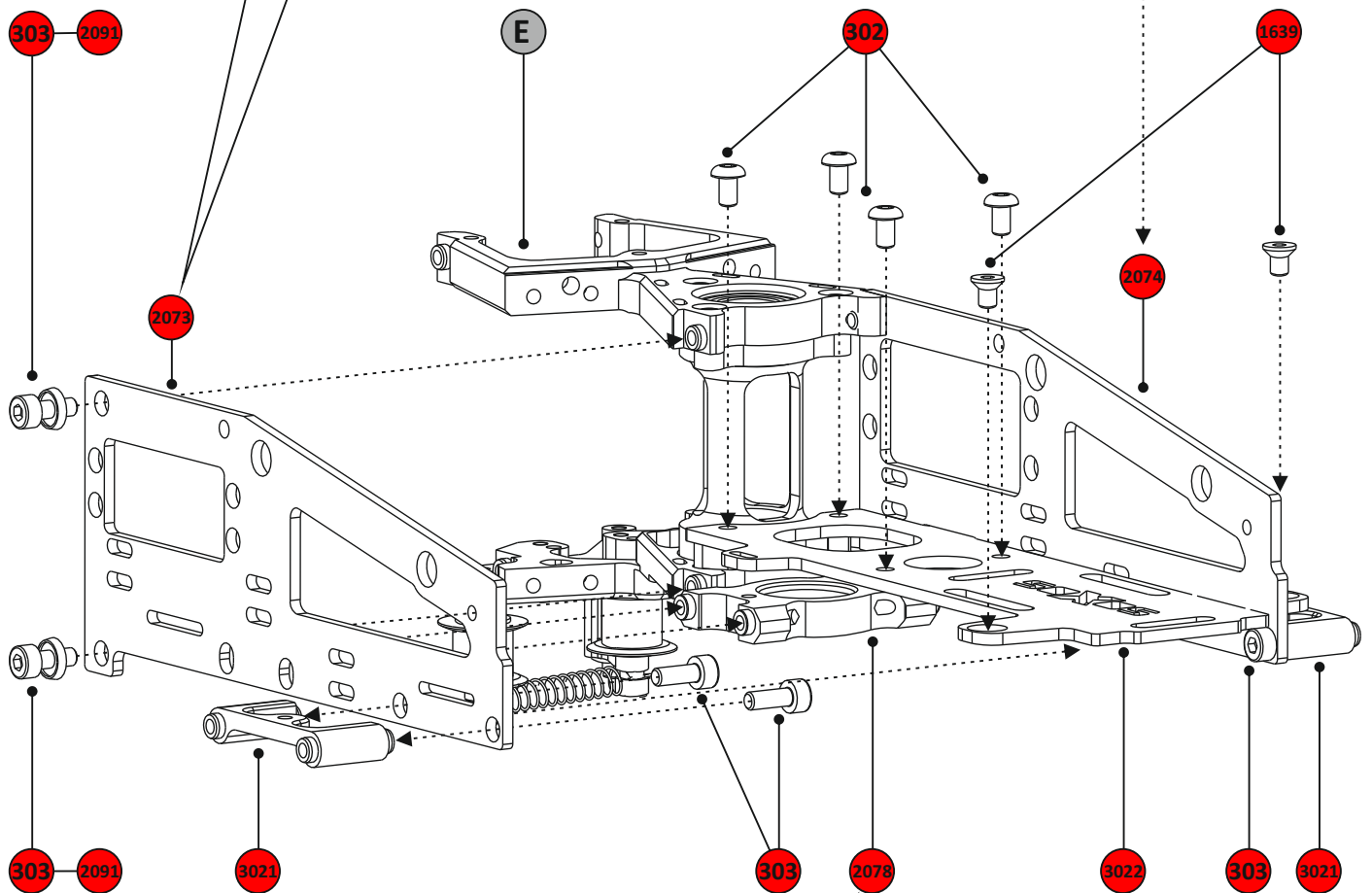
- 2073 Seitenplatte vorne Nitro 1x
 Side Plate front Nitro

- 2078 Lager Platte 1x
 Bearing Plate

- 3021 Distanzhalter 2x
 Distance Rail

- 2074 Seitenplatte vorne Nitro 1x
 Side Plate front Nitro
 Standard-Servo

- 2091 U-Scheibe 4x
 Washer

- 3022 Vorbau N 1x
 Porch Plate N



 Bei Verwendung von TS Midi-Servos,
 2073 und 2074 tauschen!
 When using Cyclic Midi servos,
 swap sides for 2073 and 2074!





 Große Öffnung nach unten für
 spätere Kugellagermontage!
 Large opening at the bottom for
 subsequent ball bearing installation!

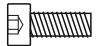

Normteile/Standard Parts

303 M3x8 Zylinderkopfschraube 24x
Socket Head Screw



1639 M3x5 Senkschraube 4x
Countersunk Screw



1:1

2072 Seitenplatte hinten 2x
Side Plate back

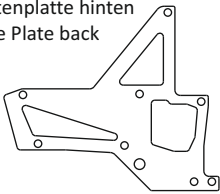

2088 Flybarless Platte 1x
Flybarless Plate

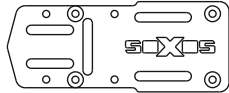

2091 U-Scheibe 22x
Washer



3018 Halter vorne 2x
Rail Front

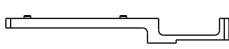

3004 Seitenplatte 1x
Side Plate Carbon
Standard-Servo

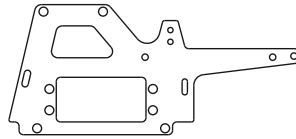

3052 Seitenplatte 1x
Side Plate Carbon
Midi-Servo

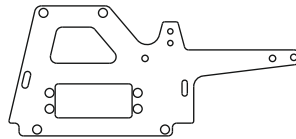

3057 Heckrohrhalter 1x
Tail Boom Holder





3058 Heckrohrhalter 1x
Tail Boom Holder

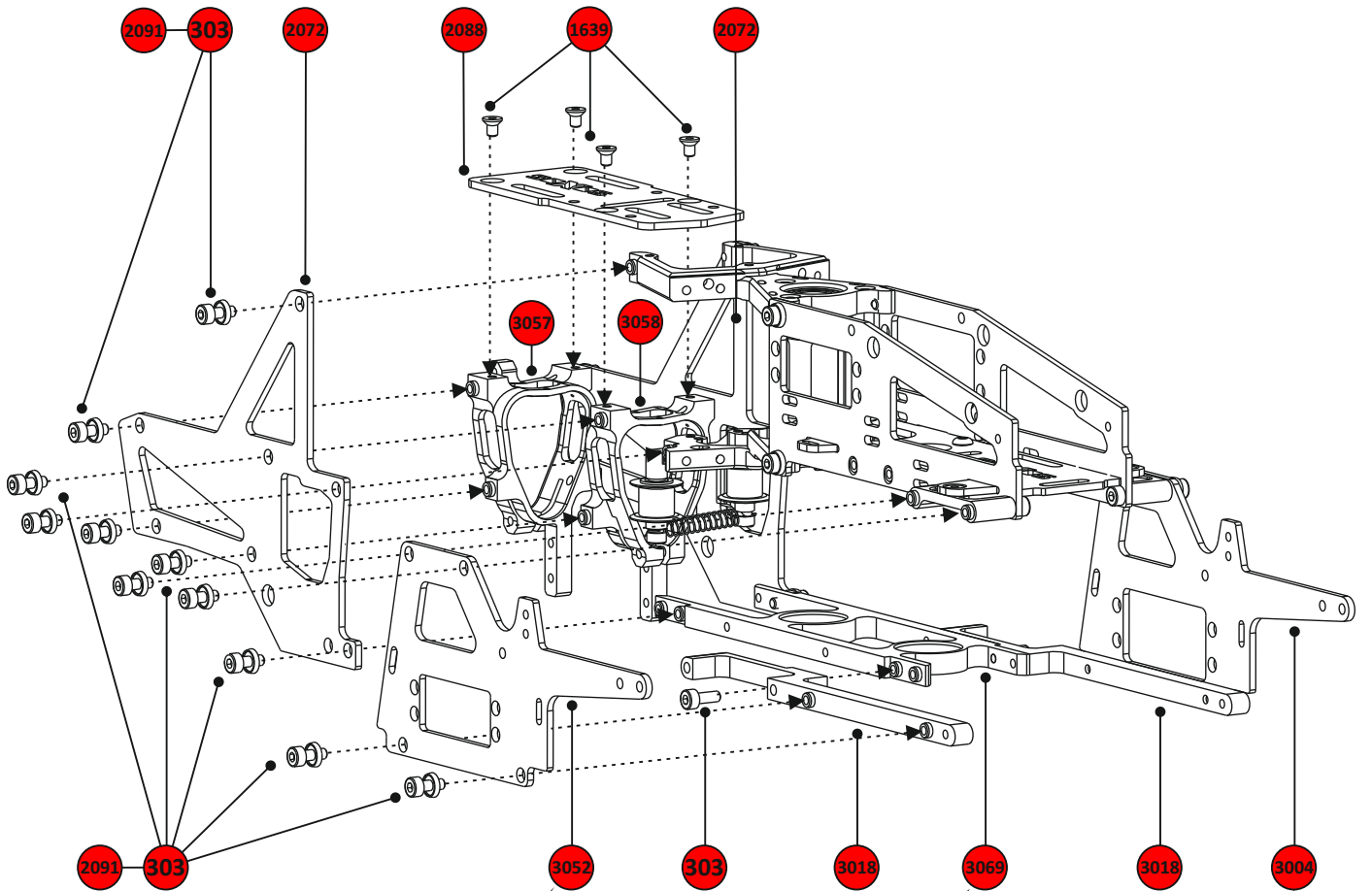
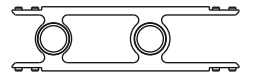

3069 Halte Platte 1x
Bearing Plate





 Bei Verwendung von Midi-Servos für das Gas, 3052 und 3004 tauschen!
When using Midi servos for the throttle, swap sides for 3052 and 3004!



 Große Öffnung nach oben für spätere Kugellagermontage!
Large opening at the top for subsequent ball bearing installation!

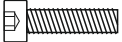

Normteile/Standard Parts

- 142 M3x22 Schraube Hex Socket Screw 8x

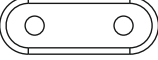
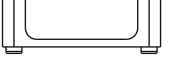
- 149 M3x12 Zylinderkopfschraube 8x Socket Head Screw

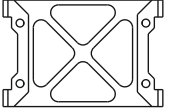
- 303 M3x8 Zylinderkopfschraube 2x Socket Head Screw

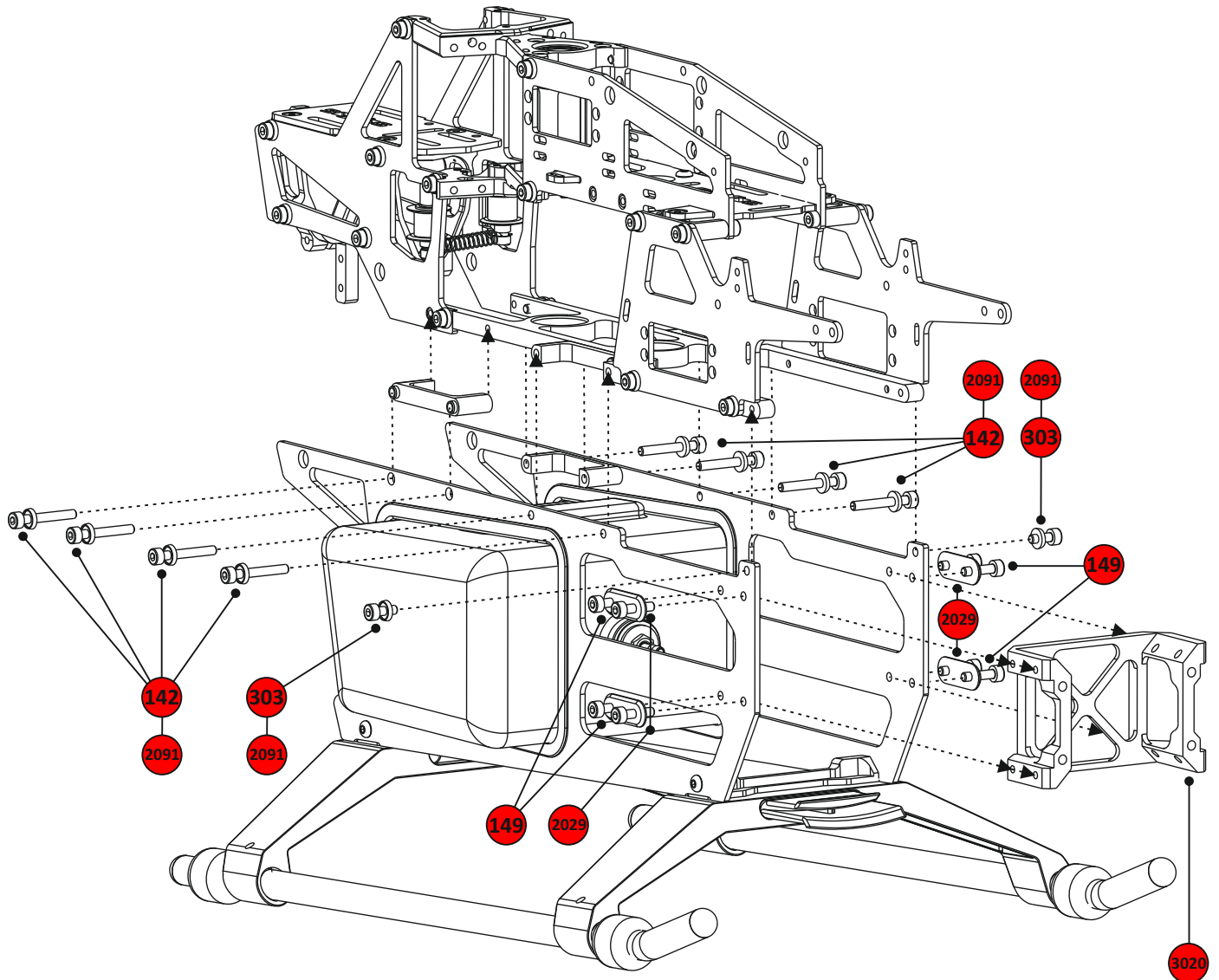

1:1

- 2029 Motorrahmenabstandhalter 4x Engine Frame Spacer

- 3019 Halter hinten Rail Back 2x

- 2091 U-Scheibe Washer 10x

- 3020 Motorbefestigung Engine Mount 1x





Normteile/Standard Parts

- 303** M3x8 Zylinderkopfschraube 4x
Socket Head Screw

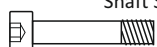

- 354** M3x8 Rundkopfschraube 9x
Round Head Screw

- 510** M3x16 Schaftschraube 1x
Shaft Screw

- 1639** M3x5 Senkschraube 3x
Countersunk Screw

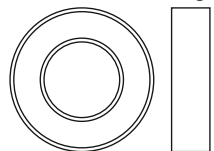

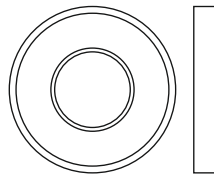
- 417** 10x19x5 Kugellager 4x
Ball Bearing



- 2075** 10x22x6 Kugellager 1x
Ball Bearing



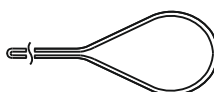

1:1

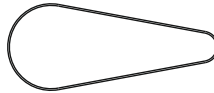
- 1743-06** Heckriemen 1x
Tail Drive Belt



- 2031** Hauptriemen 1x
Main Drive Belt



- 2032** Riemenrad 66Z 1x
Drive Bully 66T

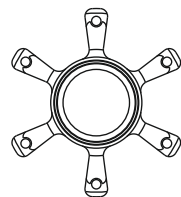

- 2070** Freilauf 10mm 1x
Oneway 10mm

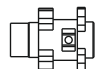

- 2076** Welle Zwischengetriebe 1x
Axe Intermediate Gear



- 2079** Autorotationsnabe 1x
Autorotation Hub



- 2089** Flanschmuffe 1x
Flanged Sleeve

- 2090** Zahnrad 29Z 1x
Drive Gear 29T

- 2091** U-Scheibe 4x
Washer

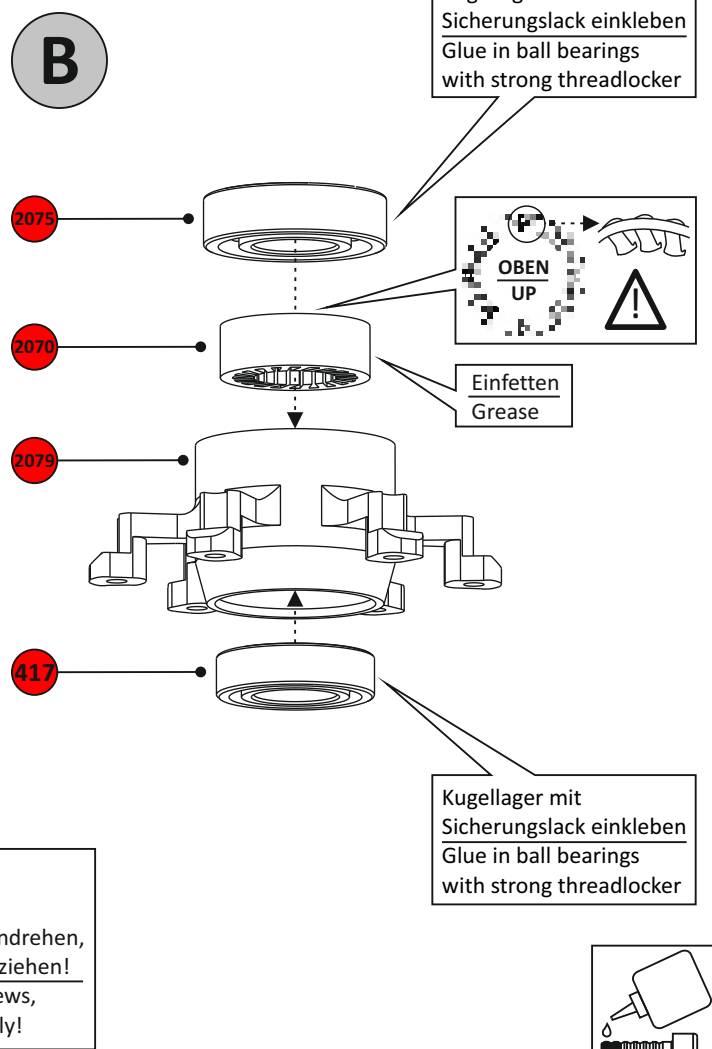
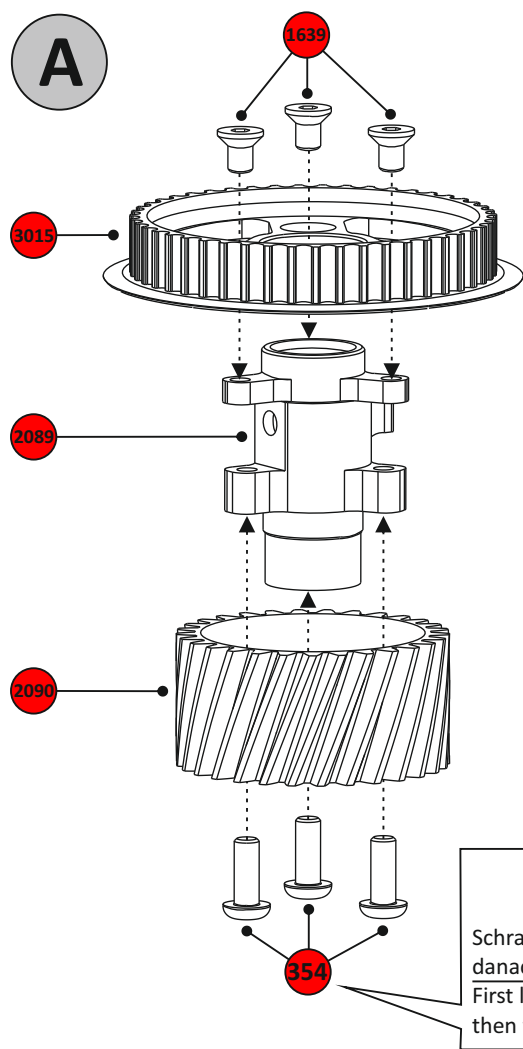

- 3015** Heckriemenrad 47Z 1x
Tail Drive Pulley 47T



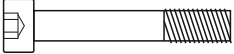

Normteile/Standard Parts

165 M4x24 Schaftschraube 1x
Shaft Screw



354 M3x8 Rundkopfschraube 12x
Round Head Screw



1:1

1643 Hauptzahnrad 81Z 1x
Main Drive Gear 81T



1594 10x16x0.1 Passscheiben 2x
Distance Washer

1595 10x16x0.2 Passscheiben 2x
Distance Washer



2082 Hauptzahnrad Nabe 1x
Drive Gear Hub

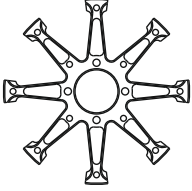

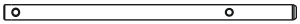

3059 Hauptrotorwelle 10mm 1x
Main Shaft 10mm

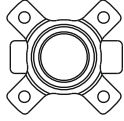
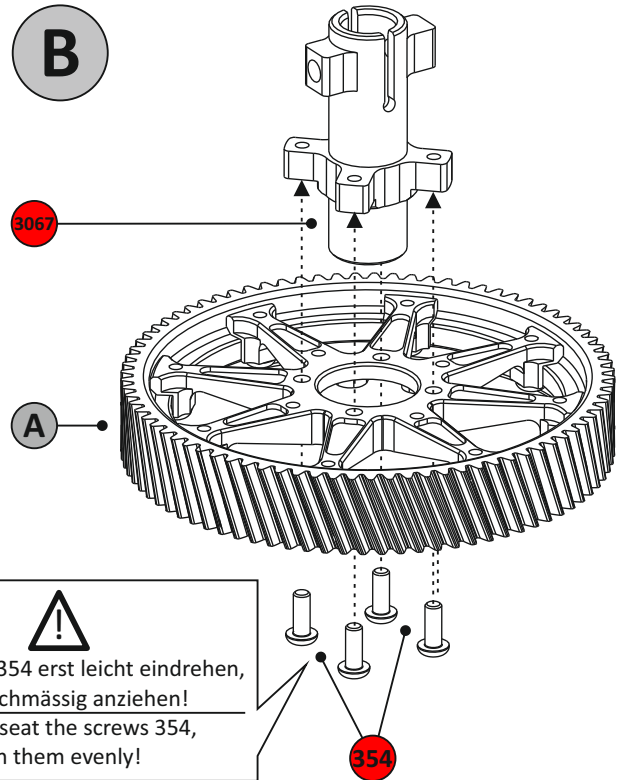
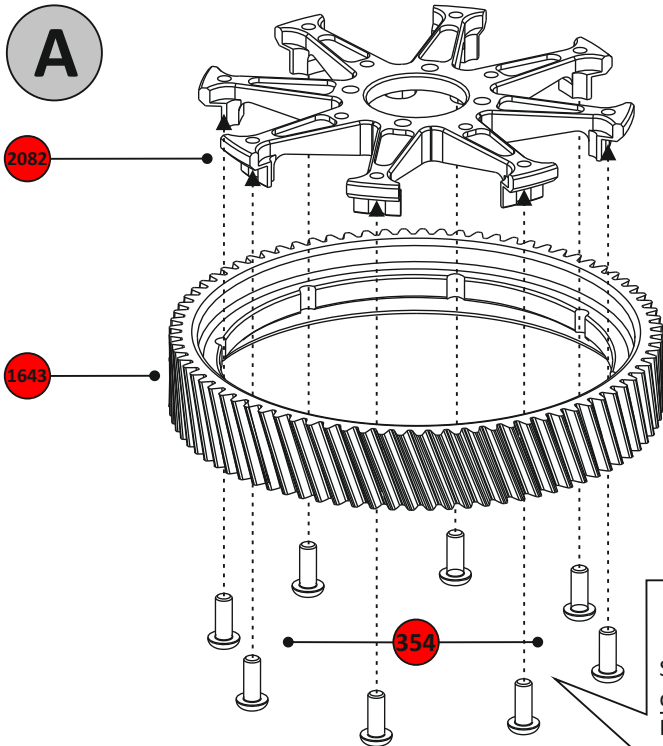

3067 Flanschhülse 1x
Flanged Sleeve

 Schrauben 354 erst leicht eindrehen, danach gleichmässig anziehen!
First lightly seat the screws 354, then tighten them evenly!

 Getriebeeinheit und Rotorwelle dürfen kein axiales Spiel im Rahmen haben. Benutzen Sie ggf. zur Justierung die beiliegenden Passscheiben.
There must be no axial movement of the transmission assembly when installed in the frame. Use the enclosed shim washers as required.



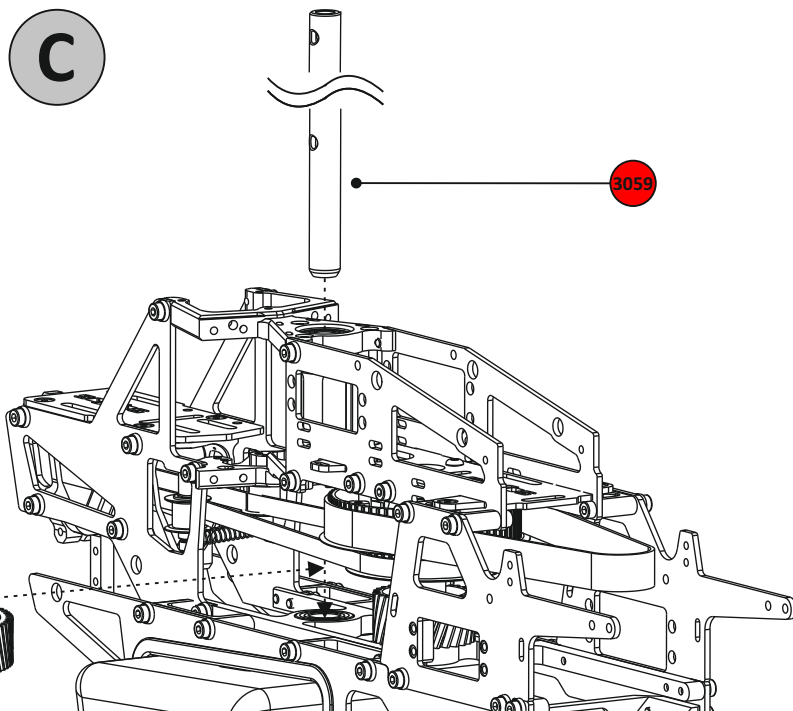





1594 **1595**

165



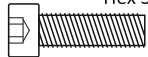

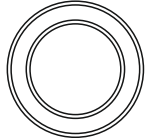
 Einfetten
Grease

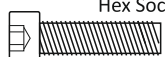

Normteile/Standard Parts

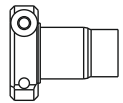
- 25 M2.5x8 Schraube Hex Socket Screw 8x

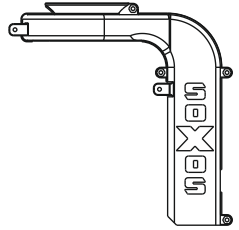
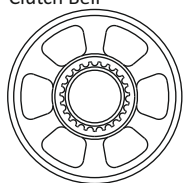
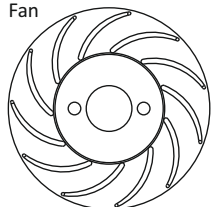
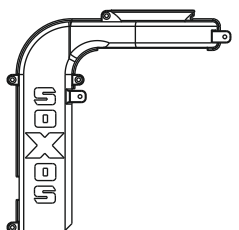
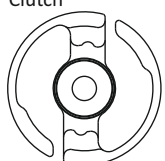
- 45 M2.5 Stopmutter Lock Nut 8x

- 53 M4x14 Schraube Hex Socket Screw 2x

- 71 M3x10 Zylinderkopfschraube 2x Socket Head Screw

- 297 12x18x4 Kugellager Ball Bearing 3x

- 2045 M4 Federscheibe Spring Washer 4x

- 3083 M4x16 Schraube Hex Socket Screw 4x

1:1

- 2022 Motorwelle Engine Shaft 1x

- 2025 Kupplungshalterung Clutch Support 1x

- 2038 Lüftergehäuse rechts Fan Case right 1x

- 2023 Kupplungsglocke Clutch Bell 1x

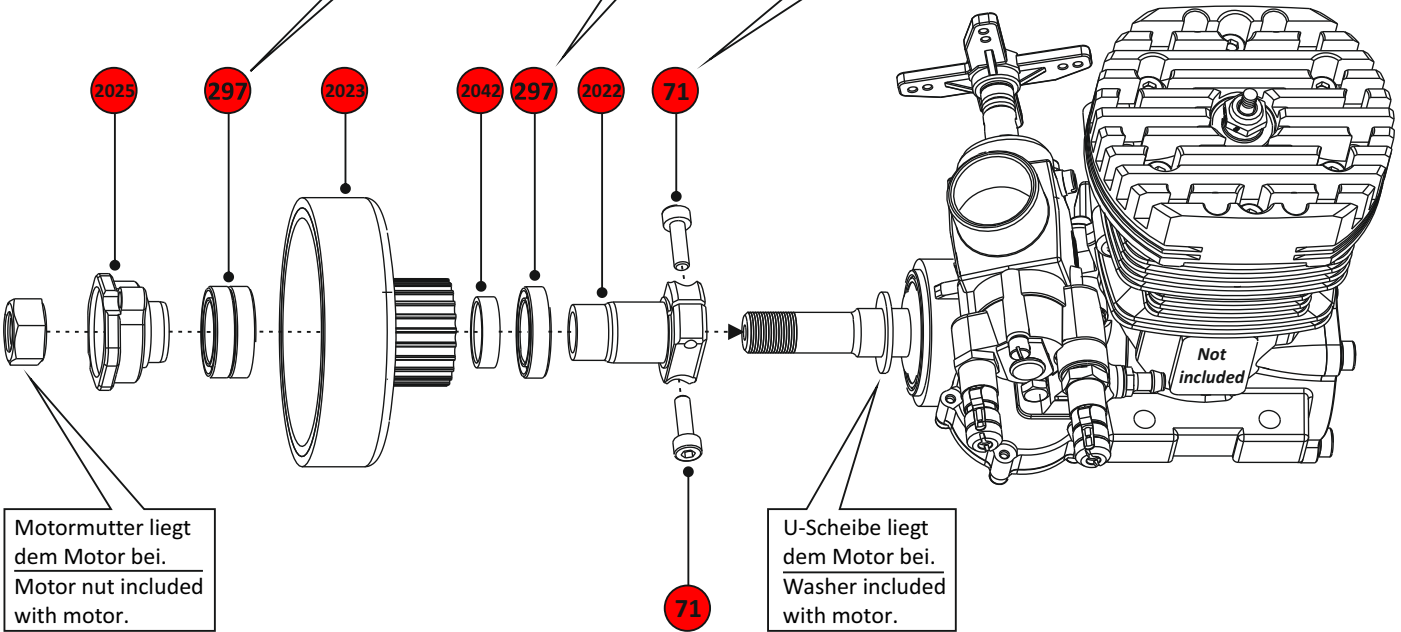
- 2027 Lüfter Fan 1x

- 2039 Lüftergehäuse links Fan Case left 1x

- 2024 Kupplung Clutch 1x

- 2042 Distanzhülse Distance Sleeve 1x

A

Kugellager 297 mit Sicherungslack einkleben
 Glue in ball bearings 297 with strong threadlocker

Erst wenn Motormutter festgezogen ist, Schrauben 71 anziehen!
 Only tighten the screws 71 once the motor nut has been tightened!



Motormutter liegt dem Motor bei.
 Motor nut included with motor.

U-Scheibe liegt dem Motor bei.
 Washer included with motor.



B

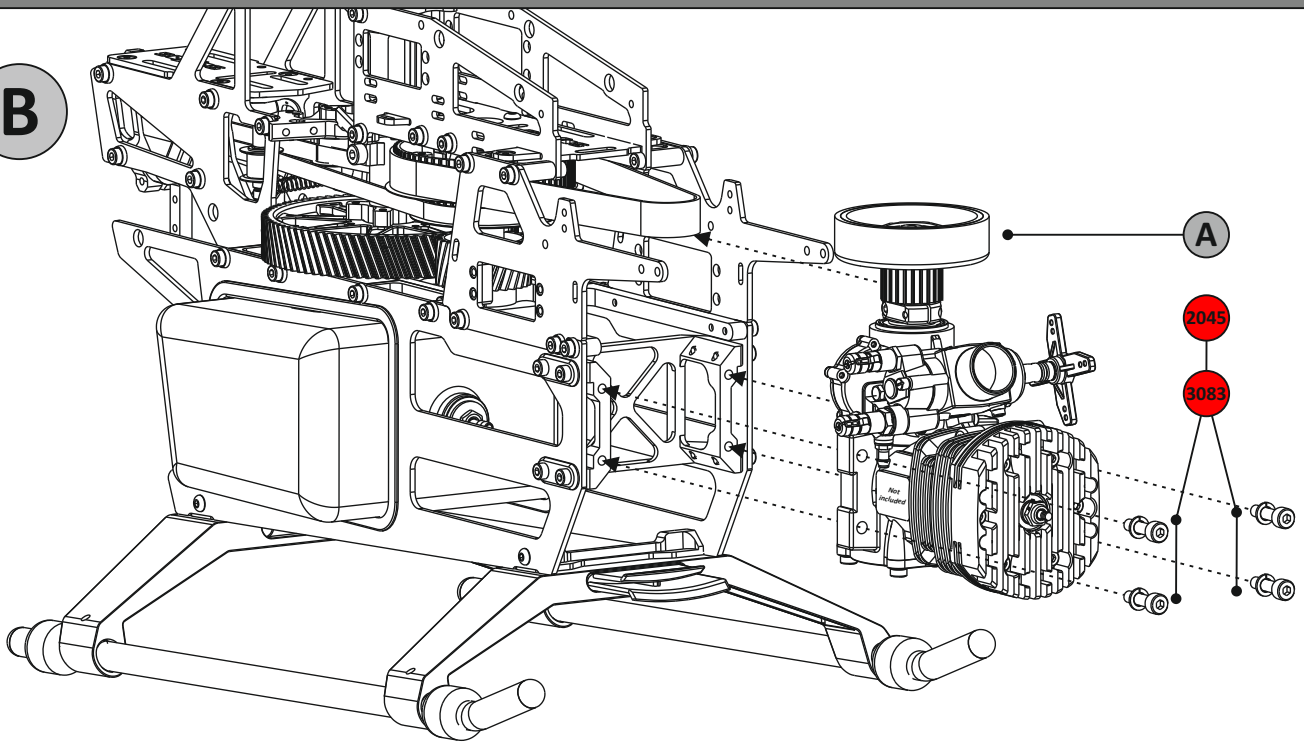

Beim anziehen der Schrauben 53, Lüferad 2027 mit Handschuh festhalten, um Verletzungen zu vermeiden!
 When tightening screws 53, secure the fan wheel 2027 with gloves to avoid injury!

C

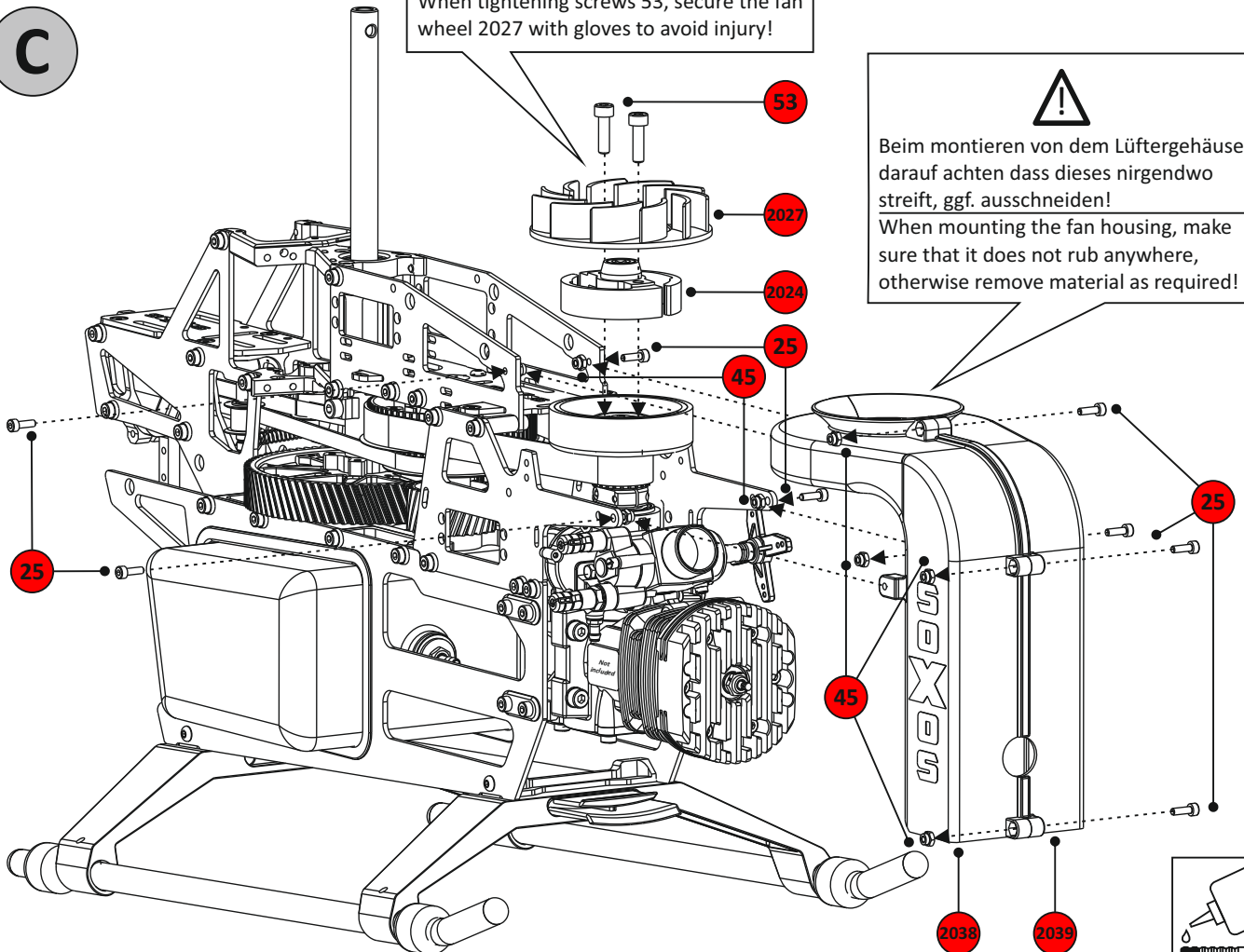

Beim montieren von dem Lüftergehäuse darauf achten dass dieses nirgendwo streift, ggf. ausschneiden!
 When mounting the fan housing, make sure that it does not rub anywhere, otherwise remove material as required!



Normteile/Standard Parts

11	M3	U-Scheibe Washer	20x
44	M2.5x5.5	Kugelbolzen Ball-End Bolt	1x
45	M2.5	Stopmutter Lock Nut	1x
145	M3x4.5	Kugelpfopf Ball End Screw	5x
354	M3x8	Rundkopfschraube Round Head Screw	5x
1600	M3x12	Rundkopfschraube Round Head Screw	20x

1:1

41	Servoplättchen Servo Mounting Plates	10x	3047	Heckservoarm Tail Servo Horn	1x
1797	Servoarm Servo Horn	4x	3076	Servohalter 20mm Servo Holder 20mm	4x
1659 1663	Servo Einsatz 23Z,24Z,25Z,25Z/8 Insert Servo 23T,24T,25T,25T/8		3081	Servohalter 15mm Servo Holder 15mm	2x

A

Den passenden Einsatz zum Servo verwenden.
Use the correct insert for the servo.

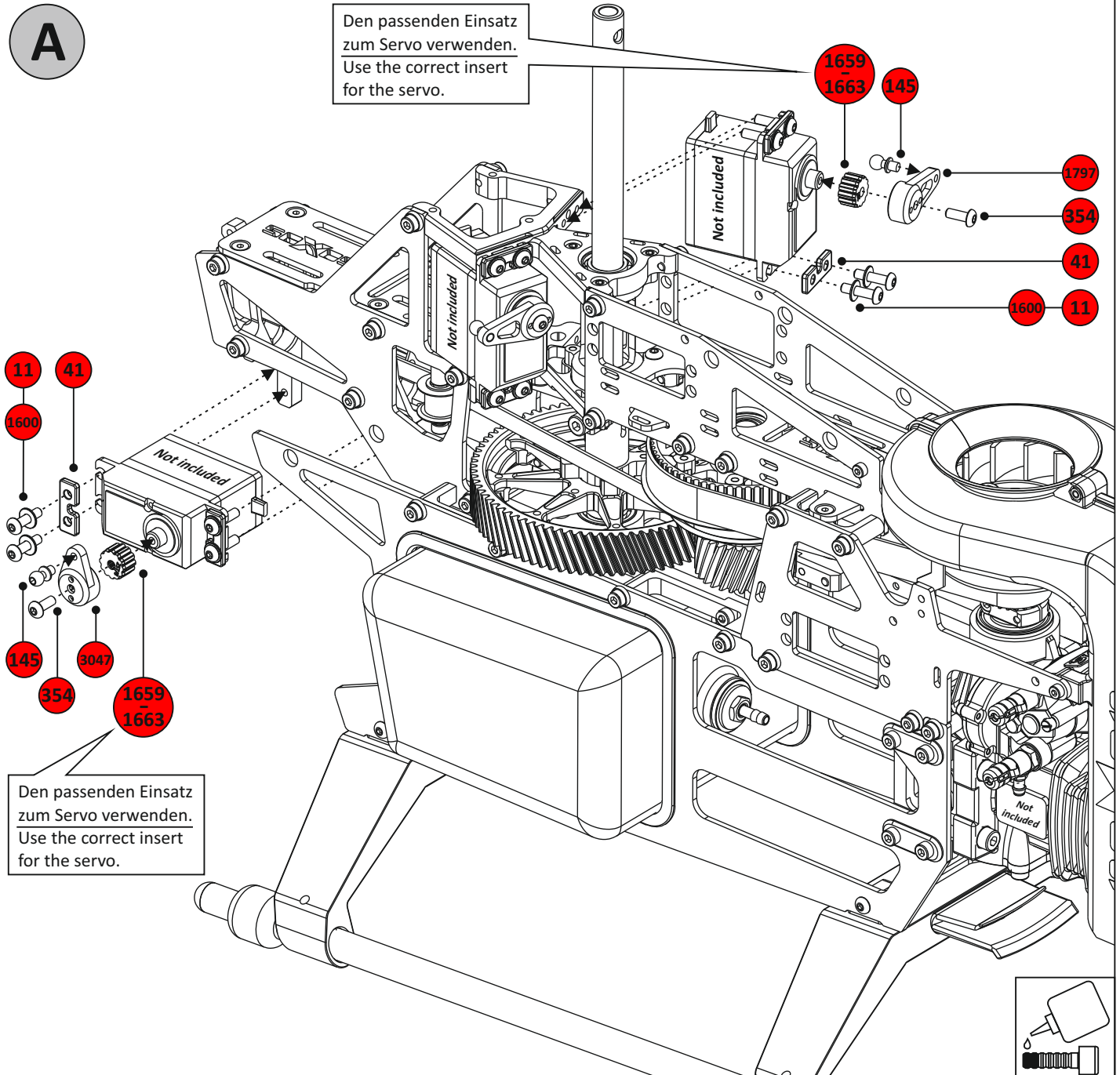

Den passenden Einsatz zum Servo verwenden.
Use the correct insert for the servo.



Normteile/Standard Parts

- 145** M3x4.5 Kugelpfanne Ball End Screw 4x
- 155** M3x6 Rundkopfschraube Round Head Screw 4x
- 309** M3x7 Kugelpfanne Ball End Screw 2x
- 549** M3x7 Kugelpfanne lang Ball End Screw long 1x

- 359** Kugelpfanne Ball Link 6x
- 1790** Taumelscheibe Swashplate 1x

- 2084** Taumelscheibenführungs-Halter Swashplate Guide Holder 1x
- 2085** Taumelscheibenführung Swashplate Guide 1x

- 3023** Schubstange Control Rod 3x
- 3089** Gummifixierung Fixing Rubber 1x

1:1

 Schrauben Sie die Kugelpfannen 359 so weit wie möglich auf der Schubstange 3023 zusammen.
Screw ball links 359 together as far as possible on the control rod 3023!

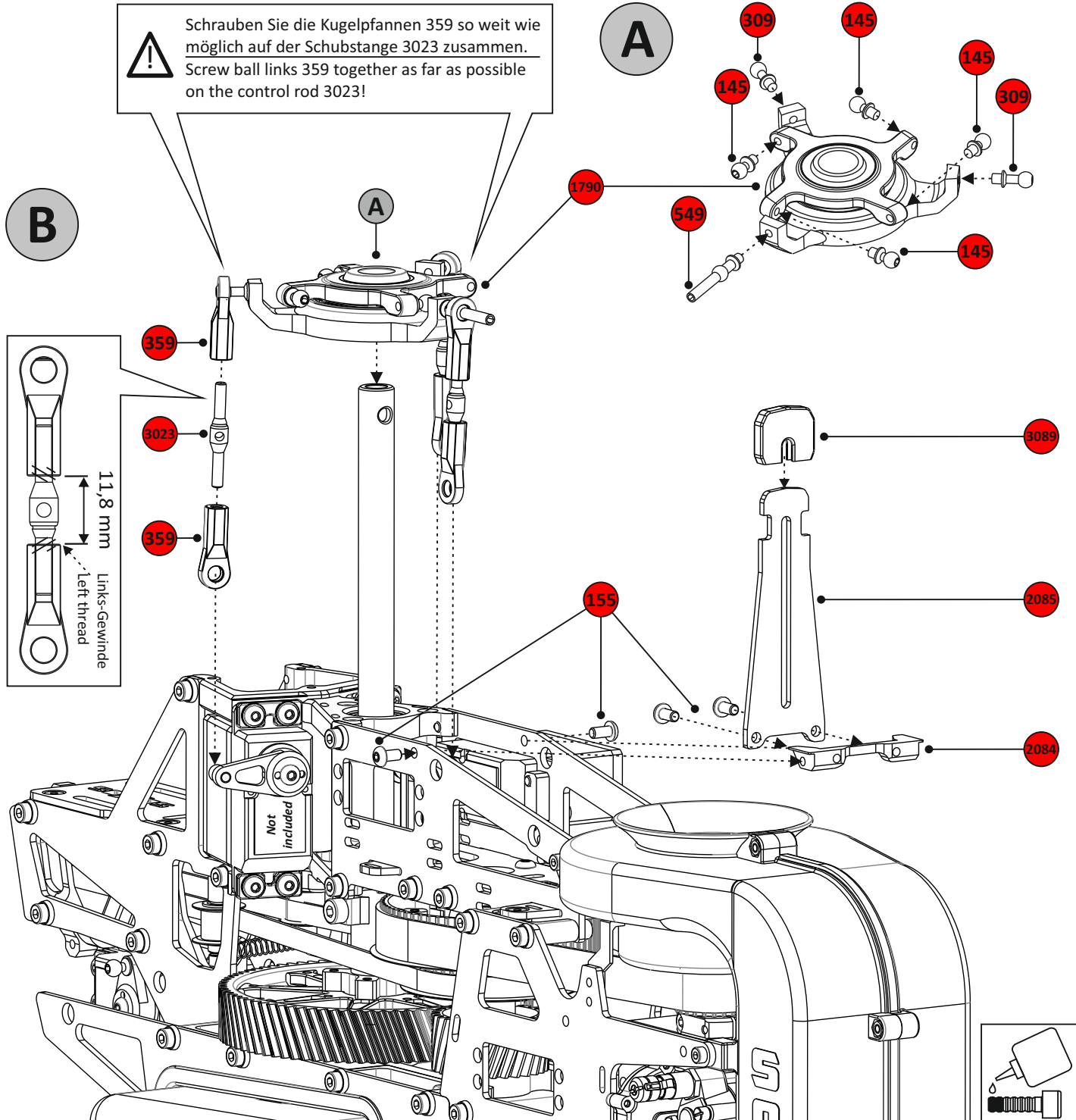

Normteile/Standard Parts

47	8x11.6x0.5 Distanzscheibe Shim Washer	2x	21	M3x6 Schraube Hex Socket Screw	4x
48	8x14x4 Kugellager Ball Bearing	2x	145	M3x4.5 Kugelfopf Ball End Screw	2x
1705	3x8x3 Flanschlager Flanged Bearing	8x	481	M6x14 Rundkopfschraube Round Head Screw	2x
3042	3x7.5x2.5 Adapterhülse Shim Sleeve	4x	1600	M3x12 Rundkopfschraube Round Head Screw	2x
2000	8x16x5 Kugellager Ball Bearing	2x	1602	M3x12 Gewindestift Set Screw	2x

1:1

349	8x16x5 Drucklager Thrust Bearing	2x			
	large ID (IN)			small ID (OUT)	
3088	Dämpferhülse Damper Sleeve	2x	1813-70	Dämpfer 70° Damper 70°	6x
478	Blattlagerwelle Spindle Shaft	1x			
369c	Mischhebelarm Mixing Lever Arm	2x	1985	Blattlagerwellenführung Spindle Shaft Support	1x
3036	Mitnehmer Arm Mixing Lever	2x	359	Kugelfopf Ball Link	2x
3070	Zentralstück Main Hub Nitro	1x	1982-1	Blatthalter Blade Holder Nitro	2x
			3072	Kugelfannhalter Ball Link Holder	2x

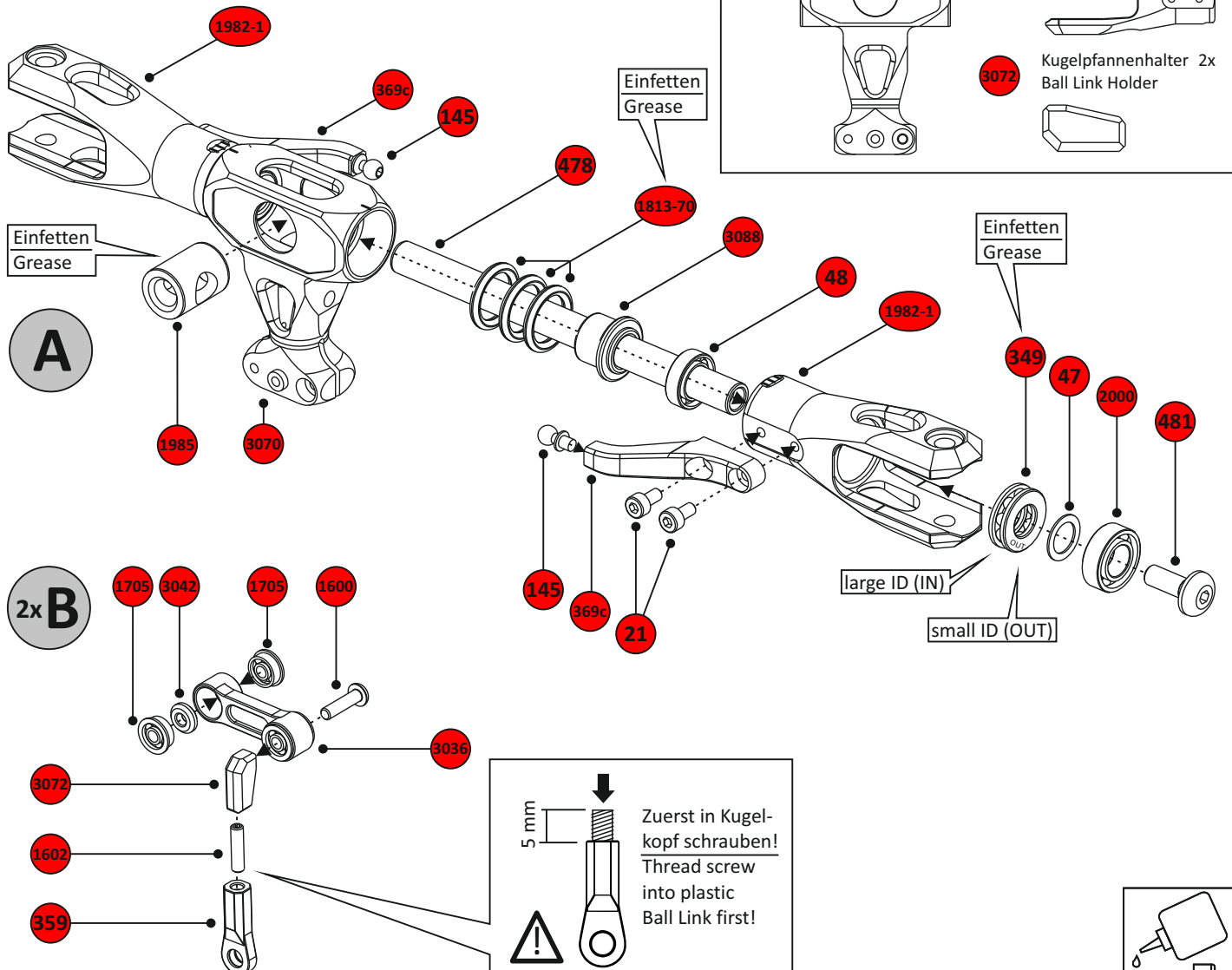

Normteile/Standard Parts

50	M4	Stopmutter Lock Nut	1x
71	M3x10	Zylinderkopfschraube Socket Head Screw	2x
165	M4x24	Schaftschraube Shaft Screw	1x
1600	M3x12	Rundkopfschraube Round Head Screw	2x

1:1

359	Kugelpfopf Ball Link	6x	1809-1	Schubstange Control Rod	2x	3025	Schubstange- Drosselklappe Control Rod Throttle	1x
------------	-------------------------	----	---------------	----------------------------	----	-------------	---	----

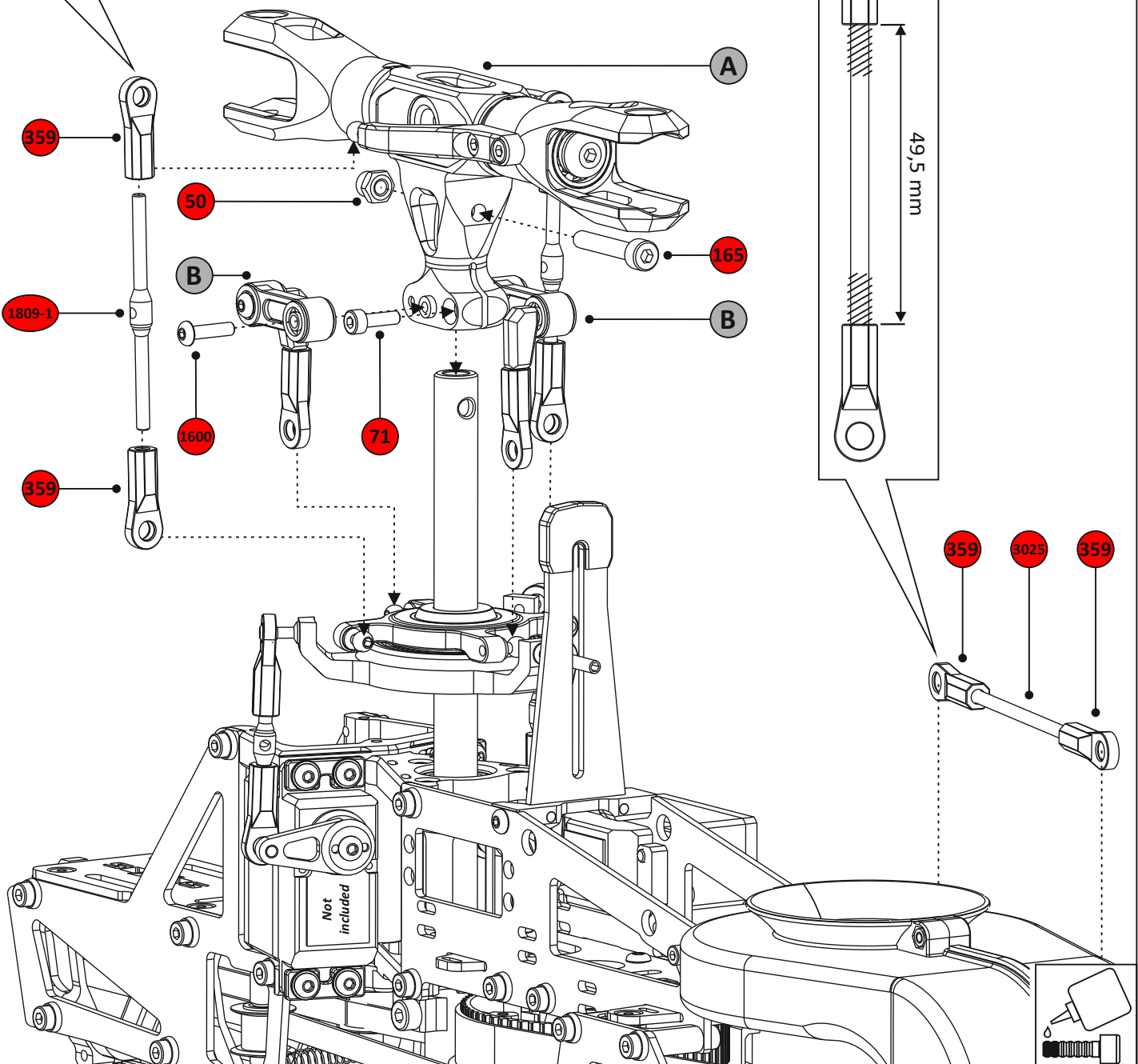
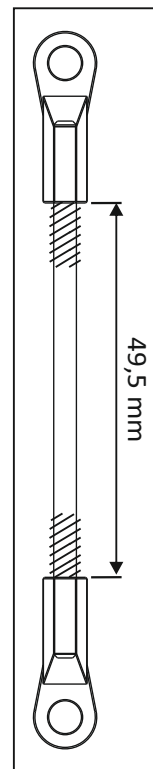
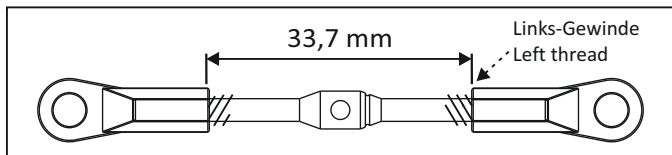
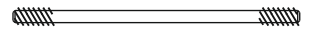
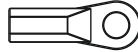

Normteile/Standard Parts

8	3x12	Treibschraube Self Tapping Screw	1x	1684	M3x10 Rundkopfschraube Round Head Screw	2x
54	3x7x3	Flanschlager Flanged Bearing	2x	1695	2.5x15 Stift 2.5x15mm Pin	2x
303	M3x8	Zylinderkopfschraube Socket Head Screw	1x	1804	Druckfeder Pressure Spring	2x
1639	M3x5	Senkschraube Countersunk Screw	3x	2091	U-Scheibe Washer	1x

2087	Empfängerplatte Receiver Plate	1x	3097	Sicherheitshebel Safety Lever	1x
3075	Haubenhalter Canopy Holder	1x	3098	Federhülse rechts Spring Sleeve right	1x
			3099	Federhülse links Spring Sleeve left	1x

1:1

A

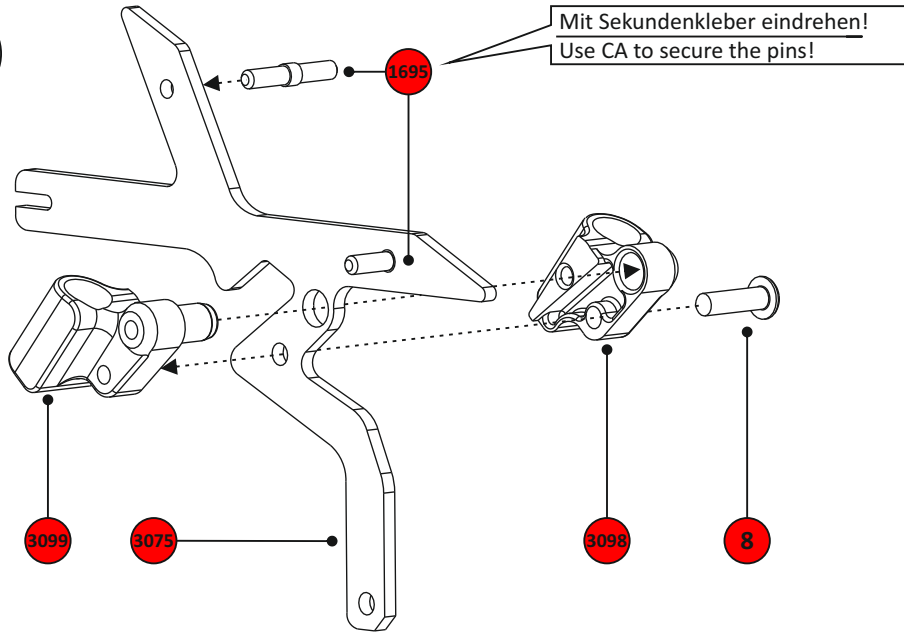

B

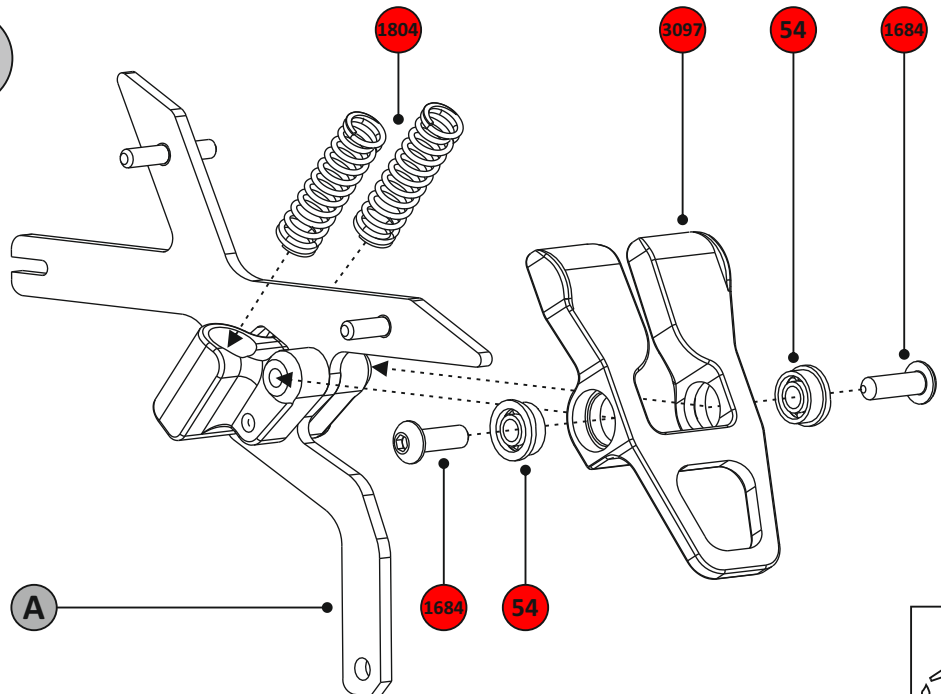

13

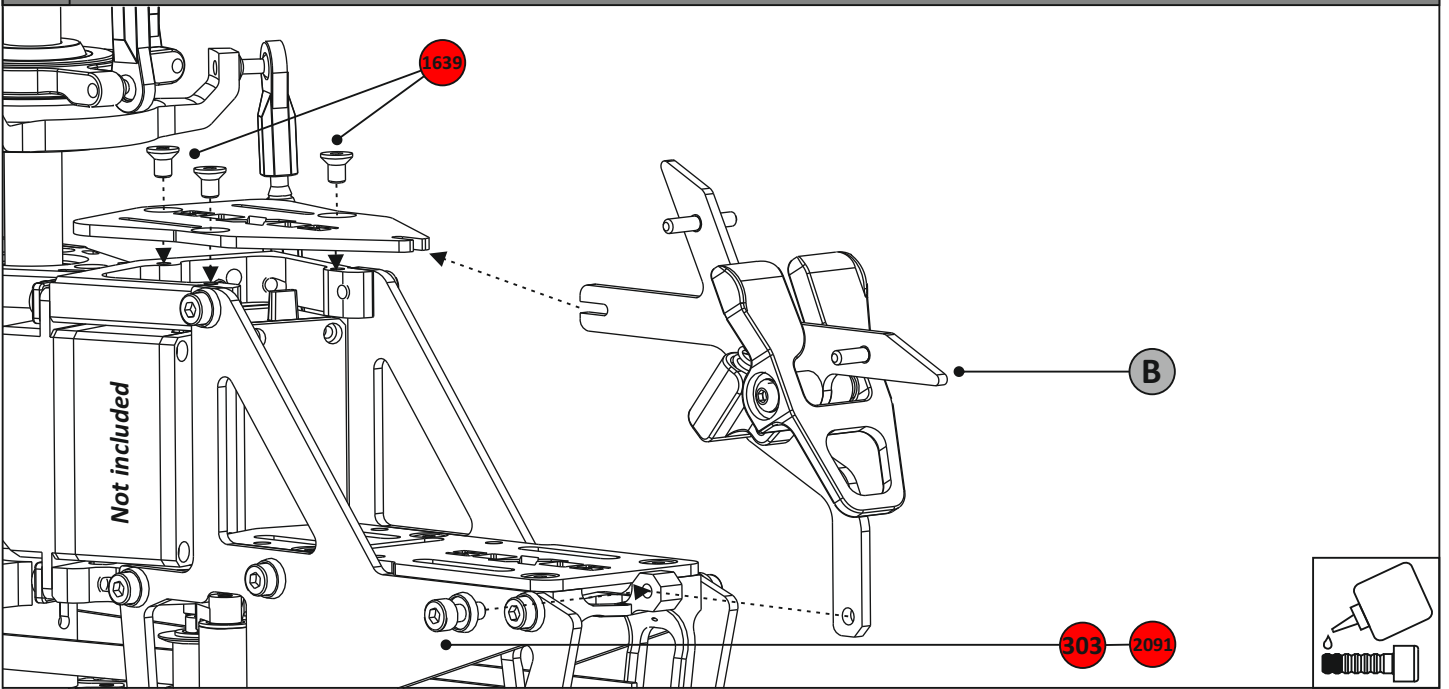

14

1764

Heckrohr 700
Tail Boom 700

1x

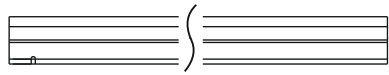





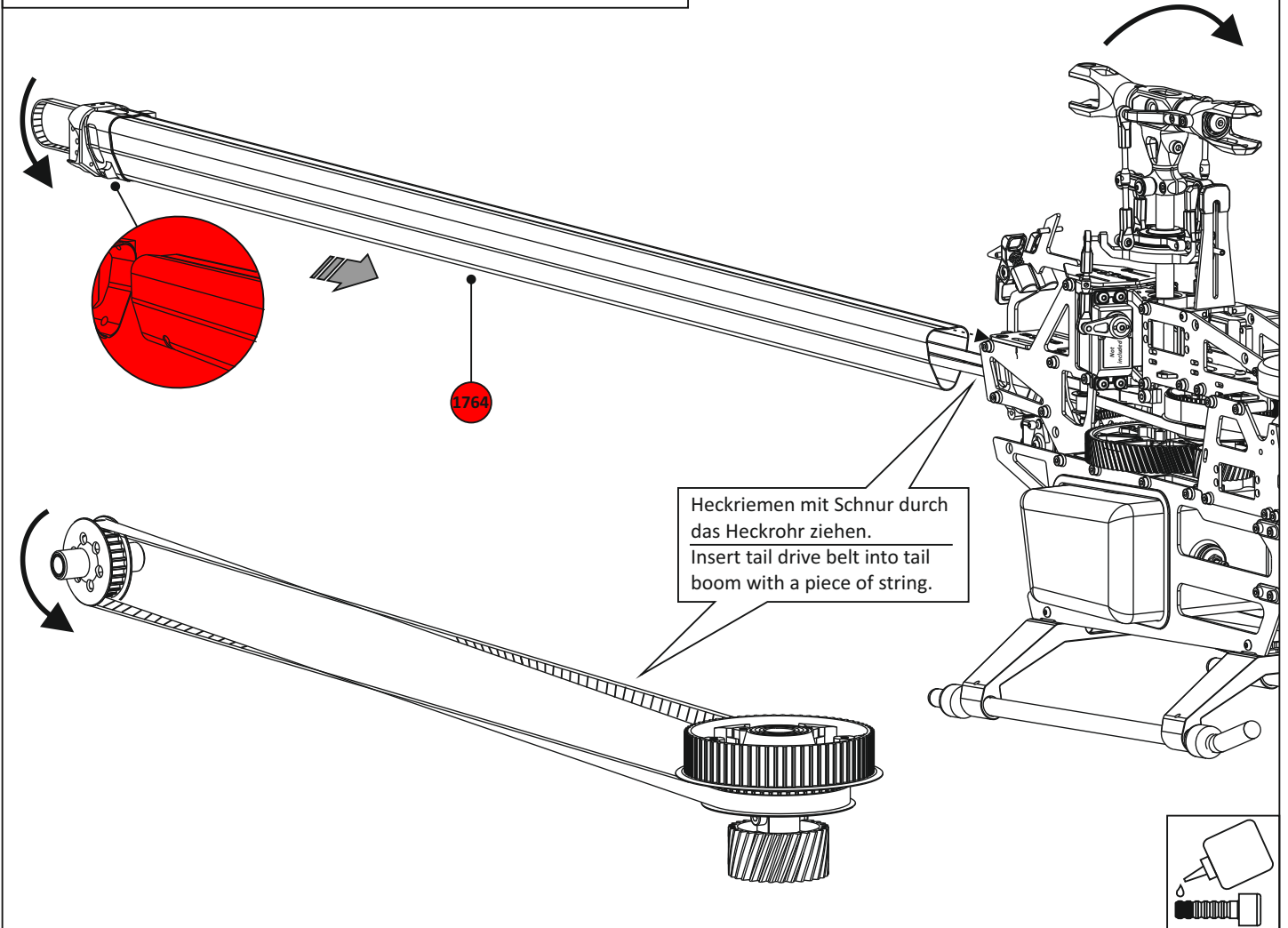
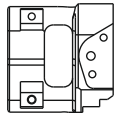

1765

Heckrotorgehäuse
Tail Rotor Housing



1x



Normteile/Standard Parts

- 145 M3x4.5 Kugelpopf Ball End Screw 1x

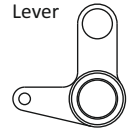
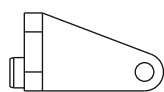
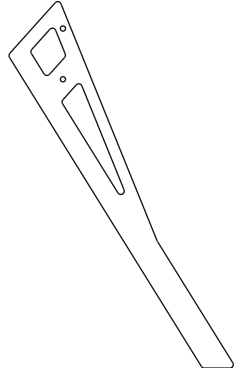
- 155 M3x6 Rundkopfschraube Round Head Screw 2x

- 354 M3x8 Rundkopfschraube Round Head Screw 1x

- 1600 M3x12 Rundkopfschraube Round Head Screw 1x

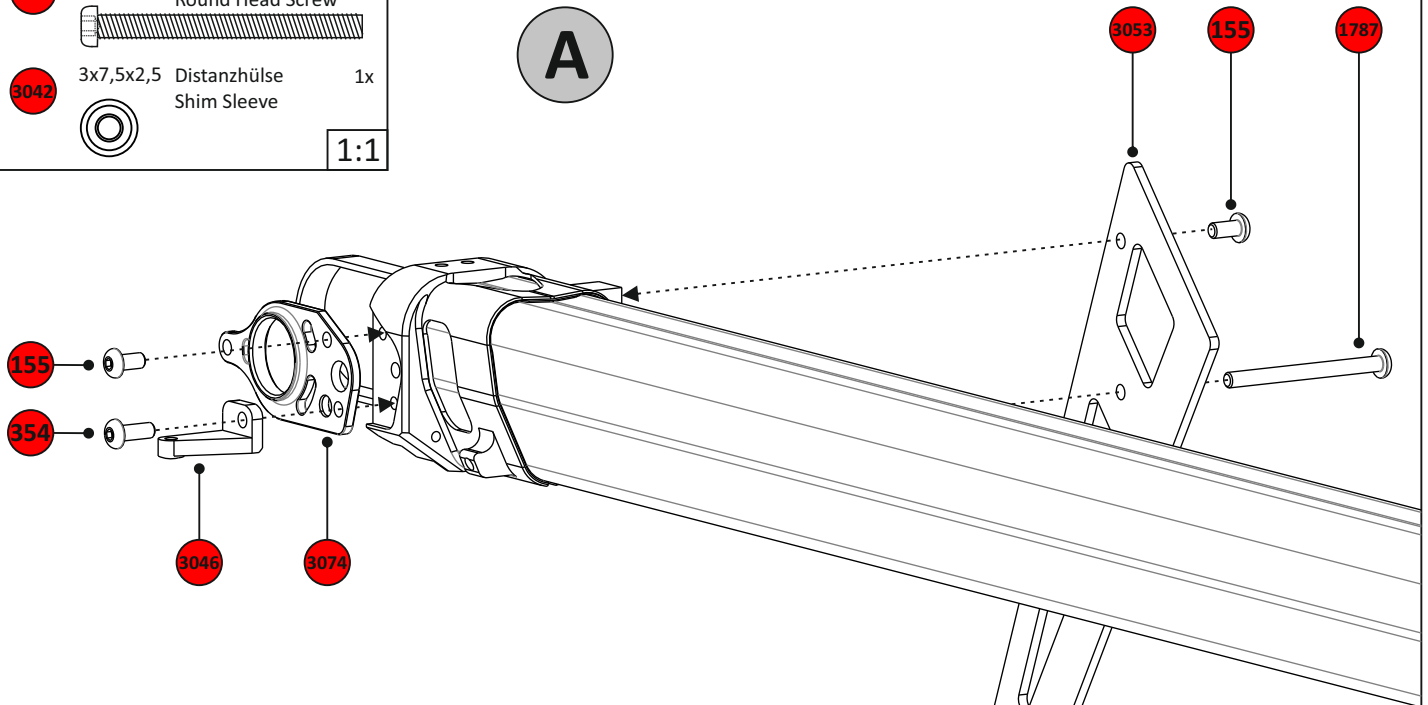
- 1705 3x8x3 Flanschlager Flanged Bearing 2x

- 1787 M3x35 Rundkopfschraube Round Head Screw 1x

- 3042 3x7,5x2,5 Distanzhülse Shim Sleeve 1x

1:1

- 3044 Steuerhebel Lever 1x

- 3046 Halterung Bracket 1x

- 3053 Carbon Seitenleitwerk Carbon Vertical Fin 1x

- 3045 Einlage Insert 1x

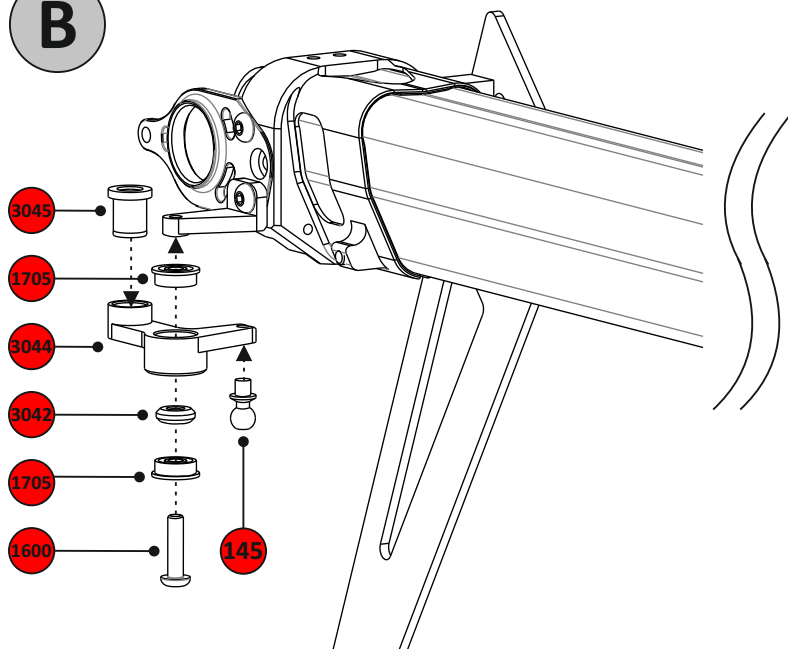
- 3074 Seitenplatte Heckgehäuse rechts Tail Rotor Housing Side Plate right 1x

A



B



Normteile/Standard Parts

- | | |
|--|--|
| 145 M3x4.5 Kugelbolzen 3x
Ball-End Screw | 69 7.5x9.9x0.4 Passscheibe 2x
Shim Washer |
| 444 5x1 O-Ring 2x | 443 5.2x7.5x0.7 Passscheibe 2x
Shim Washer |
| 68 5x10x4 Kugellager 2x
Ball Bearing | 503 M2x5.5 Zylinderkopfschraube 2x
Socket Head Screw |
| 74g 6x10x3 Kugellager 2x
Ball Bearing | 303 M3x8 Zylinderkopfschraube 2x
Socket Head Screw |

- | | |
|---|---|
| 1711-1 Heckrotornabe 1x
Tail Rotor Hub | 1704 Blatthalter Heckrotor 2x
Blade Holder Tail Rotor |
| 151 5x10x4 Drucklager 2x
Thrust Bearing | 3051 Hecksteuerbrücke 1x
Tail Pitch Control |
| 70 3x7.5x1 Unterlegscheibe 2x
Washer | 268 Hecksteuerbrückenarme 2x
Tail Pitch Control Arms |

1:1

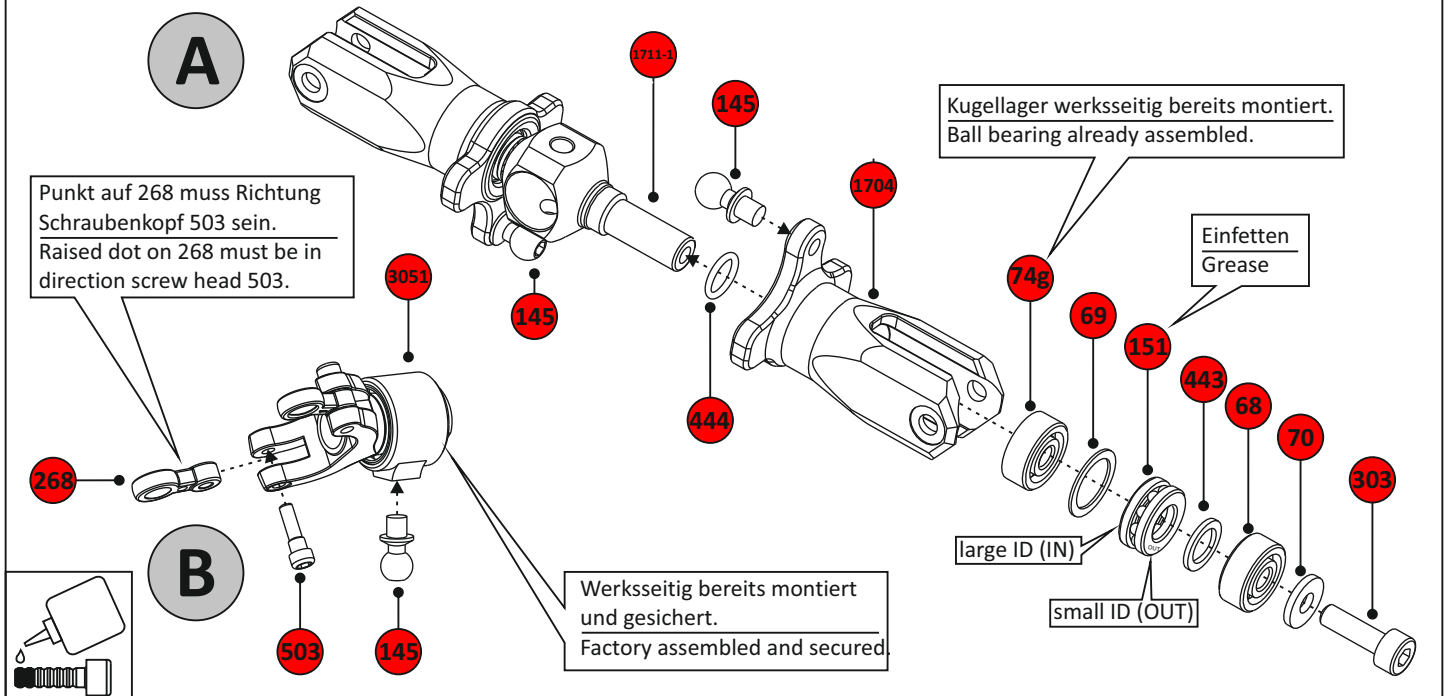

Normteile/Standard Parts

- | | |
|---|---|
| 33 M4x4 Gewindestift 1x
Set Screw | 1714 Dämpfergummi 4x
Damper Rubber |
| 1715 3x13 Bolzen 1x
Bolt | 3027 Heckrotorwelle 1x
Tail Rotor Shaft |

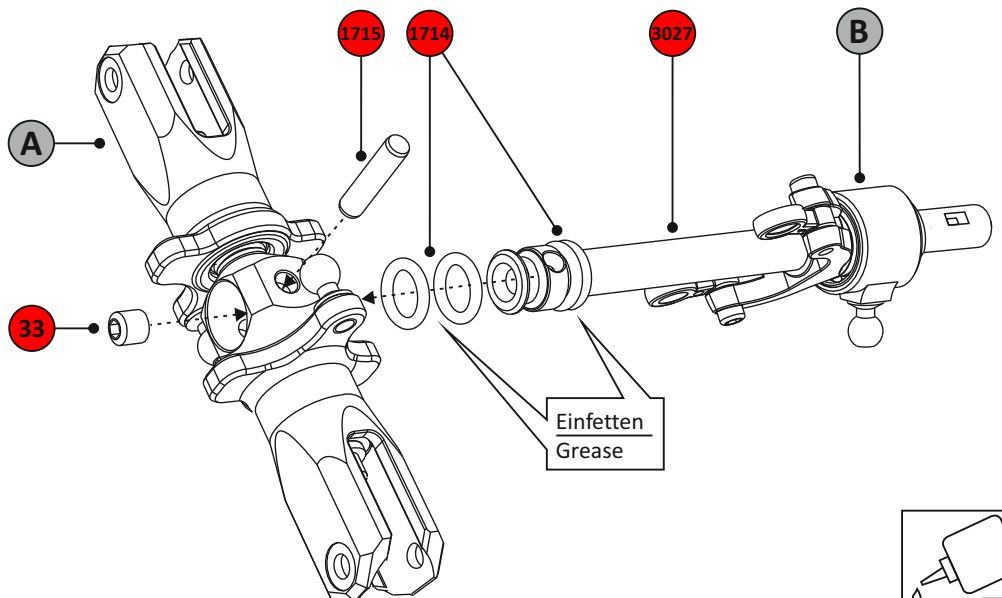

1:1

Normteile/Standard Parts

- | | | | | | | |
|-------------|-------|---|----|-------------|--|----|
| 155 | M3x6 | Rundkopfschraube 6x
Round Head Screw | 6x | 3073 | 6x15x5 Flanschlager
Flanged Bearing | 2x |
| 1600 | M3x12 | Rundkopfschraube 1x
Round Head Screw | 1x | 1802 | 3x8x3 Kugellager
Ball Bearing | 2x |
| 2098 | M4x4 | Gewindestift spitz
Set Screw sharp | 1x | | | |
| 3038 | M4x3 | Gewindestift
Set Screw | 1x | | | |

- | | | | | | |
|-------------|--|----|-------------|---|----|
| 3029 | Heckantriebsrolle 26Z
Tail Drive Pulley 26T | 1x | 1772 | Kugellagerhalter
Bearing Stand | 1x |
| 1770 | Distanz Heckgehäuse
Spacer Tail Rotor Housing | 1x | 3026 | Seitenplatte Heckgehäuse
Tail Rotor Housing Side Plate | 1x |

1:1

A

Heckantriebsrolle in Heckriemen einsetzen.
Insert tail drive pulley into tail drive belt.

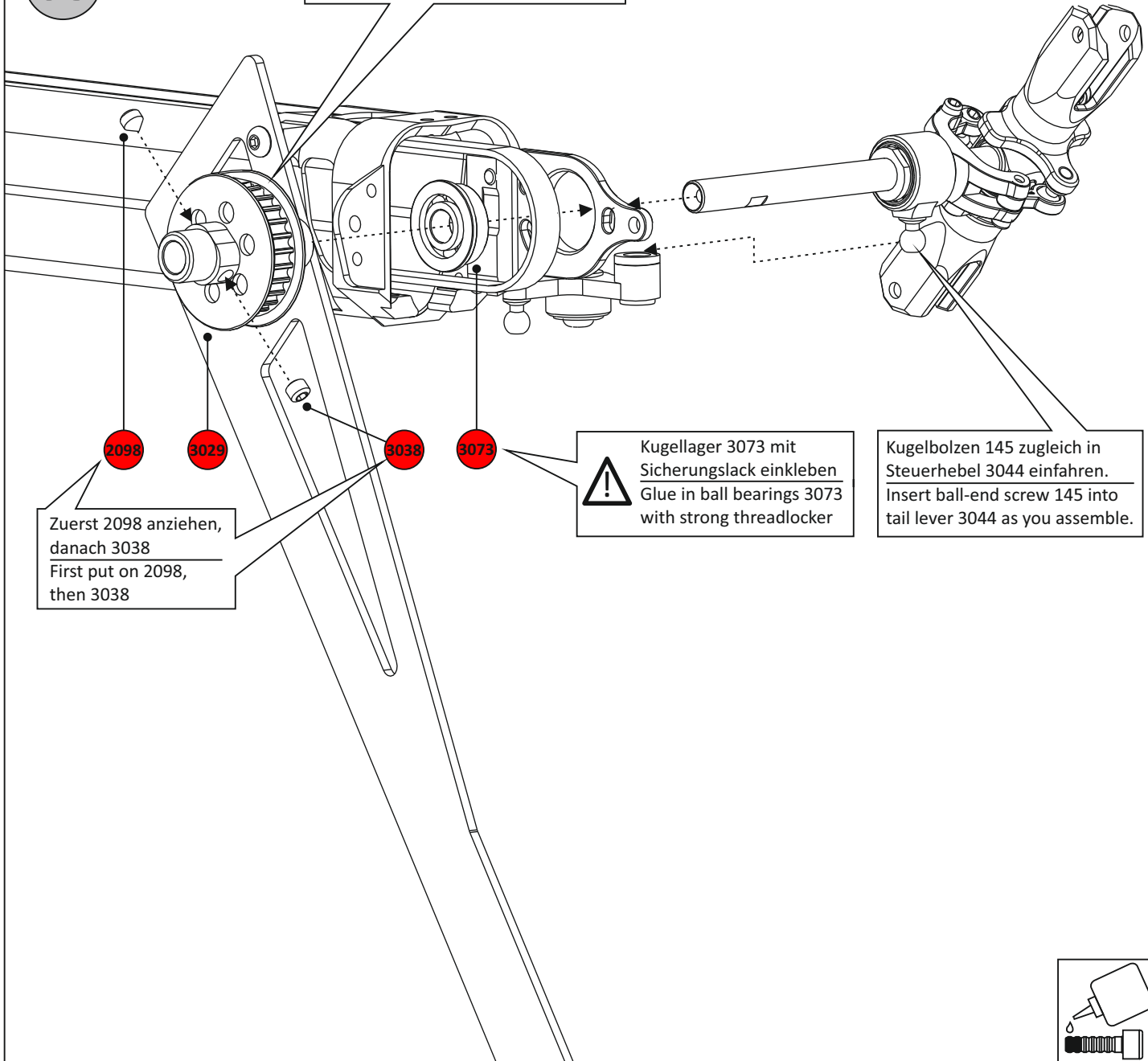

Zuerst 2098 anziehen,
danach 3038
First put on 2098,
then 3038

! Kugellager 3073 mit
Sicherungslack einkleben
Glue in ball bearings 3073
with strong threadlocker

Kugelbolzen 145 zugleich in
Steuerhebel 3044 einfahren.
Insert ball-end screw 145 into
tail lever 3044 as you assemble.

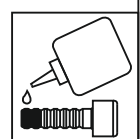

B

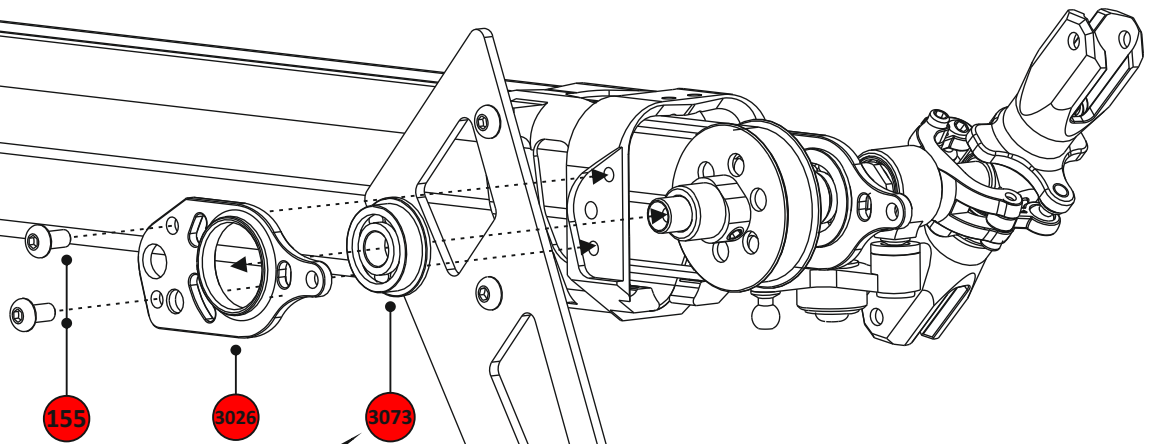

Kugellager 3073 mit
Sicherungslack einkleben
Glue in ball bearings 3073
with strong threadlocker

C

Seitlich ausrichten damit Riemenrad
nicht am Kugellager 1802 streift.
Adjust sideways position so that the
drive pulley flange does not brush
against ball bearing 1802.

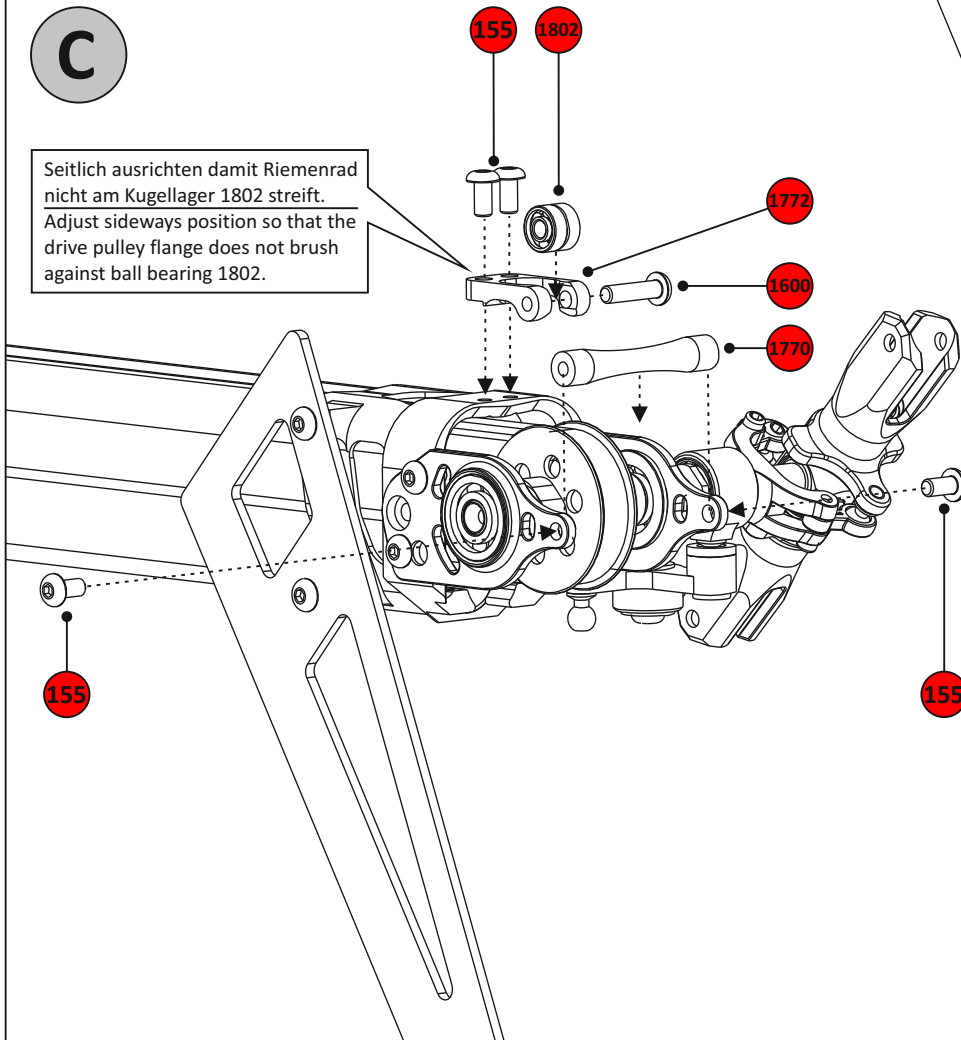

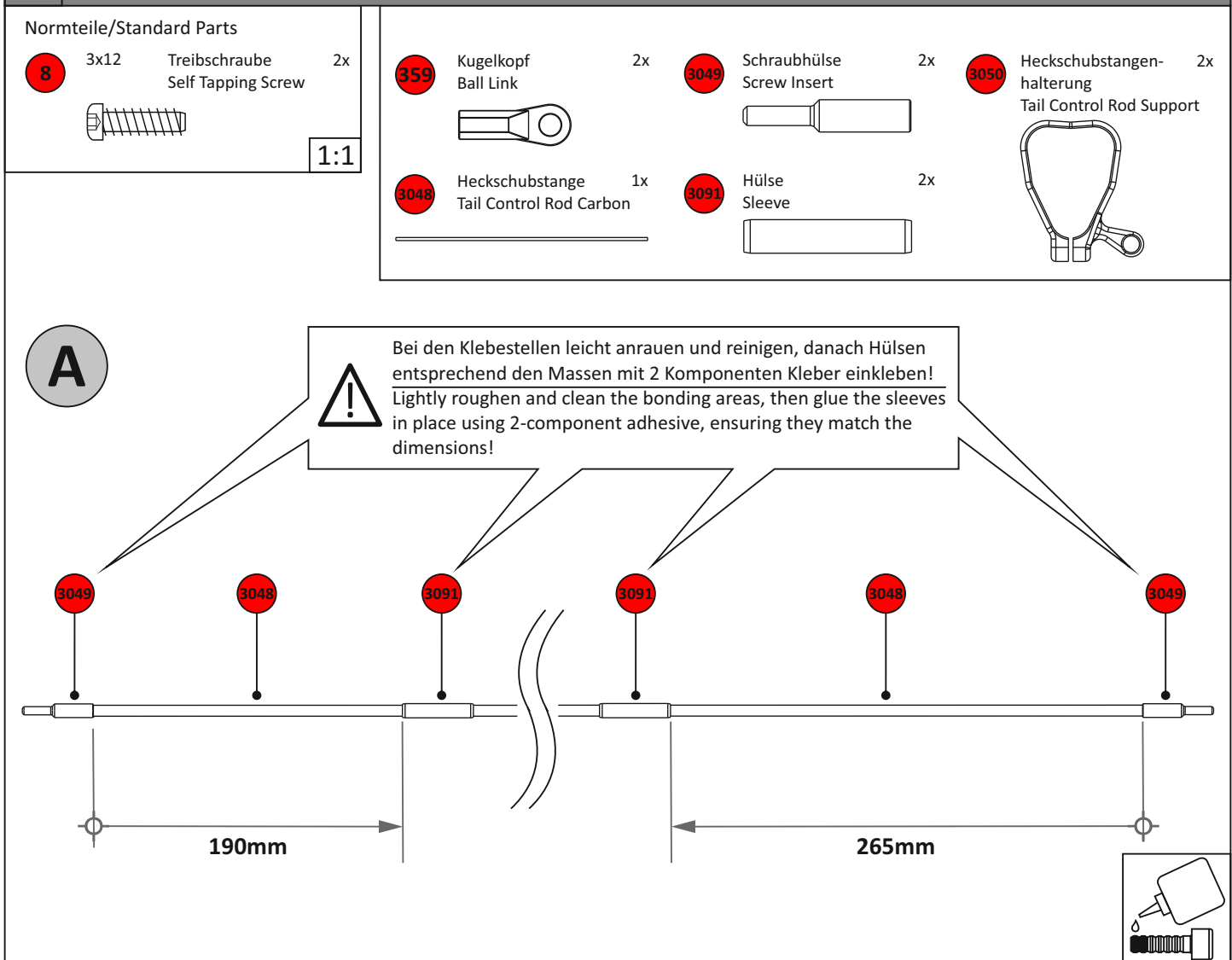
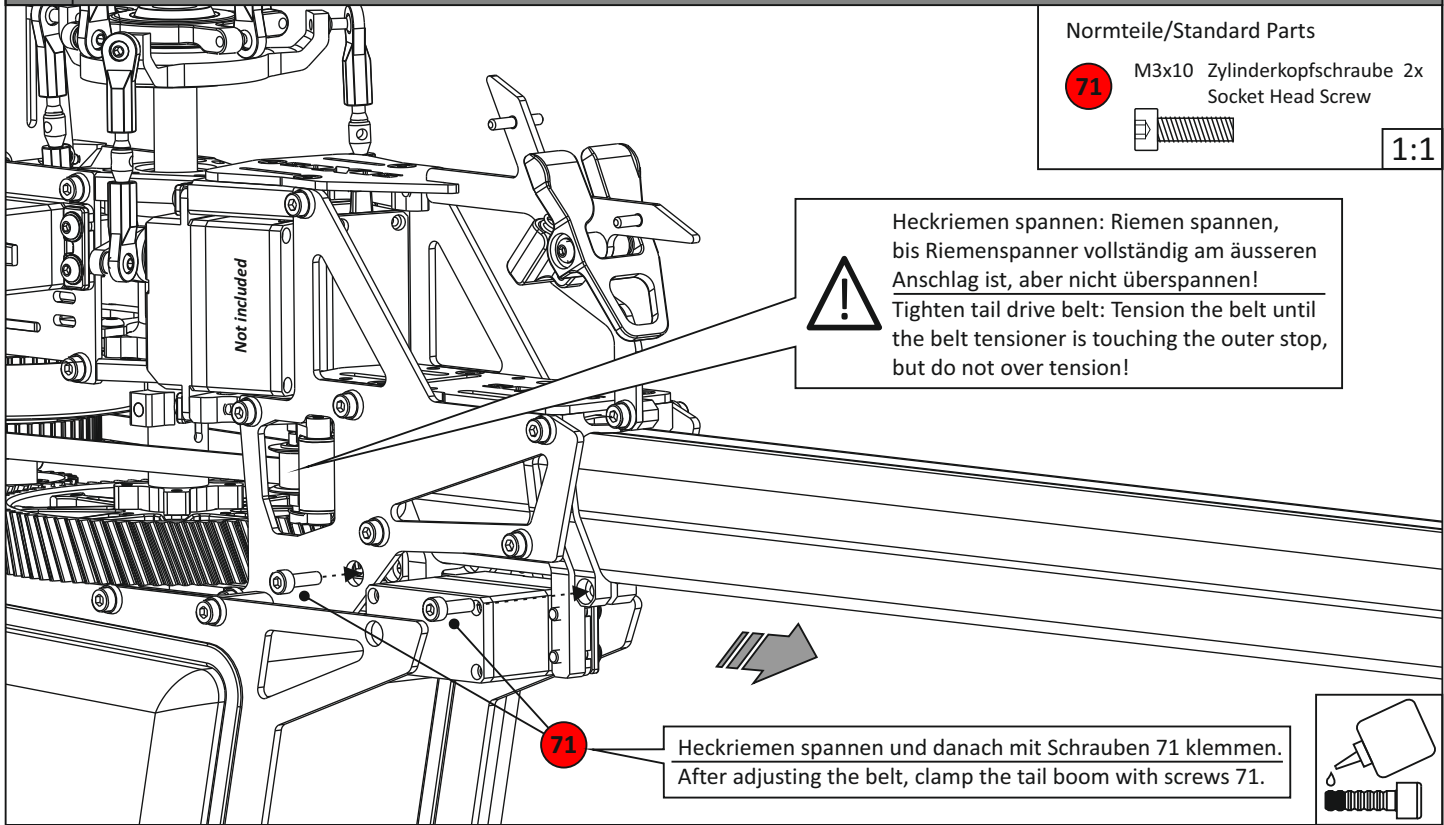

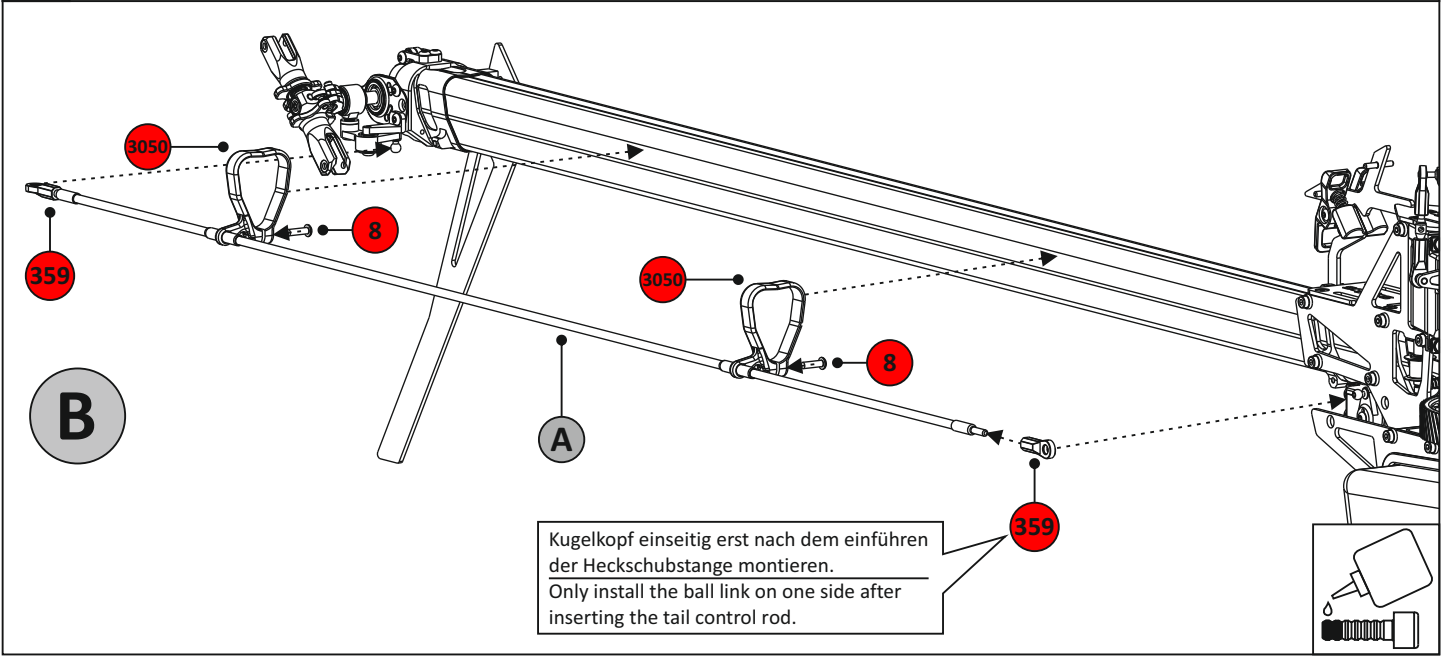

Normteile/Standard Parts

1639	M3x5	Senkschraube Countersunk Screw	2x
			1:1

3103	Akkuplatte Battery Plate	1x	3105	Gummibuchse Rubber Bushing	2x
3104	Bolzen Bolt	2x	3106	Federstecker R-Clip	2x

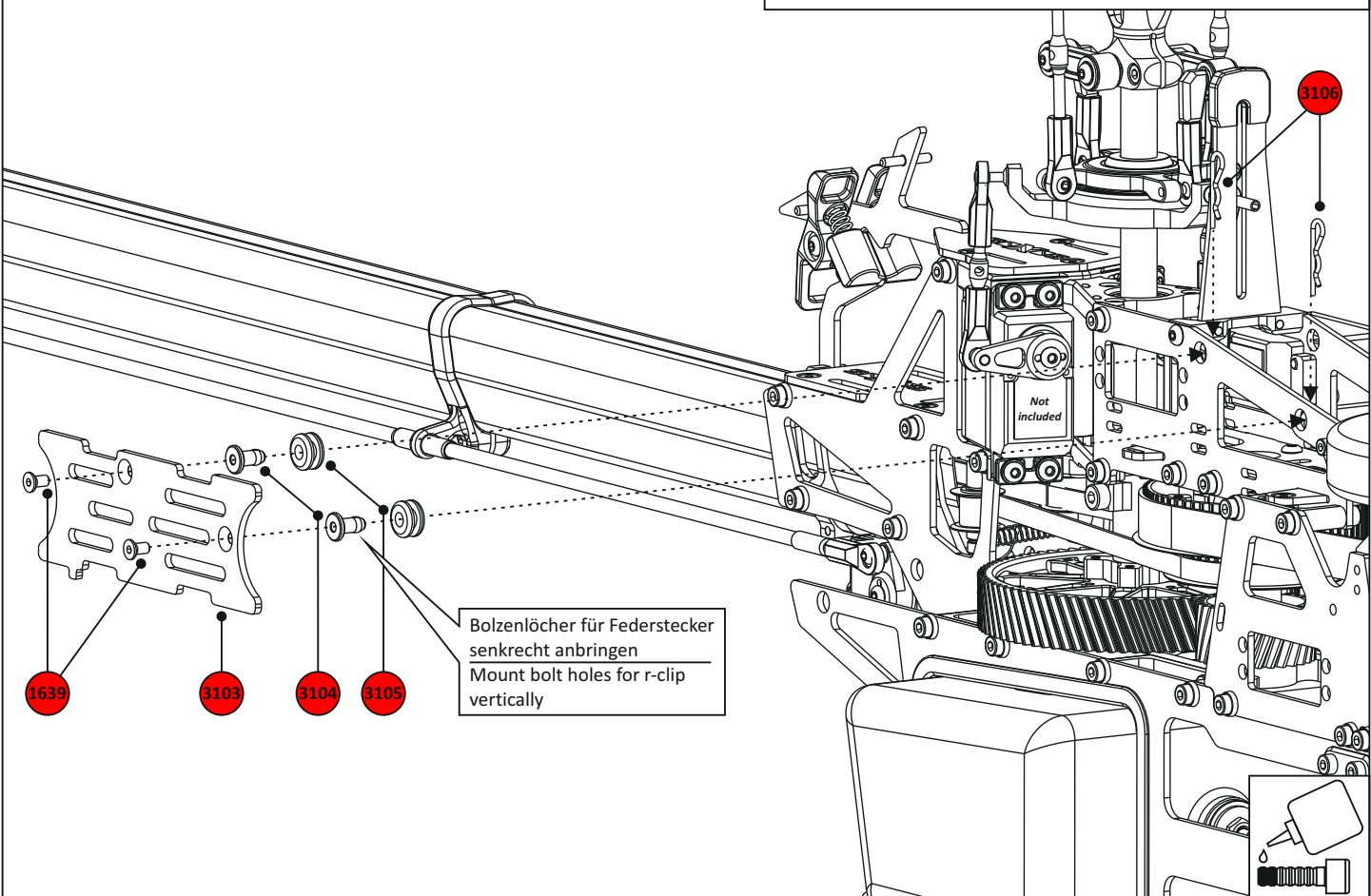

Normteile/Standard Parts

- | | | | |
|------------|---|------------|---|
| 510 | M3x16 Heckrotorblattschraube 2x
Tail Blade Screw | 423 | M5x30 Blatthalterschraube 2x
Blade Screw |
| 18 | M3 Stoppmutter 2x
Lock Nut | 427 | M5 Stoppmutter 2x
Lock Nut |

- | | |
|-------------|---|
| 3040 | Blatthalter U-Scheibe 4x
Blade Holder Washer 1,5mm |
| 3041 | Blatthalter U-Scheibe 4x
Blade Holder Washer 0,5mm |

1:1

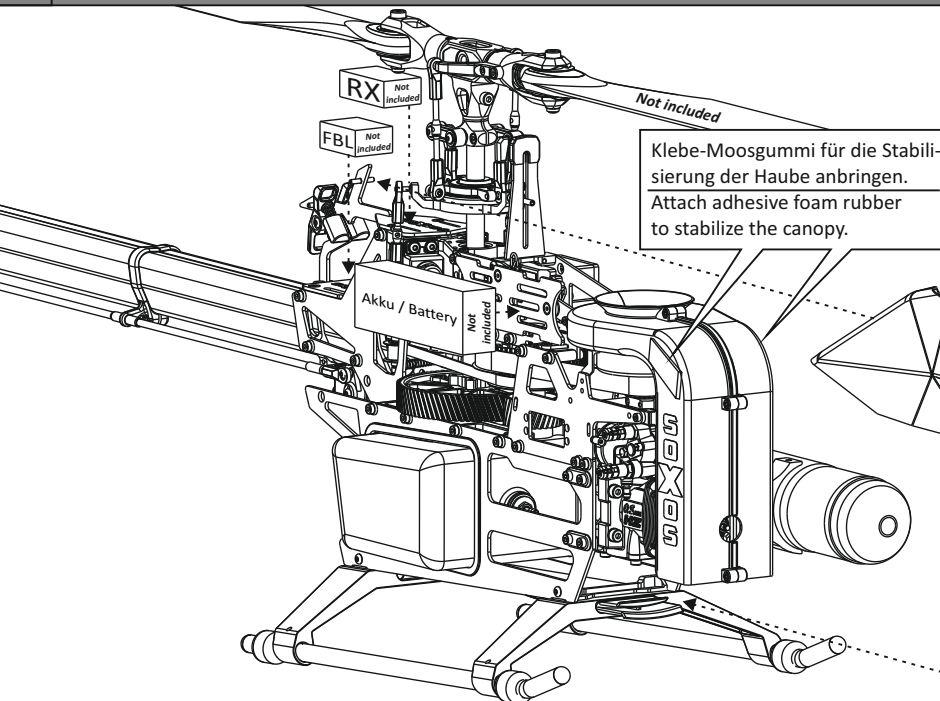
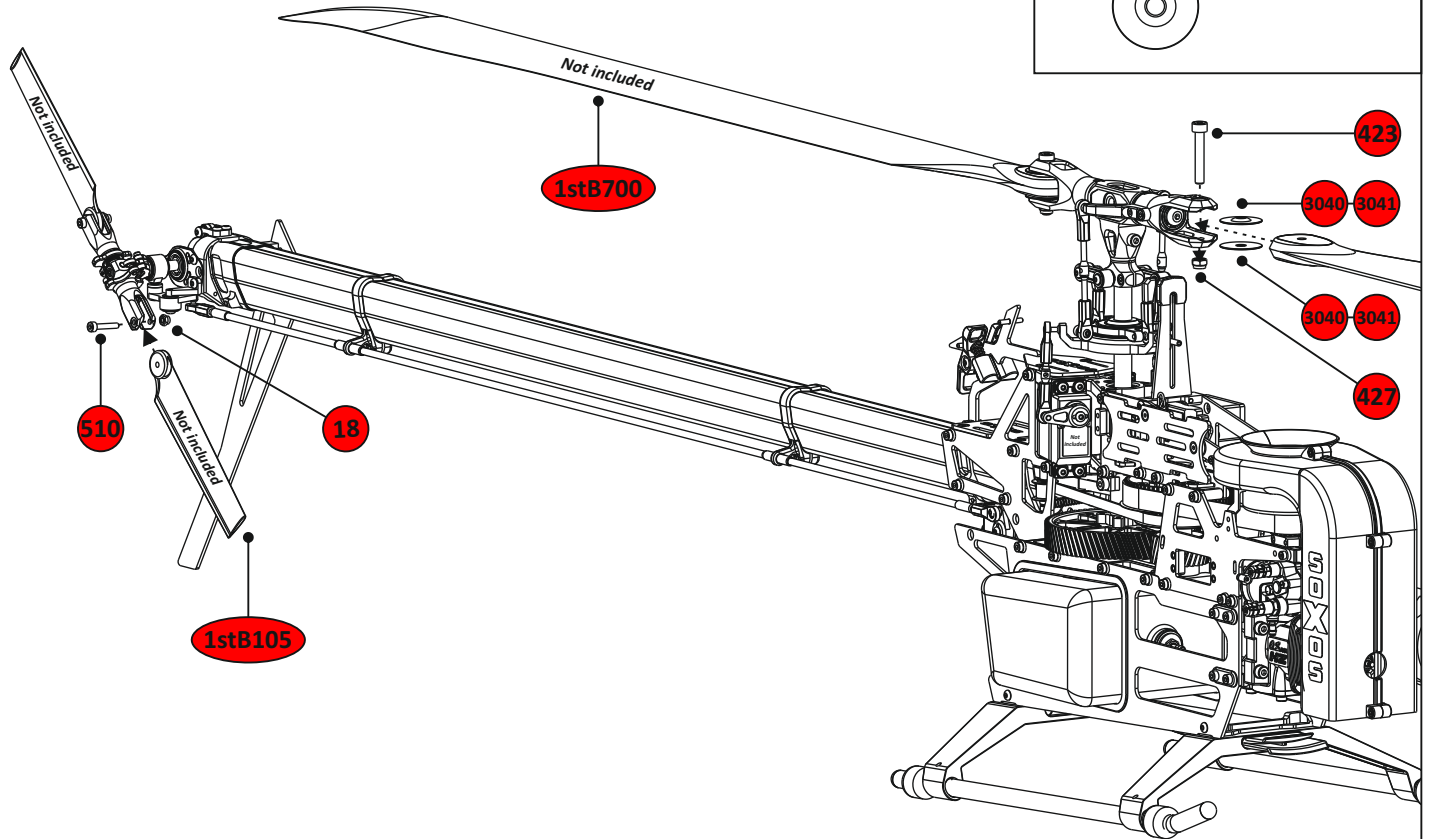

- | | |
|---------------|-------------------------------------|
| 259 N7 | Haube Verbrenner 1x
Canopy Nitro |
|---------------|-------------------------------------|

259 N7

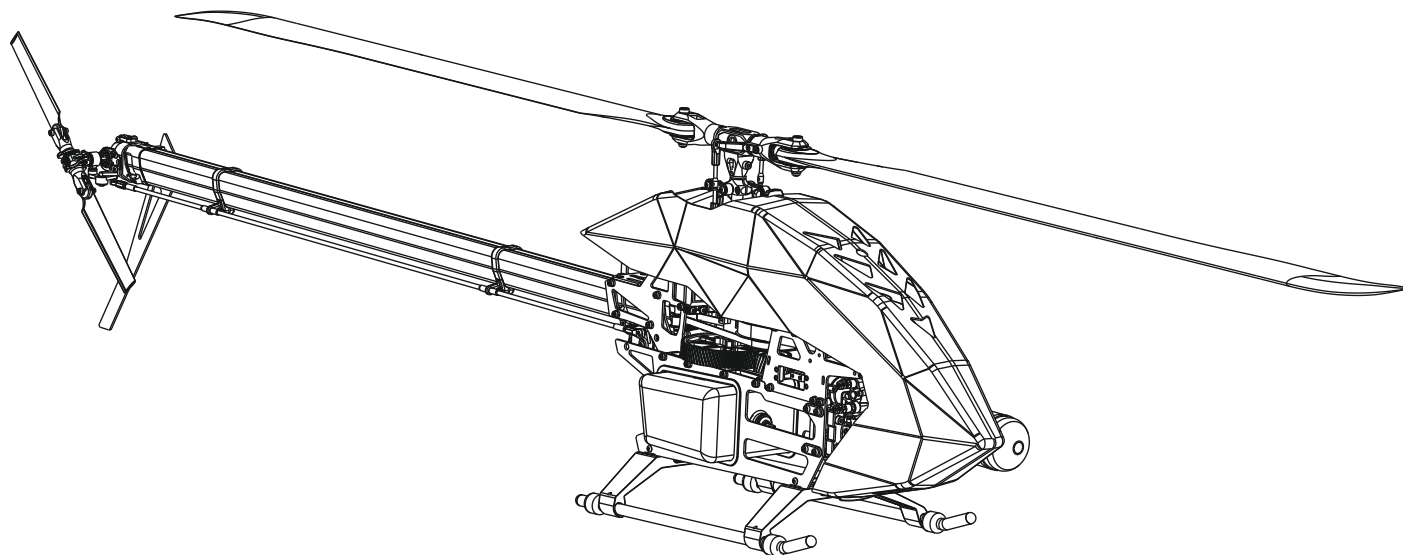

Für Ihre Notizen / For your notes:

Besuchen Sie unsere Homepage www.soxos-heli.com

Dort sind Ersatzteile wie Rotorblätter, Tuningteile, Werkzeuge,
Motoren, Regler, Akkus und Gyros erhältlich.
Die neueste Version dieses Handbuchs können Sie downloaden.

Visit our homepage www.soxos-heli.com

Spare parts such as rotor blades, tuning parts, tools,
motors, controllers, batteries and gyros are available there.
You can download the latest version of this manual.