

**HELI
PROFESSIONAL**

swissengineering RC Helicopter

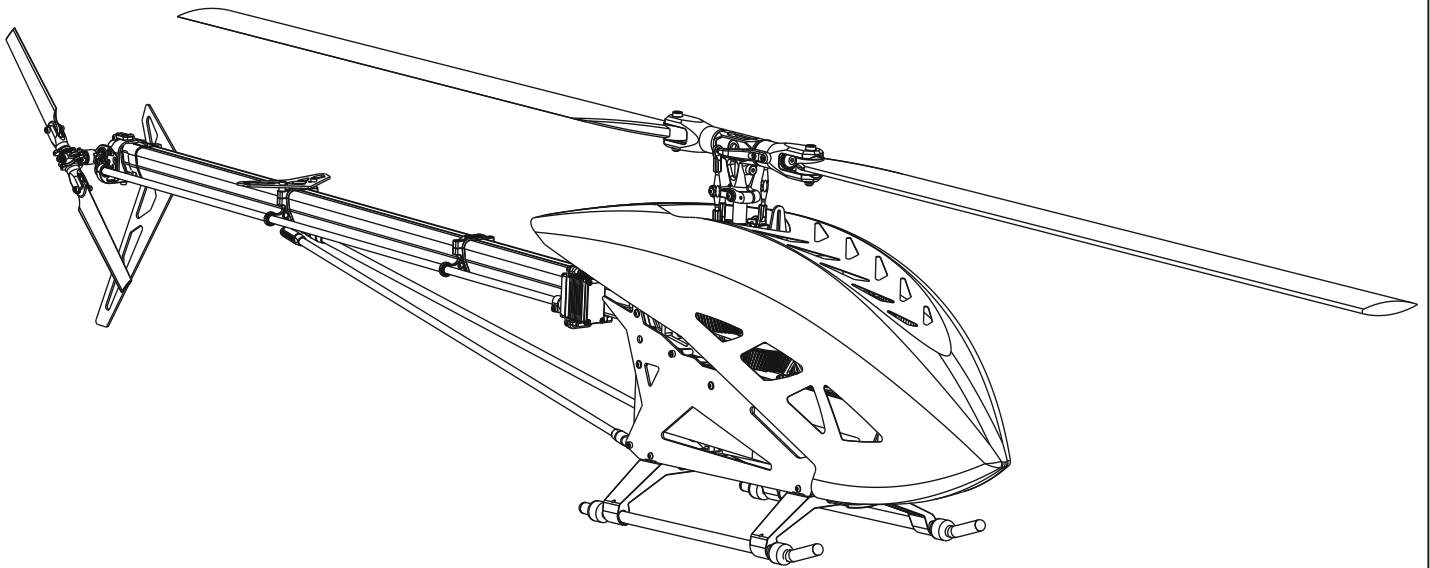

SOXOS STRIKE 7.1

Bauanleitung und Handbuch V 1.2
Assembly Instruction and Manual V 1.2

INHALT/CONTENT

Technische Daten & Sicherheitshinweise/Specifications & Safety Instructions

Benötigtes Werkzeug & Allgemeine Hinweise/Required Tools & General Information

Bauanleitung und Handbuch/Assembly Instructions and Manual

Explosionszeichnung/Exploded view

SEHR GEEHRTER KUNDE

BESTEN DANK, DASS SIE SICH FÜR DEN SOXOS STRIKE 7.1 ENTSCIEDEN HABEN.

Bevor Sie mit dem Zusammenbau oder der Inbetriebnahme beginnen,
lesen Sie diese Anleitung bitte sorgfältig durch!

DEAR CUSTOMER,

THANK YOU FOR CHOOSING THE SOXOS STRIKE 7.1 MODEL HELICOPTER.

Before beginning with the assembly or operating the helicopter,
please read this manual thoroughly!

Technische Daten/Specifications

Hauptrotordurchmesser/Main Rotor Diameter:	ca. 1570mm (mit 690mm Blätter / with 690mm Blades)
Gewicht (ohne Komponenten und Blätter): Weight (without components and blades):	ca. 2180g
Gewicht 12S Setup (ohne Antriebsakku): Weight 12S Setup (without batteries):	ca. 3690g
Länge/Length:	ca. 1380mm
Höhe/Height:	ca. 340mm
Übersetzung Hauptrotor: Gear ratio main rotor:	1:7.94 - 1:10.06 Getriebe Übersetzungen: Ritzel sind kompatibel für 6mm und 8mm Motorwellen Gear Options: Pinions are suitable for 6mm and 8mm motorshafts 15 Zähne/Ratio: 10.06 17 Zähne/Ratio: 8.87 19 Zähne/Ratio: 7.94 16 Zähne/Ratio: 9.43 18 Zähne/Ratio: 8.38
Übersetzung Heckrotor: Gear ratio tail rotor:	1:5.05
Rotorblätter/Main blades:	685mm - 710mm
Heckrotorblätter/Tail blades:	105mm
Maximale Grösse des Motors: Maximum size of the motor:	Ø 63mm, Höhe 64mm, Motorwellenlänge von 20 - 56mm Ø 63mm, height 64mm, motor shaft length from 20 - 56mm
Maximale Abmessung des Antriebs-Akkus: Maximum dimension of the battery:	Breite 62mm, Höhe 68mm, Länge 350mm Width 62mm, Height 68mm, Length 350mm



Sicherheitshinweise:

Ein Modellhubschrauber ist kein Spielzeug, sondern ein sehr leistungsfähiges Flugmodell, das bei unsachgemäßer Bedienung und Wartung grossen Schaden an Mensch und Material verursachen kann. Kinder und Jugendliche sollten einen Modellhubschrauber nur unter Aufsicht eines sachkundigen Erwachsenen bedienen. Heli Professional kann für Haftungs- und Nachfolgeschäden von und mit Erzeugnissen aus dem Lieferprogramm nicht aufkommen und lehnt deshalb jegliche Haftung ab, da ein ordnungsgemäßer Betrieb oder Einsatz unsererseits nicht überwacht werden kann. Zudem bitten wir Sie, sich an die Bedienungsanleitung zu halten und nur Originalersatzteile von Heli Professional zu verwenden.



Safety Instructions:

A model helicopter is a very powerful flying device and not a toy. Disregarding our instructions, inappropriate use, and insufficient maintenance by persons lacking necessary competence may result in injuries for the user and can cause damage to the surroundings and to the model. Children and adolescents should operate a model helicopter only under supervision of an experienced adult. Heli Professional will not accept responsibility for any damage caused by their products and rejects any liability as we are not in a position to supervise proper operation, handling, and maintenance by the user. Furthermore, we ask you to follow our operating and assembly instructions carefully and to use only original Heli Professional parts.

Benötigtes Werkzeug/Required Tools



Innensechskantschlüssel
Hexagon Socket Wrenches
SW 1.5/2/2.5/3



Schraubensicherungslack, mittelfest und fest
Threadlocker, medium and strong

Sekundenkleber
CA (Cyanoacrylic Instant Adhesive)

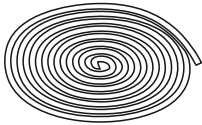

Schnur ca. 2m
String



Fett
Grease

Gabelschlüssel 5.5mm
Flat Wrench

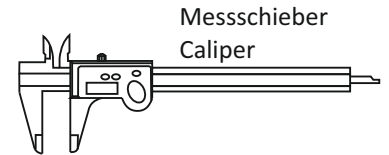
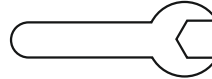

Messschieber
Caliper

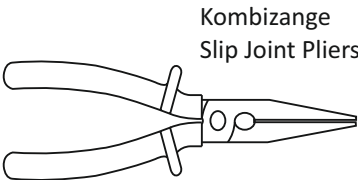

Kombizange
Slip Joint Pliers

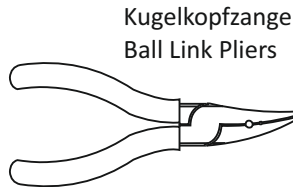

Kugelpkopzange
Ball Link Pliers

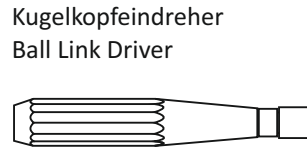

Kugelpkopfeindreher
Ball Link Driver

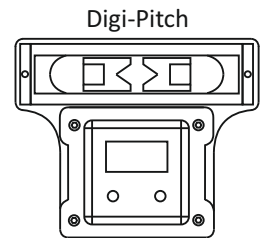

Digi-Pitch

Allgemeine Hinweise/General Information

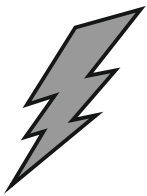

WICHTIG: Bevor Sie mit dem Zusammenbau oder der Inbetriebnahme beginnen, lesen Sie diese Anleitung bitte sorgfältig durch!

IMPORTANT: Before beginning with the assembly or operating the helicopter, please read this manual thoroughly!

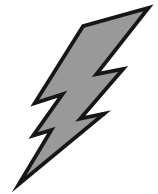

- Es sind keine elektronischen Bauteile, wie z.B. Servos, etc. im Lieferumfang enthalten.
- The kit does not include any electronic components such as servos, etc.

- Grundsätzlich muss jede Schraube entfettet und mit Sicherungslack eingeklebt werden. Auch bereits vormontierte Teile müssen diesbezüglich kontrolliert werden. Das rechts abgebildete Symbol soll Sie während des Zusammenbaus daran erinnern. Kugellager werden NICHT eingeklebt, ausser es wird darauf hingewiesen.
- In general, every screw must be cleaned and secured with threadlocker. Also, check preassembled parts regarding this. The symbol on the right-hand side is supposed to remind you while going through the assembly process. Ball bearings must NOT be secured with threadlocker except where noted.

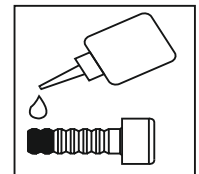

1:1

- Die in den Bauabschnitten mit diesem Symbol abgebildeten Schrauben, etc. sind in Originalgrösse dargestellt.
- The screws and all other parts depicted with this symbol in the assembly steps are actual-size drawings.

- Achten Sie auf die Freigängigkeit aller verbauten Kugellager und Drucklager.
- Check all ball bearings and thrust bearings for ease of movement.

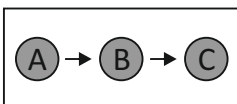
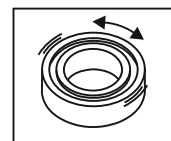

- Montieren Sie die Bauteile in der angegebenen Reihenfolge.
- Assemble the parts in the specified order.

- Wiederholen Sie den Montageschritt so oft wie angegeben (hier: zwei Mal).
- Repeat the assembly step as often as specified (here: twice).

2x

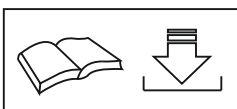





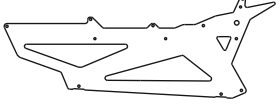
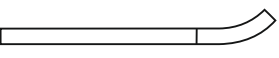

- Handbücher und Bauanleitungen für Tuningteile sind direkt von der Webseite zu beziehen.
- Manuals and assembly instructions for tuning parts are to be downloaded directly from the website. www.soxos-heli.com

Normteile/Standard Parts

- 9 3x7.5 Linsenkopf Treibschraube 8x
Flanged Round Head Self Tapping Screw
- 8 3x12 Treibschraube
Self Tapping Screw 2x
- 92 M3x6 Gewindestift
Set Screw 4x
- 354 M3x8 Rundkopfschraube
Round Head Screw 8x

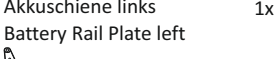
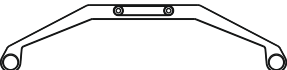
1:1

- 1626 Carbon Seitenplatte
Side Plate Carbon 2x

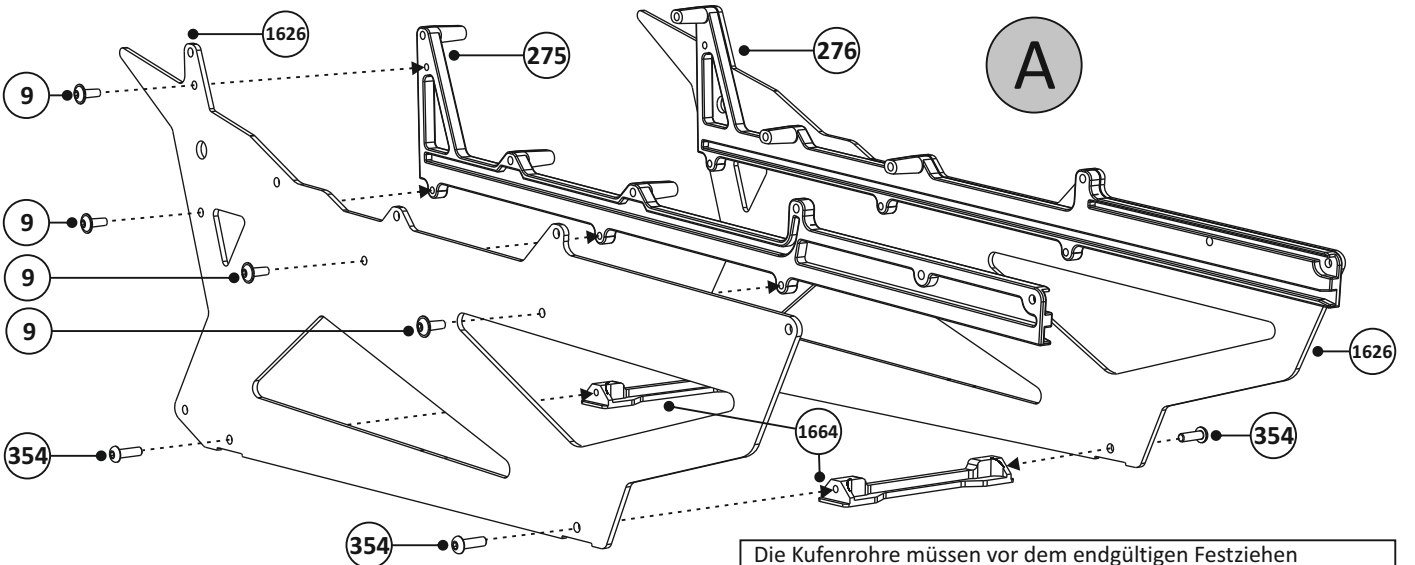
- 436 Kufenrohr
Skid Pipe 2x

- 464 Kufengummi
Skid Rubber 4x

- 275 Akkuschiene rechts
Battery Rail Plate right 1x

- 356 Endkappe Kufenrohr 4x
Skid Pipe Cap 4x

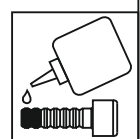
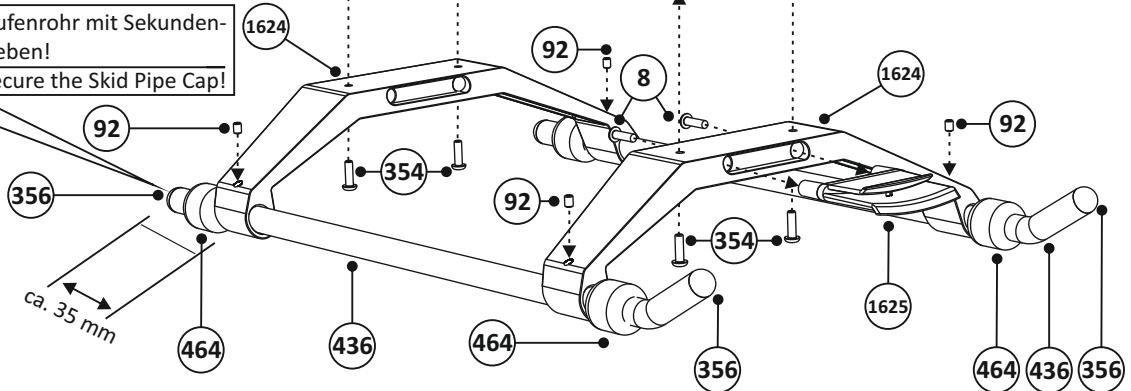
- 1664 Kufenhalterung 2x
Landing Skid Holder 2x

- 276 Akkuschiene links
Battery Rail Plate left 1x

- 1624 Landegestell Weiss
Landing Skid White 2x

- 1625 Haubenhalterung 1x
Canopy Support landing skid 1x



Die Kufenrohre müssen vor dem endgültigen Festziehen plan und ohne Spannungen im Landegestell aufliegen.
Auf einer ebenen Unterlage überprüfen und ggf. justieren!
The landing skid pipes should be checked to make sure they are level and not warped in the landing skids before finally tightening them. Check on a flat surface and adjust if necessary!

B

Endkappe Kufenrohr mit Sekundenkleber einkleben!
Use CA to secure the Skid Pipe Cap!



Normteile/Standard Parts

142 M3x22 Schraube
Hex Socket Screw 2x

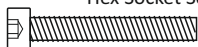

105 M3x18 Schraube
Hex Socket Screw 1x

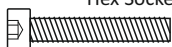

155 M3x6 Rundkopfschraube
Round Head Screw 6x



1705 3x8x3 Flanschlager
Flanged Bearing 6x



1706 Distanzhülse
Distance Sleeve 2x



1741 Feder U-Scheibe
Spring Washer 1x



1738 Distanzhülse
Distance Sleeve 1x

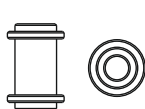

328 12x24x6 Flanschlager
Flanged Bearing 1x

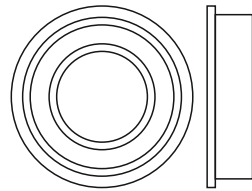

1:1

1777 Adapter Platte
Adapter Plate 1x

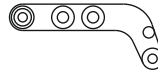

1766 Rahmen
Main Frame 1x

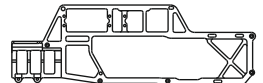

1680-01 Heckriemenführung
Tail Belt Guide 2x



1742 Zugfeder
Extension Spring 1x



1744 Klemmhebel
Gripping Lever 1x



2x **A**

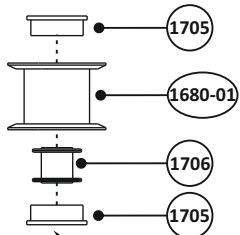

B

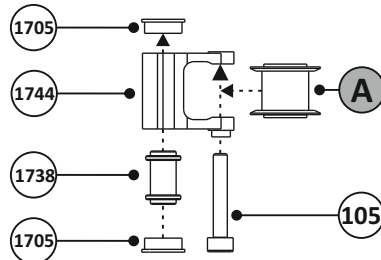

C

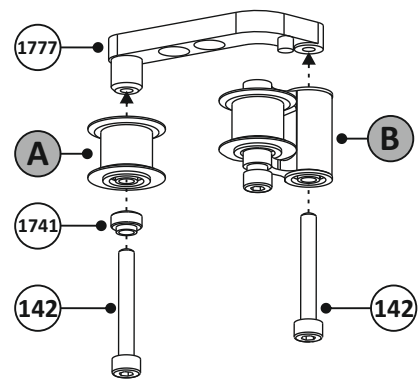

! Alle Kugellager in der Baugruppe A mit Sicherungslack einkleben!
Glue all ball bearings in the assembly A with strong threadlocker!

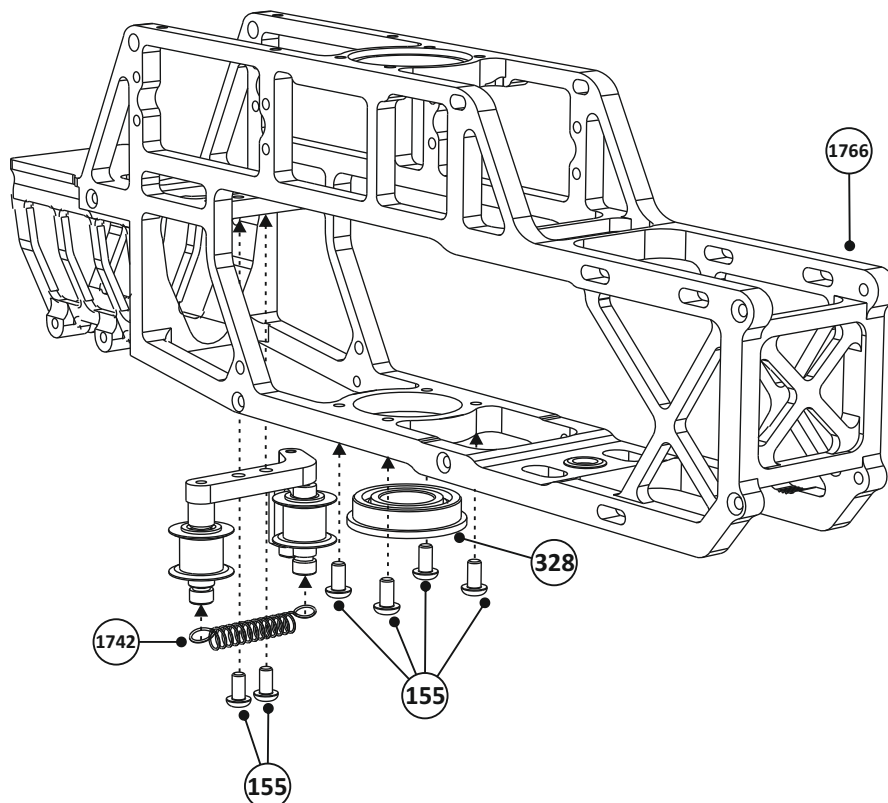

Normteile/Standard Parts

- 354** M3x8 Rundkopfschraube 12x
Round Head Screw

1:1

- 1641-1** Hauptzahnrad Nabe 1x
Main Drive Hub

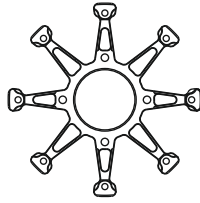

- 1643** Hauptzahnrad 81Z 1x
Main Drive Gear 81T

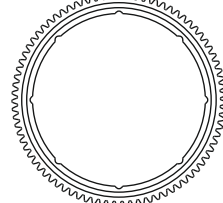

- 1719-02** Flanschmuffe 1x
Flanged Sleeve

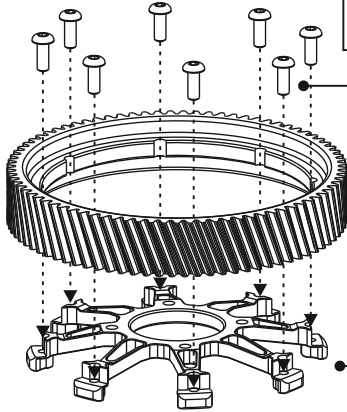
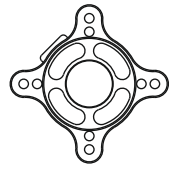

1643

1641-1

354

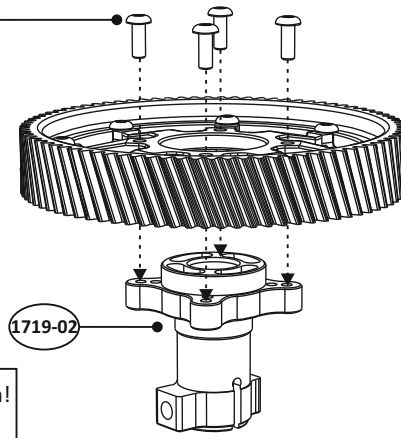

1719-02



Schrauben erst leicht eindrehen, danach gleichmässig anziehen!
First lightly seat the screws, then tighten them evenly!

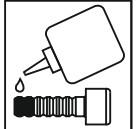

Normteile/Standard Parts

- 155** M3x6 Rundkopfschraube 4x
Round Head Screw



- 488** M5x25 Spezialschraube 1x
Special Screw



- 328** 12x24x6 Flanschlager 1x
Flanged Bearing

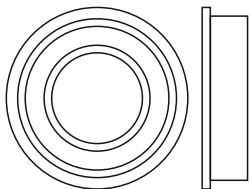

1:1

- 1743-06** Heckriemen 1x
Tail Drive Belt



- 1740** Hauptrotorwelle 1x
Main Shaft

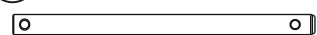

- 1682** Distanzhülse Hauptrotorwelle 1x
Distance Sleeve Main Shaft



- 1592** 12x18x0.1 Passscheiben 2x
Distance Washer



- 1593** 12x18x0.2 Passscheiben 2x
Distance Washer

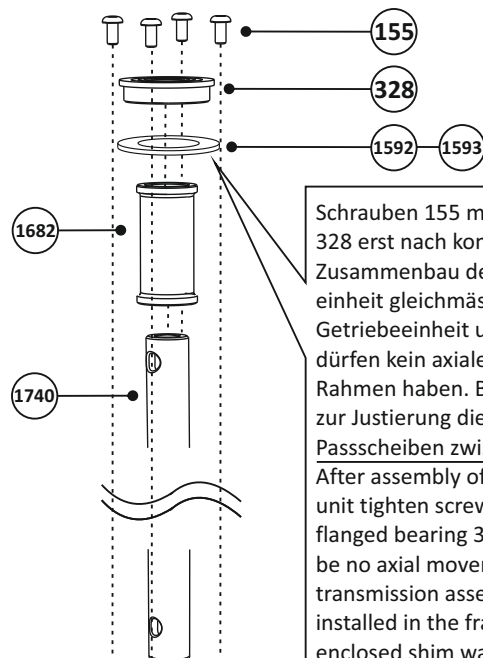

155

328

1592

1593

1682

1740



Schrauben 155 mit Flanschlager 328 erst nach komplettem Zusammenbau der Getriebeeinheit gleichmässig anziehen. Getriebeeinheit und Rotorwelle dürfen kein axiales Spiel im Rahmen haben. Benutzen Sie ggf. zur Justierung die beiliegenden Passscheiben zwischen 328 & 1682.
After assembly of the transmission unit tighten screws 155 on the flanged bearing 328. There must be no axial movement of the transmission assembly when installed in the frame. Use the enclosed shim washers between 328 & 1682 if necessary.

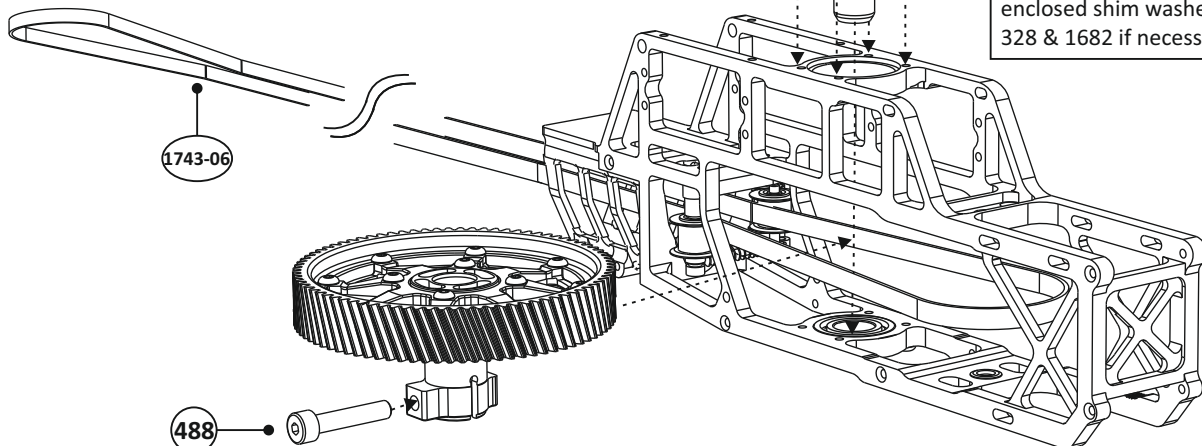

1743-06

488



Normteile/Standard Parts

1720 5x14x5 Kugellager Ball Bearing 4x

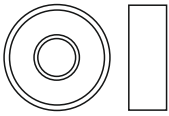

303 M3x8 Zylinderkopfschraube Socket Head Screw 8x



354 M3x8 Rundkopfschraube Round Head Screw 6x



1:1

1636-02 Zahnrad 54Z Drive Gear 54T 1x

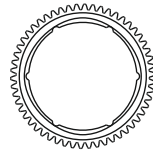

1733 Heckriemenrad 47Z Tail Drive Pulley 47T 1x

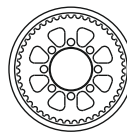

1729 Autorotationsnabe Autorotation Hub 1x

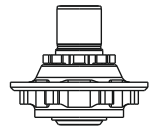

1746 Distanzhülse Distance Sleeve 1x

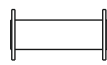

1730 Zahnrad 29Z Drive Gear 29T 1x



Werkseitig bereits montiert und gesichert.
Factory assembled and secured.

Schrauben erst leicht eindrehen, danach gleichmässig anziehen!
First lightly seat the screws, then tighten them evenly!

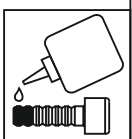
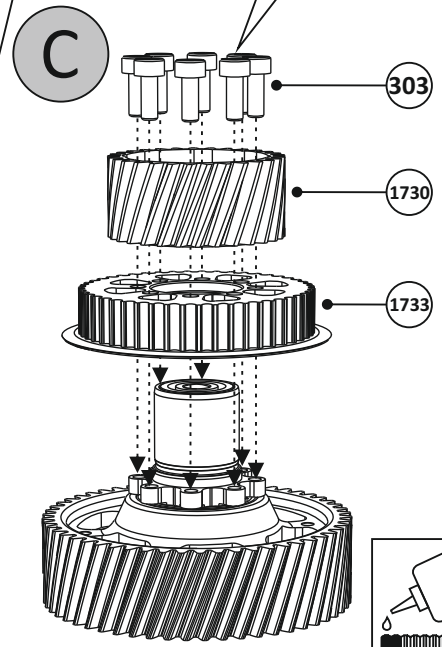
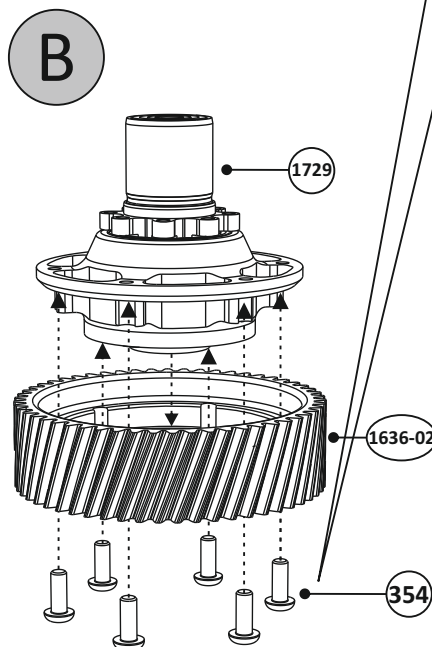
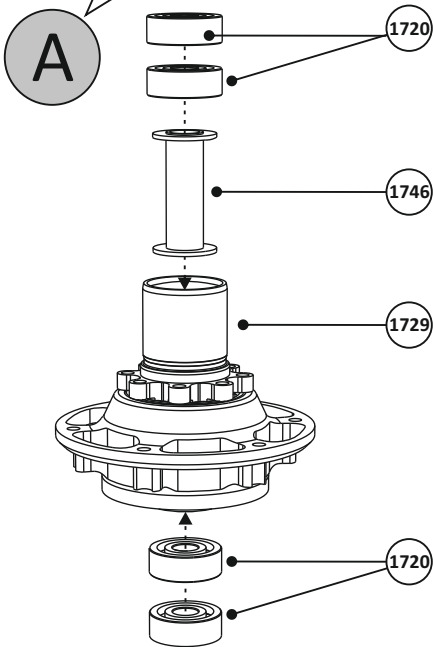

Normteile/Standard Parts

303 M3x8 Zylinderkopfschraube Socket Head Screw 1x



1752 3x11.5x1 U-Scheibe Washer 1x



1:1

1745 Zwischenachse Axel intermediate Gear 1x

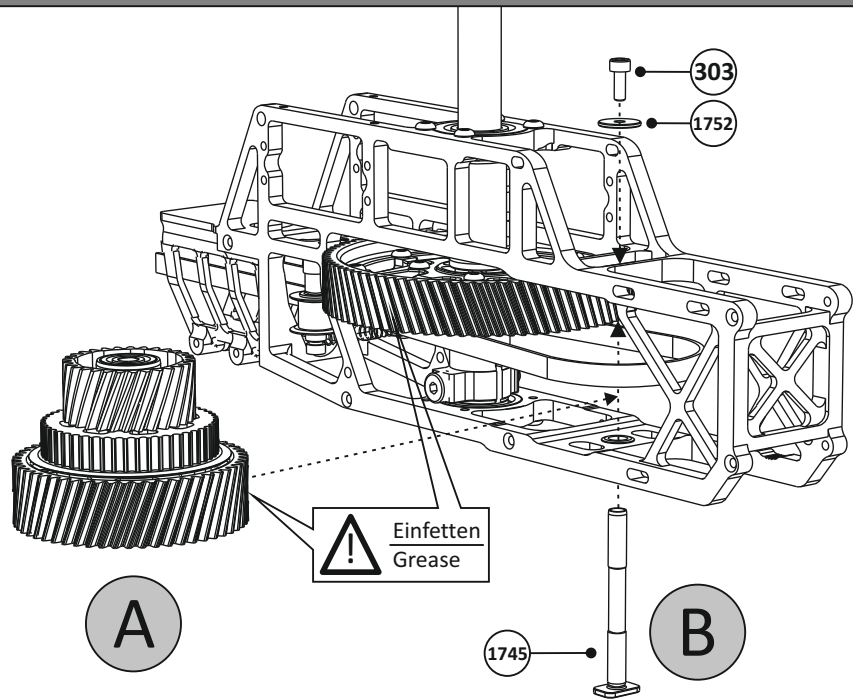
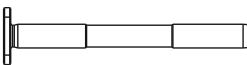

Einfetten Grease

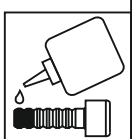

Normteile/Standard Parts

55

M3x25 Zylinderkopfschraube 6x
Socket Head Screw

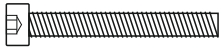

1:1

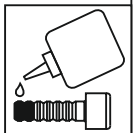
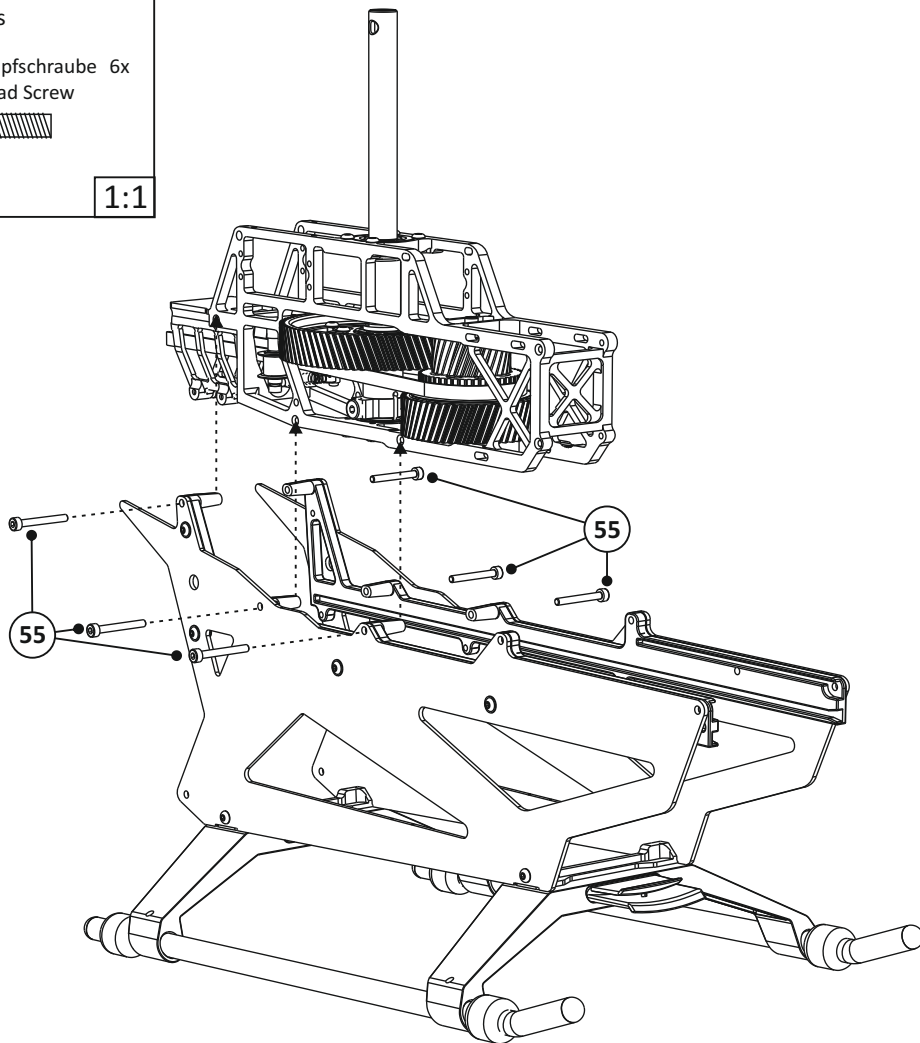

Normteile/Standard Parts

1684

M3x10 Rundkopfschraube 2x
Round Head Screw



155

M3x6 Rundkopfschraube 8x
Round Head Screw



1:1

1551

Vorbaudeckel
Porch Plate Top 1x

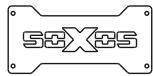

1552

Vorbauboden
Porch Plate Bottom 1x



546

Bolzen Halterplatte
Bolt Box Plate 1x

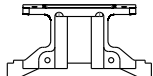

547

Halterung
Porch Holder 1x



318

Verschluss
Latch 1x



350

Druckfeder
Pressure Spring 1x



319

Verschlussgehäuse
Bolt Box 1x

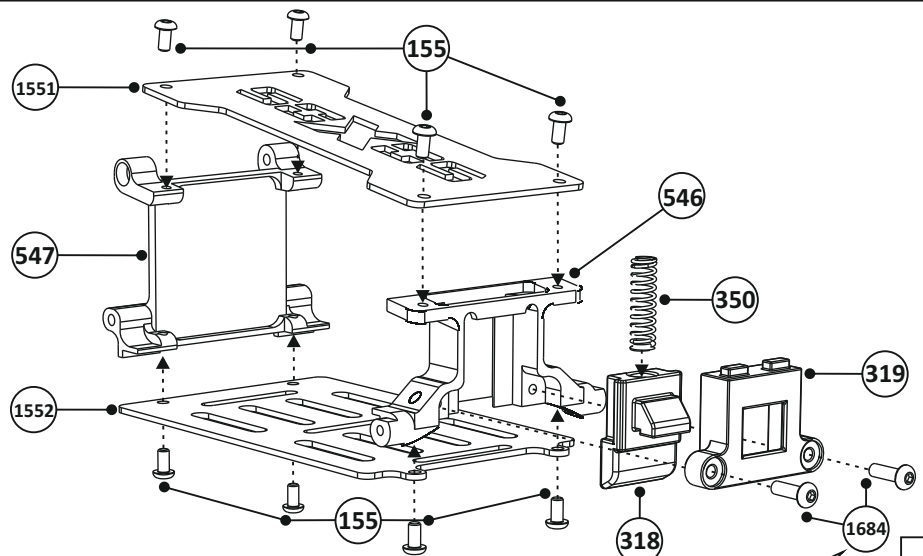
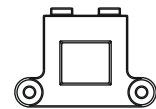

Schraube 1684 nicht zu stark anziehen und auf Leichtgängigkeit des Verschlusses 318 achten!
Do not overtighten screw 1684 to keep smooth movement of latch 318!



Normteile/Standard Parts

55 M3x25 Zylinderkopfschraube 2x
Socket Head Screw

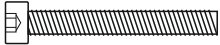

71 M3x10 Zylinderkopfschraube 2x
Socket Head Screw

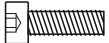





1684 M3x10 Rundkopfschraube 2x
Round Head Screw

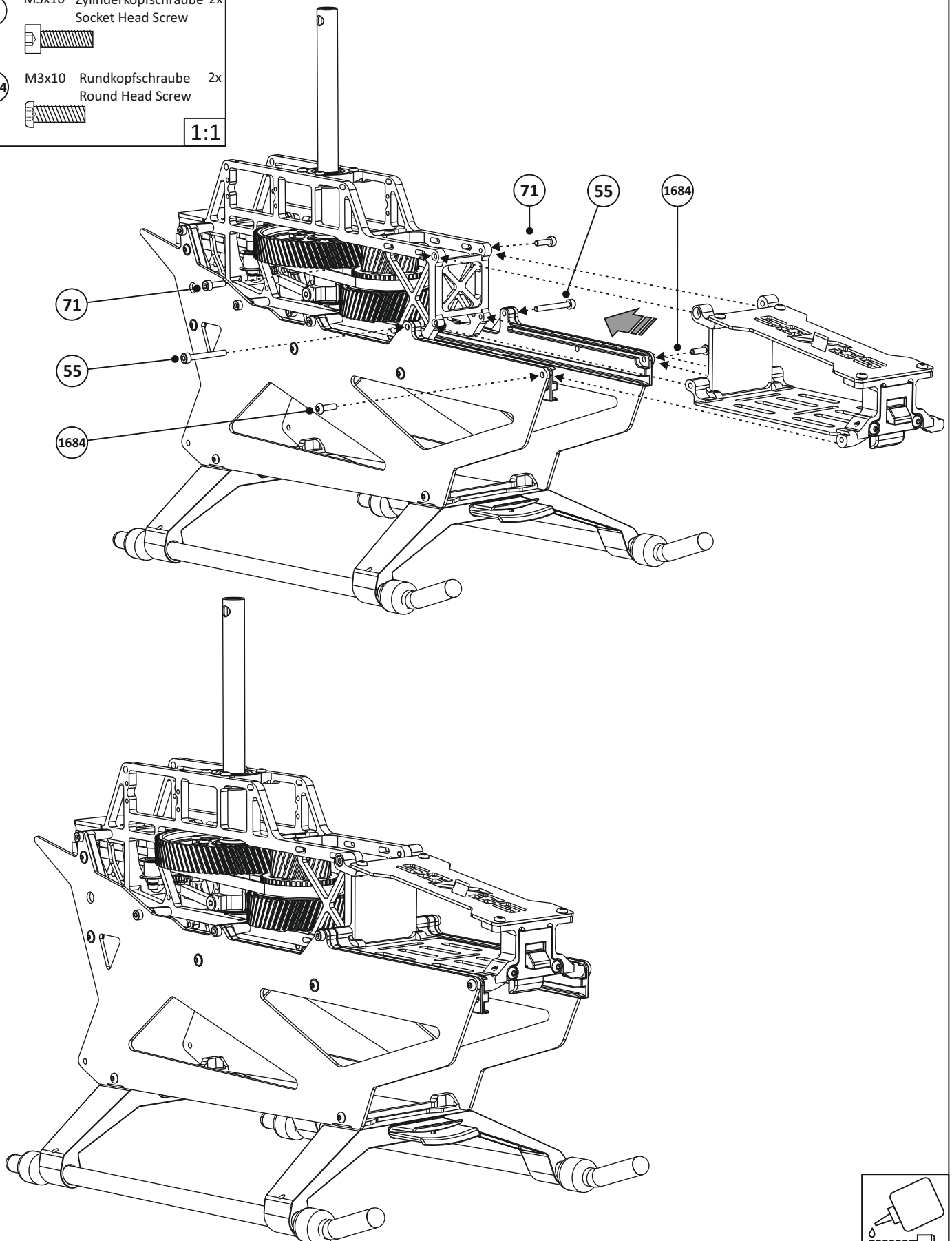

1:1

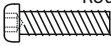

Normteile/Standard Parts

- 1600 M3x12 Rundkopfschraube 4x
 Round Head Screw

- 1601 M3x20 Rundkopfschraube 8x
 Round Head Screw

- 11 M3 U-Scheibe 12x
 Washer

- 145 M3x4.5 Kugelpfopf 3x
 Ball End Screw

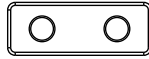
- 354 M3x8 Rundkopfschraube 3x
 Round Head Screw

1:1

137-01

Servodistanz 7 mm 4x
 Servo Distance Block



1665

Servodistanz 9.5 mm 4x
 Servo Distance Block



41

Servoplättchen 10x
 Servo Mounting Plates

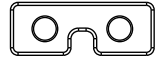

1659

Servo Einsatz 23Z,24Z,25Z,25Z/8
 Insert Servo 23T,24T,25T,25T/8



1797

Servoarm 3x
 Servo Horn

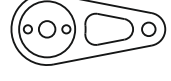

Je nach verwendeten Servos müssen Sie die unterschiedliche Einbautiefe der Servos durch die Verwendung des 7mm oder 9,5mm Servodistanzblocks ausgleichen. Für weitere Anpassungen können Sie die dünneren Servo-Montageplatten verwenden. Wichtig: Verwenden Sie auf jeder Seite die gleiche Anzahl an Servo-Montageplatten. Alle Teile auf Freigängigkeit prüfen. Die Servos dürfen sich nicht in der Mitte des Rahmens berühren. Die Schubstangen sollten so senkrecht wie möglich zur Taumelscheibe sein.



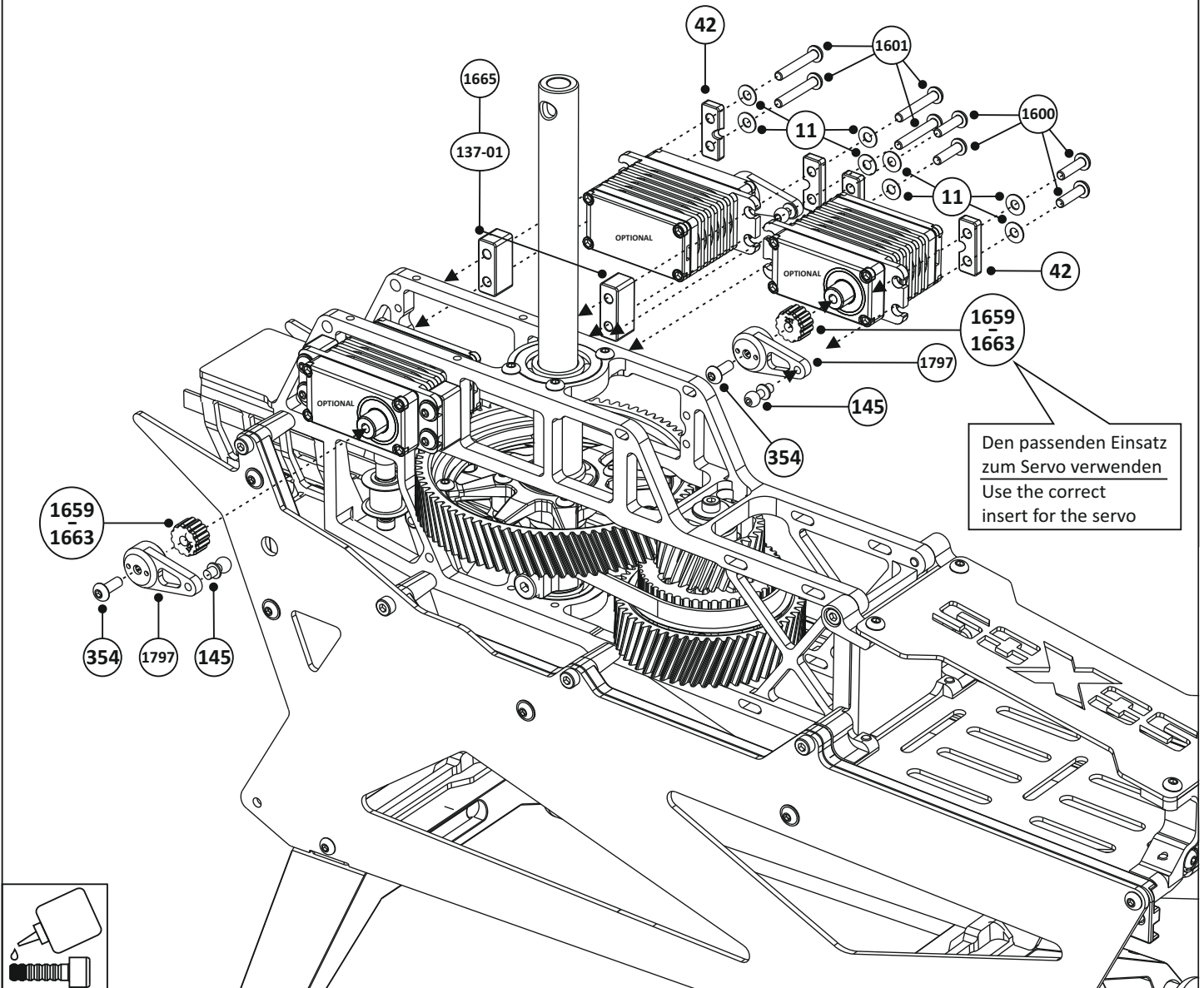

Je nach Art des verbauten Servos können die Schrauben aus der Rahmeninnenseite herausragen.

Depending on the servos used, you must compensate the differing mounting depth of the servos by using the 7mm or 9.5mm servo distance block. For more adjustment you can use the thinner servo mounting plates. Important: Use the same amount of servo mounting plates on each side. Check all parts for ease of movement. The servos must not touch each other in the middle of the frame but the servo to swash links should be as close to vertical as possible.



Depending on the type of servo installed, the screws may protrude from the inside of the frame.



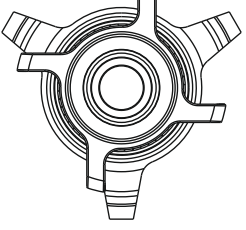

Normteile/Standard Parts

- 309 M3x7 Kugelpfanne Ball End Screw 2x

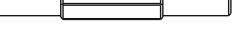
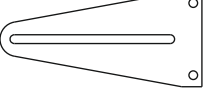
- 145 M3x4.5 Kugelpfanne Ball End Screw 4x

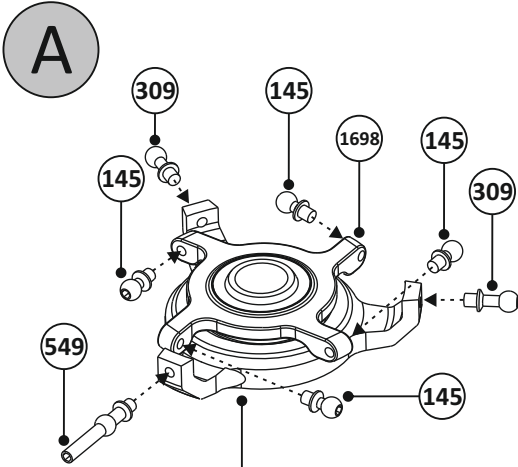
- 549 M3x7 Kugelpfanne lang Ball End Screw long 1x

- 155 M3x6 Rundkopfschraube Round Head Screw 2x

- 303 M3x8 Zylinderkopfschraube 2x Socket Head Screw

1:1

- 359 Kugelpfanne Ball Link 6x

- 1789 Taumelscheibe Swashplate 1x

- 548 Taumelscheibenführungs-Halter Swashplate Guide Holder 1x

- 1798 Schubstange Control Rod 3x

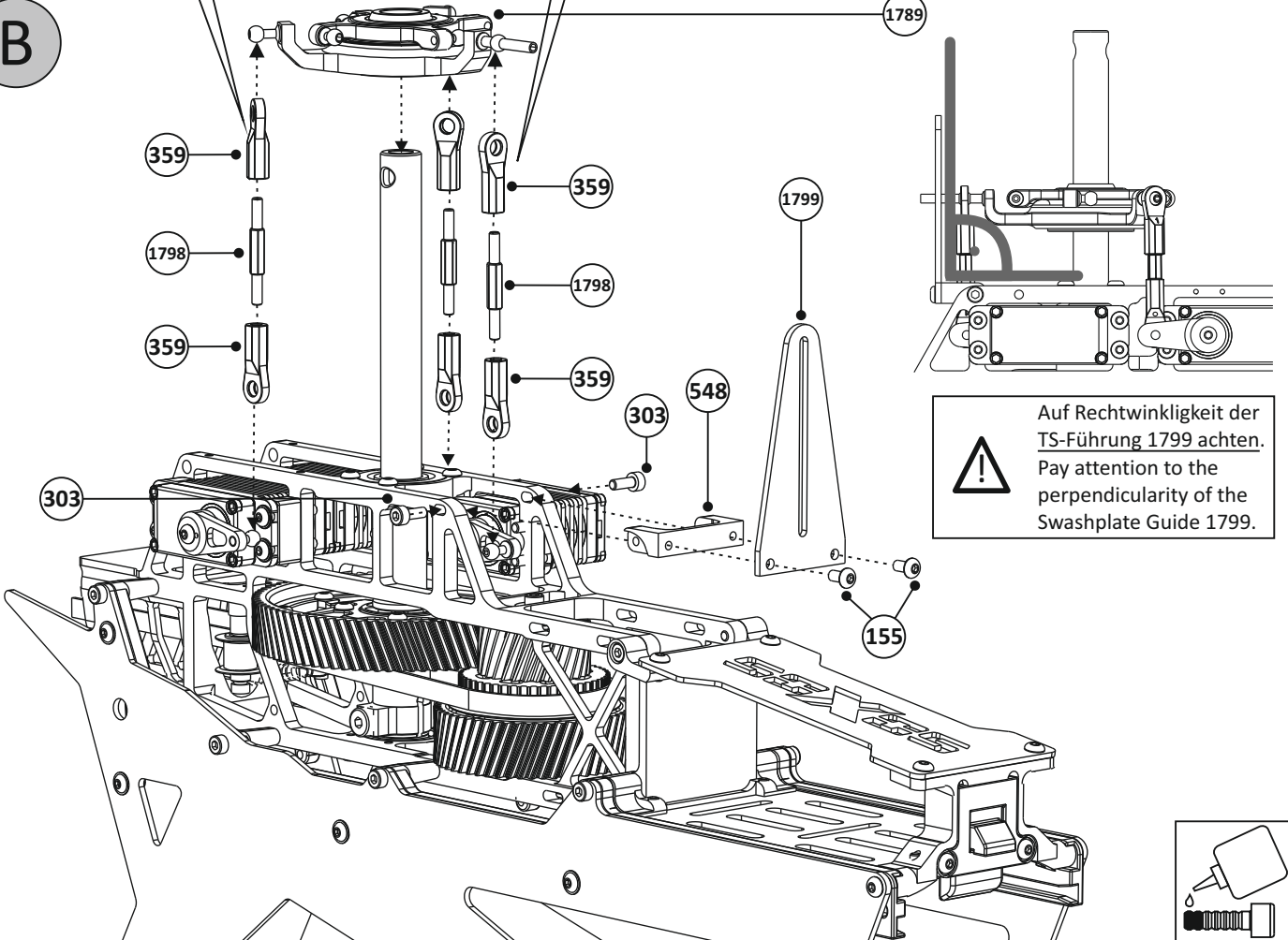
- 1799 Taumelscheibenführung Swashplate Guide 1x



 Schrauben Sie die Kugelpfannen 359 so weit wie möglich auf der Schubstange 1798 zusammen.
Screw ball links 359 together as far as possible on the control rod 1798!

B



 Auf Rechtwinkligkeit der TS-Führung 1799 achten.
Pay attention to the perpendicularity of the Swashplate Guide 1799.



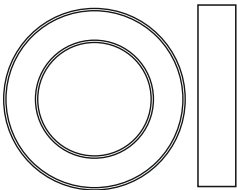

Normteile/Standard Parts

- 1800** 15x24x5 Kugellager 1x
Ball Bearing

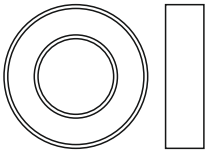

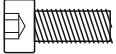
- 417** 10x19x5 Kugellager 1x
Ball Bearing



- 528** M4x10 Zylinderkopfschraube 4x
Socket Head Screw

- 71** M3x10 Zylinderkopfschraube 10x
Socket Head Screw

- 155** M3x6 Rundkopfschraube 4x
Round Head Screw



- 1820** M4x5 Gewindestift 2x
Set Screw



- 11** M3 U-Scheibe 6x
Washer

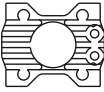

1:1

- 1754** Motorplatte 1x
Motor Plate

 - 1755** Motor Gegenplatte 1x
Motor Counterplate

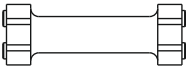

 - 1756** Distanz Platte 1x
Distance Plate

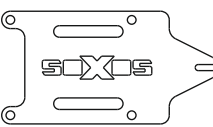
 - 1550 b** Empfängerplatte 1x
Receiver Plate

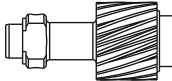
 - 1758** 16z/8mm/6mm Ritzel 1x
Für Motoren von 520-560KV/12S
16T/8mm/6mm Pinion
für Motoren von 520-560KV/12S

- Getriebe Übersetzungen:**
(Ritzel sind erhältlich für 6mm und 8mm Motorwellen)
Gear Options:
(Pinions available for 6mm and 8mm motorshafts)
- 15 Zähne/Ratio:** 10.06
 - 16 Zähne/Ratio:** 9.43
 - 17 Zähne/Ratio:** 8.87
 - 18 Zähne/Ratio:** 8.38
 - 19 Zähne/Ratio:** 7.94

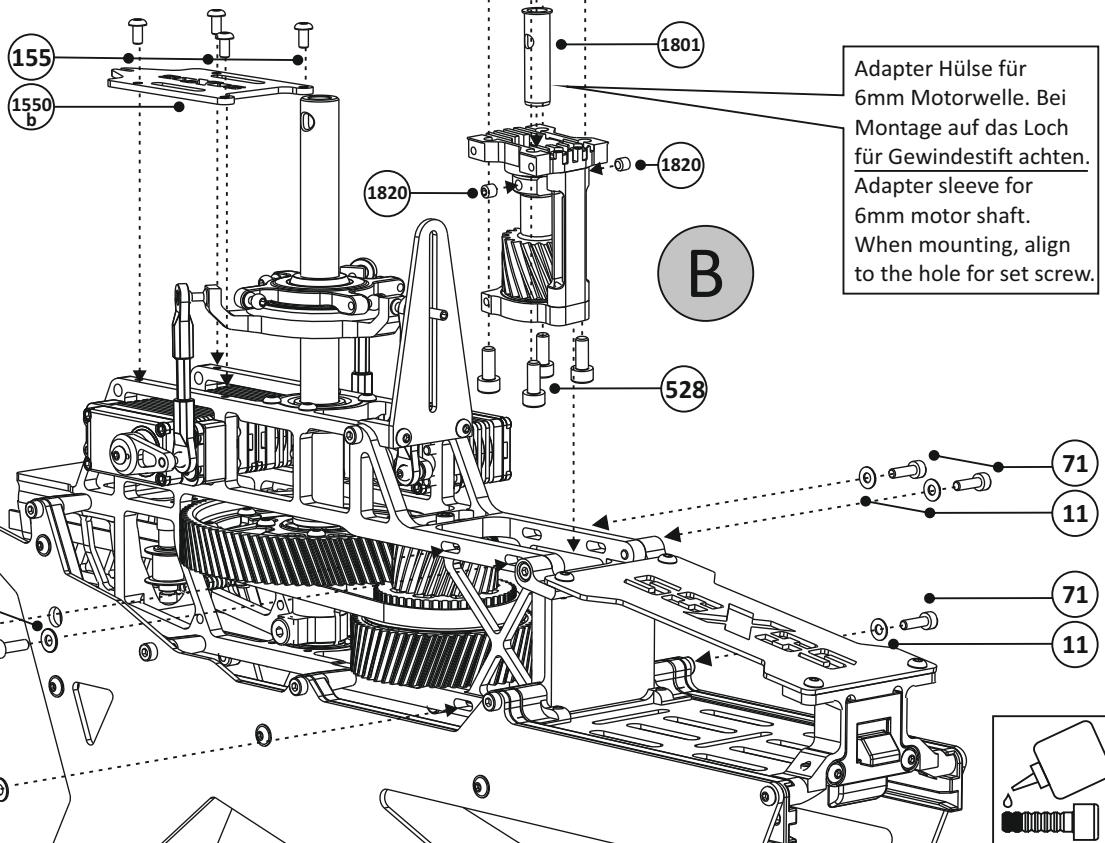
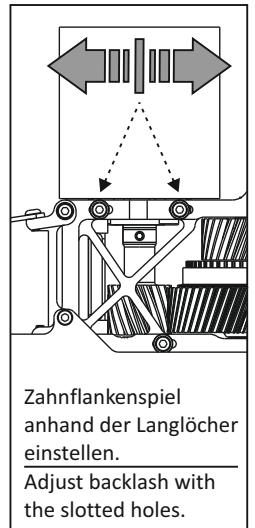
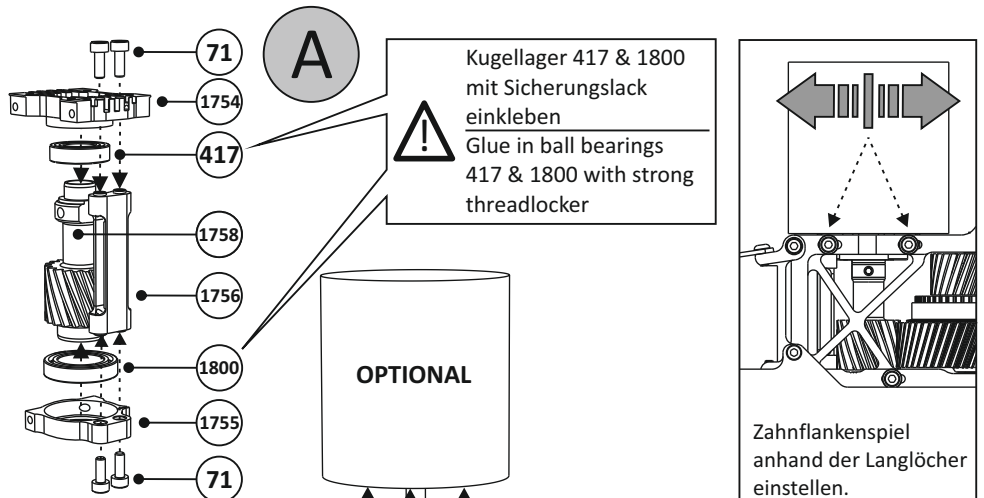
Beim Eindrehen der Motorschraube darauf achten, dass die Wicklungen des Motors nicht verletzt werden. Ggf. andere Schrauben verwenden.
Make sure not to damage the windings with the motor screws. Use different screws if necessary.



Normteile/Standard Parts

54 3x7x3 Flanschlager Flanged Bearing 4x	505 M6x14 Rundkopfschraube Round Head Screw 2x
420 10.2x17.5x1.5 Adapterscheibe Shim Washer 2x	303 M3x8 Zylinderschraube Socket Head Screw 4x
417 10x19x5 Kugellager Ball Bearing 4x	155 M3x6 Rundkopfschraube Round Head Screw 2x
	145 M3x4.5 Kugelformschraube Ball End Screw 2x
	1602 Gewindestift Set Screw M3x12 1x

1:1

416 10x18x5.5 Drucklager Thrust Bearing 2x	1811 Dämpferhülse Damper Sleeve 2x	1813-70 Dämpfer 70° Damper 70° 6x
407b Blattlagerwelle Spindle Shaft 1x	408c Mischebelarm Mixing Lever Arm 2x	1812 Blattlagerwellenführung Spindle Shaft Support 1x

1810 Zentralstück Main Hub 1x	542-02 Blatthalter Blade Holder 2x	1817 Kugelformhalter Ball Link Holder 1x	1556b Mitnehmer Arm Mixing Lever 1x	359 Kugelform Ball Link 1x
---	--	--	---	--------------------------------------

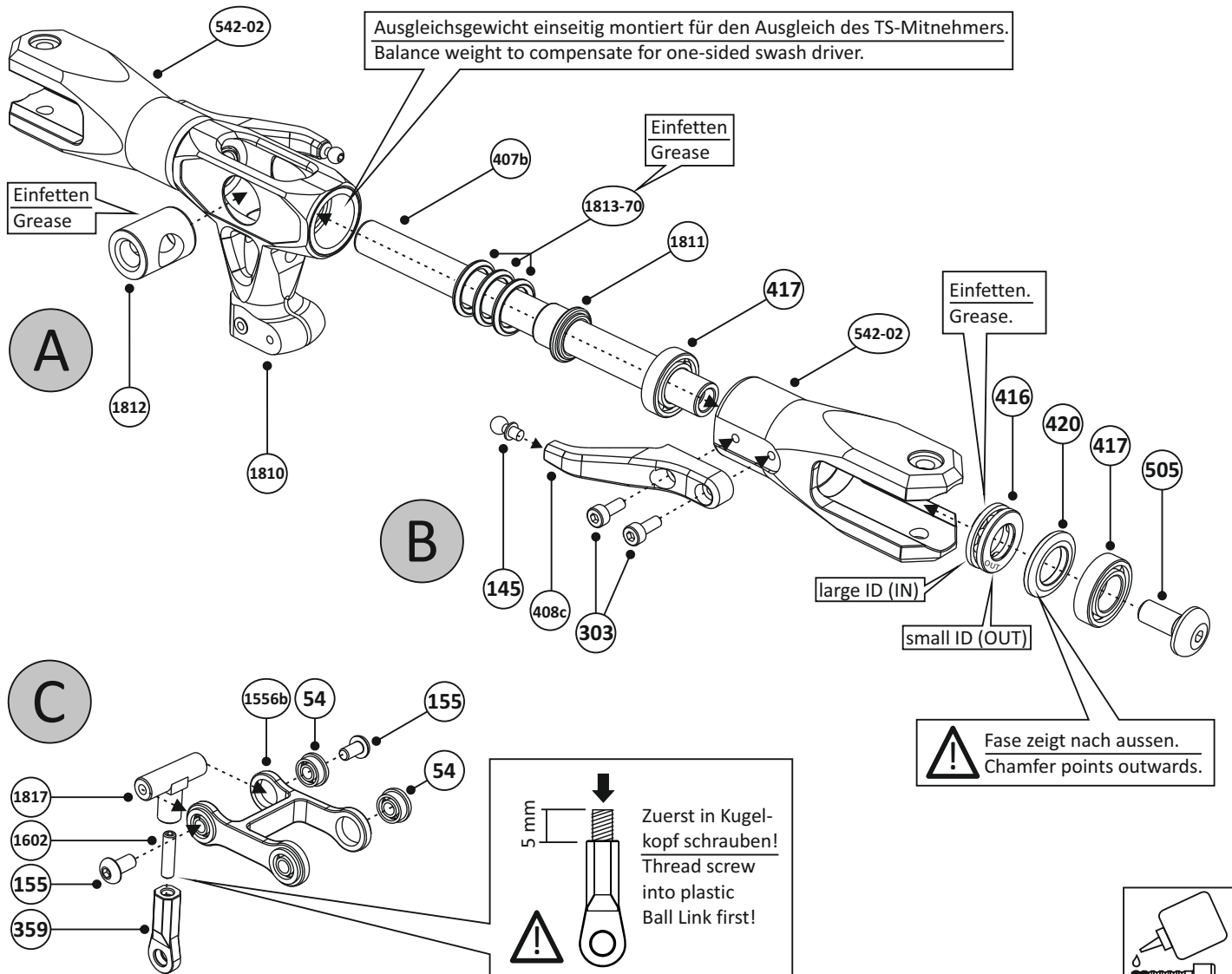

Normteile/Standard Parts

488 M5x25 Spezialschraube 1x
Special Screw

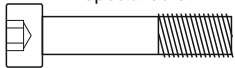

427 M5 Stopmutter 1x
Lock Nut



32 M3x14 Zylinderkopfschraube 1x
Socket Head Screw



155 M3x6 Rundkopfschraube 2x
Round Head Screw



1:1

1809 Anlenkgestänge
(Links-Rechts Gewinde)
Head Linkage Rod
(Left and Right thread)



359 Kugelpfanne
Ball Link

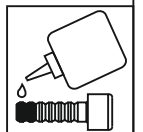
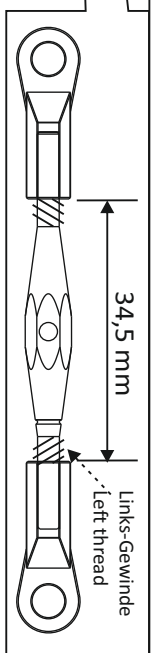
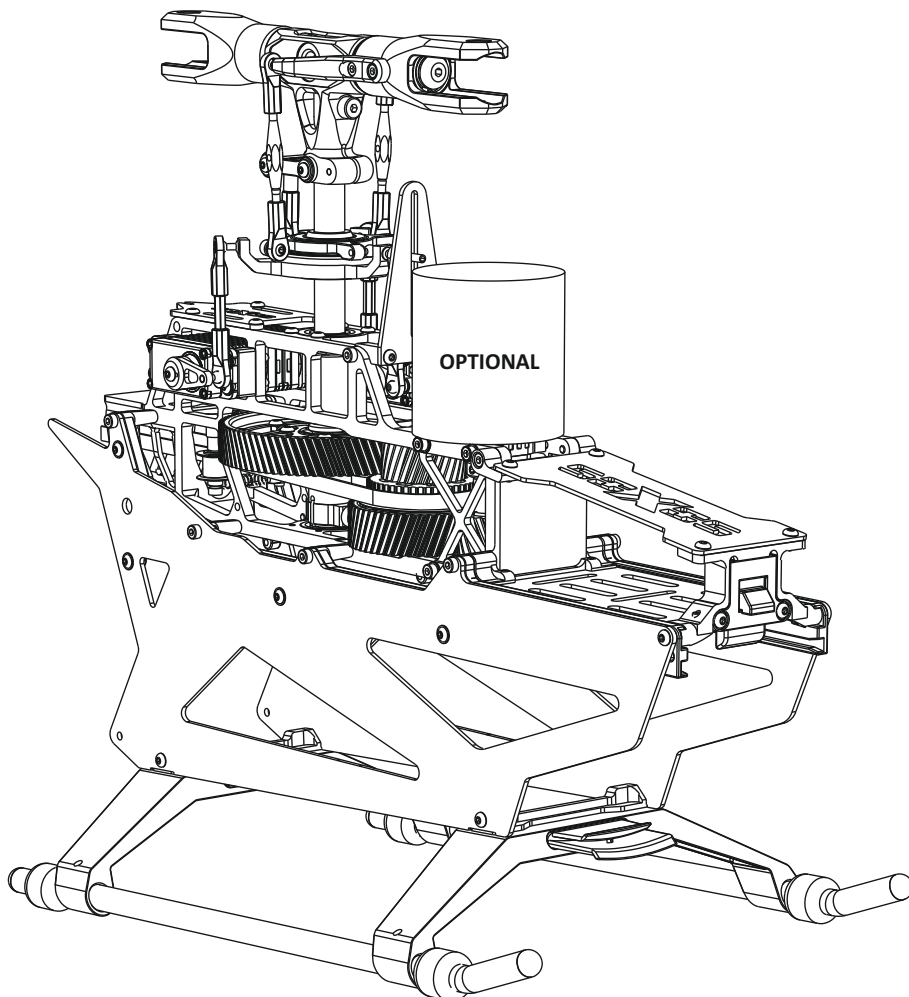
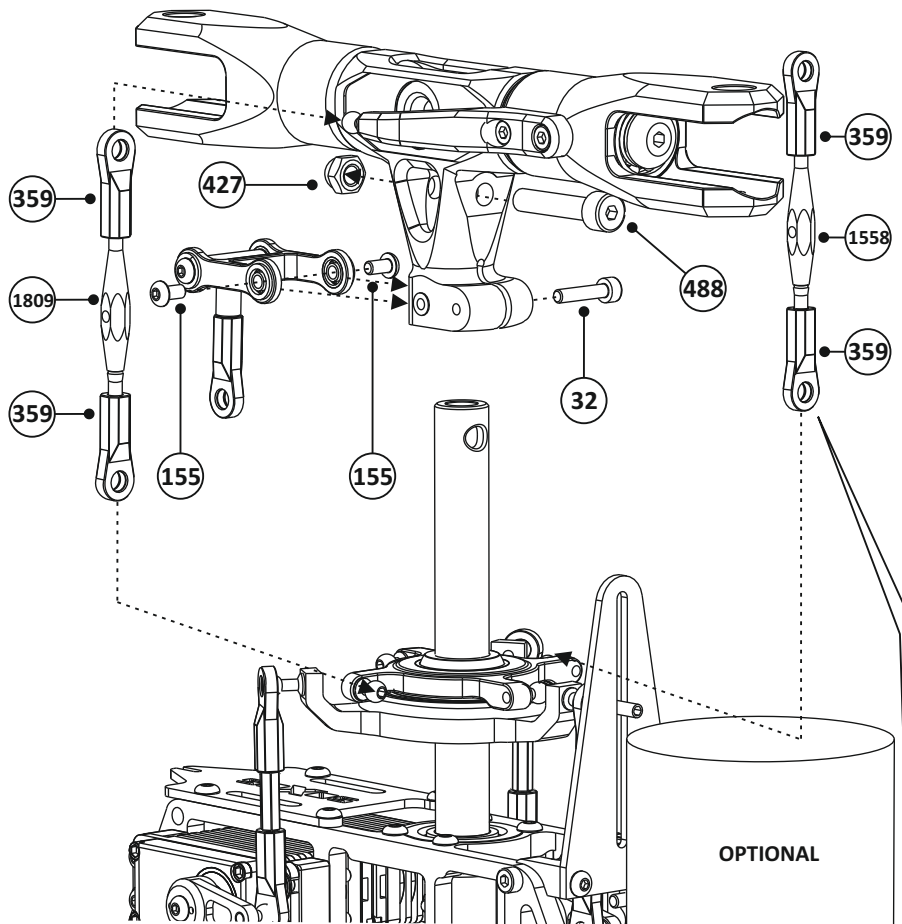
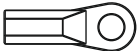

- 1764** Heckrohr 700 1x
Tail Boom 700

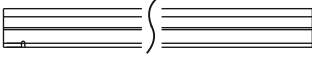
- 1765** Heckrotorgehäuse 1x
Tail Rotor Housing

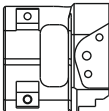

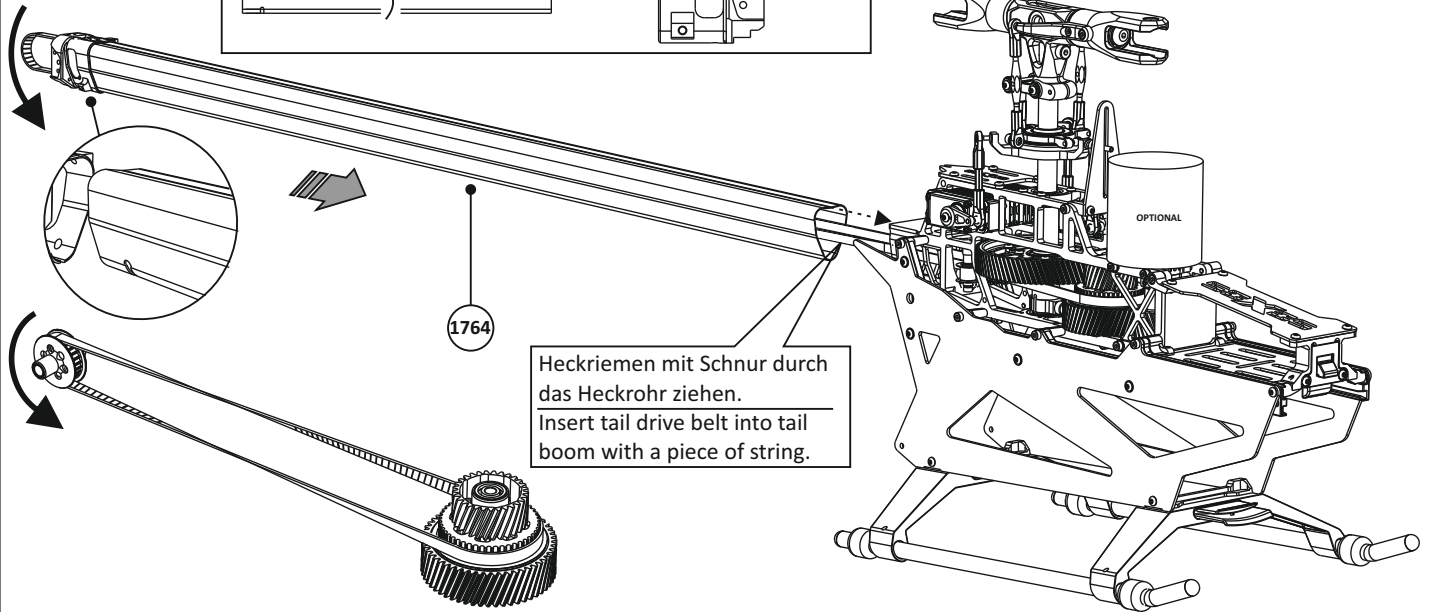

Normteile/Standard Parts

- 155**

M3x6

Rundkopfschraube 2x
Socket Head Screw

- 303**

M3x8

Zylinderkopfschraube 2x
Socket Head Screw

- 383**

8x12x3.5

Kugellager 1x
Ball Bearing



1:1

- 1771** Drehstablagerung Heckgehäuse 1x
Torque Tube Support Tail

- 1767** Seitenplatte Heckgehäuse 1x
Tail Rotor Housing Side Plates



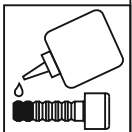
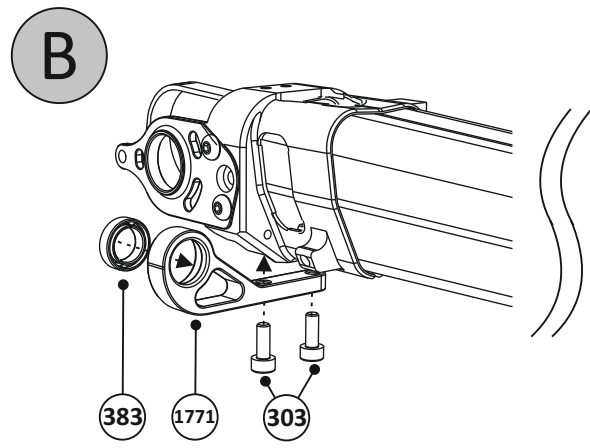
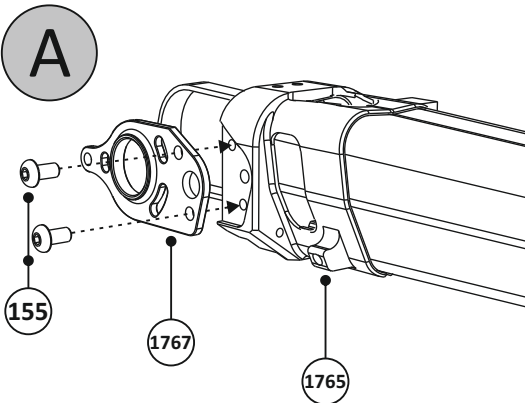

Normteile/Standard Parts

- 1600 M3x12 Rundkopfschraube 4x
Round Head Screw
- 71 M3x10 Zylinderkopfschraube 3x
Socket Head Screw
- 303 M3x8 Zylinderkopfschraube 1x
Socket Head Screw
- 11 M3 U-Scheibe 4x
Washer

1:1

- 1778 Halterklemme 1x
Holder Clamp
- 1776 Heckservohalter 1x
Tail Servo Holder
- 1658 Drehstabhebel 1x
Torque Tube Lever
- 41 Servoplättchen 2x
Servo Mounting Plates
- 1659-1663 Servo Einsatz 23Z,24Z,25Z,25Z/8
Insert Servo 23T,24T,25T,25T/8

Den passenden Einsatz zum Servo verwenden
Use the correct insert for the servo

Erst beim Programmieren des Heckservos endgültig anziehen.
Tighten fully after centring the tail servo, apply threadlocker.

Drehstab ganz nach vorne schieben.
Push the Torque Tube all the way to the front.

Servo ganz nach hinten schieben.
Push the servo all the way back.

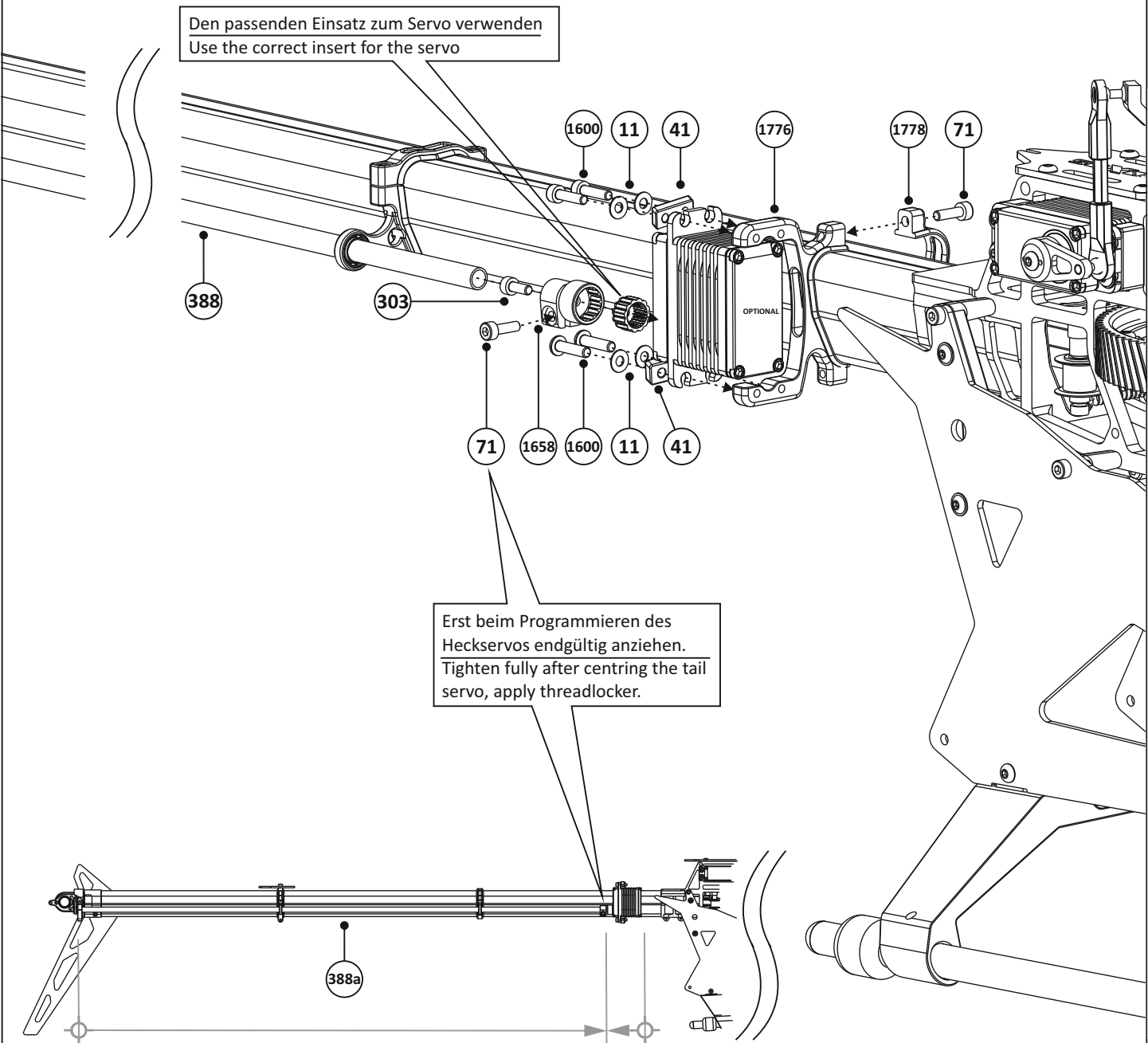
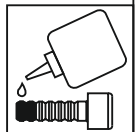

Normteile/Standard Parts

- 1787** M3x35 Rundkopfschraube 1x
Round Head Screw
- 17** M3x20 Zylinderkopfschraube 2x
Socket Head Screw
- 149** M3x12 Zylinderkopfschraube 1x
Socket Head Screw
- 71** M3x10 Zylinderkopfschraube 2x
Socket Head Screw
- 155** M3x6 Rundkopfschraube 1x
Round Head Screw
- 296** 7x11x3 Kugellager 2x
Ball Bearing
- 11** M3 U-Scheibe 1x
Washer

1:1

- 1668** Carbon Höhenleitwerk 1x
Carbon Stabilizer Fin
- 266** Steuerhebel 1x
Tail Lever
- 388a** Drehstab 1x
Torque Tube
- 1780** Drehstablagerung 1x
Torque Tube Support
- 1781** Halterklemme oben 2x
Upper Holder Clamp
- 1782** Höhenleitwerkhalterklemme unten 1x
Lower Stabilizer Fin Clamp
- 1667** Carbon Seitenleitwerk 1x
Carbon Vertical Fin
- 448** Höhenleitwerksdistanz 2x
Stabilizer Fin Spacer

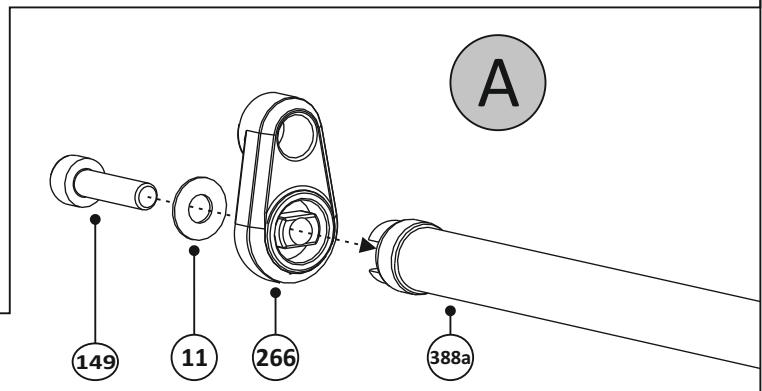

A

Diese Schrauben erst nach Montage der Heckstreben anziehen.
Clamp with these screws after having installed the tail brace tubes.

Drehstablagerung am Ende der Heckrohr Design-Linien montieren.
Torque Tube Support mount at the end of the tail boom design lines.

B

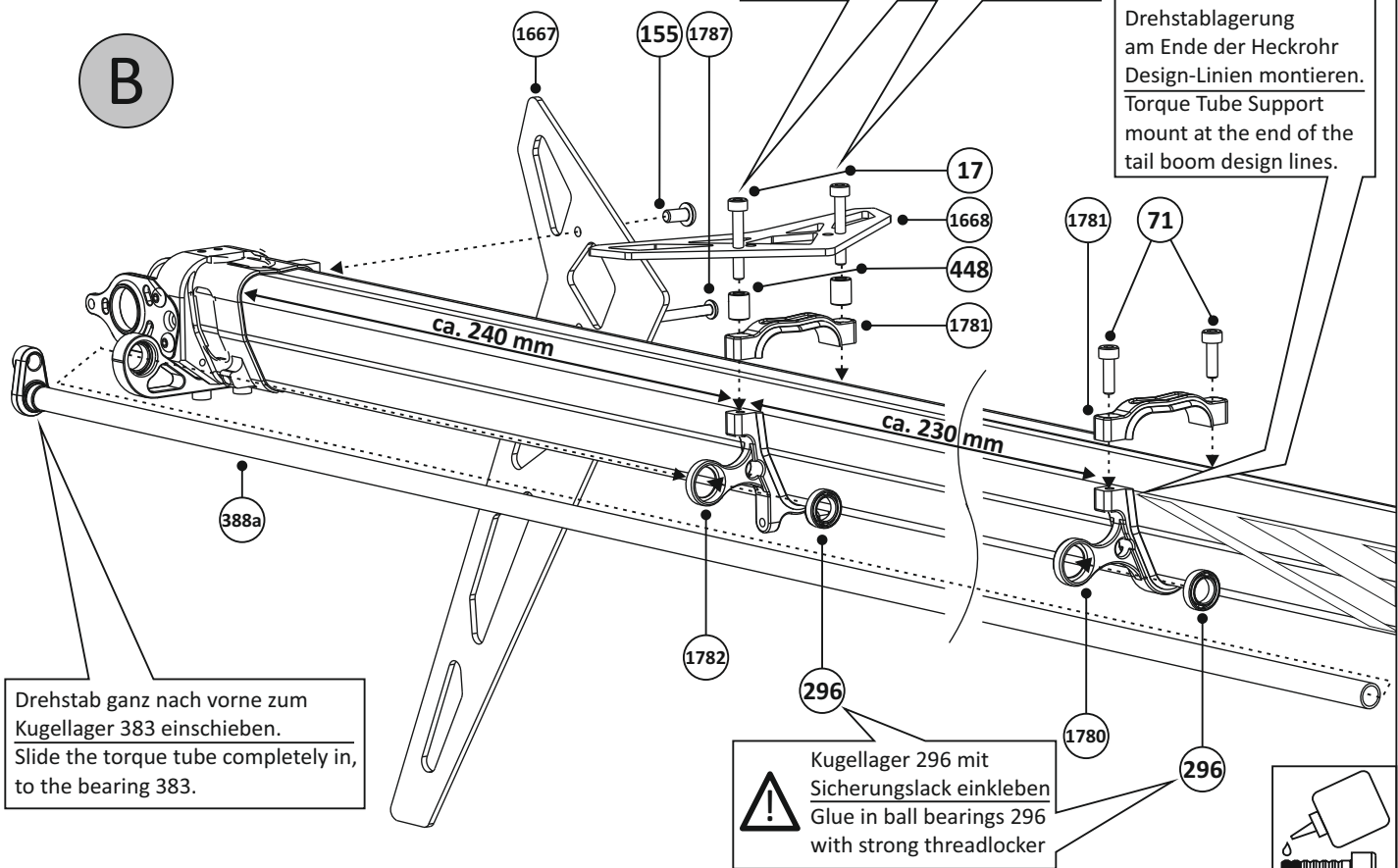

Drehstab ganz nach vorne zum Kugellager 383 einschieben.
Slide the torque tube completely in, to the bearing 383.

! Kugellager 296 mit Sicherungslack einkleben
Glue in ball bearings 296 with strong threadlocker

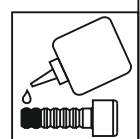

Normteile/Standard Parts

- | | | | | | |
|------------|--------------------------------------|----|------------|--|----|
| 145 | M3x4.5 Kugelbolzen
Ball-End Screw | 3x | 69 | 7.5x9.9x0.4 Passscheibe
Shim Washer | 2x |
| 444 | 5x1 O-Ring | 2x | 443 | 5.2x7.5x0.7 Passscheibe
Shim Washer | 2x |
| 68 | 5x10x4 Kugellager
Ball Bearing | 2x | 503 | M2x5.5 Zylinderkopfschraube
Socket Head Screw | 2x |
| 74g | 6x10x3 Kugellager
Ball Bearing | 2x | 303 | M3x8 Zylinderkopfschraube
Socket Head Screw | 2x |

- | | | | | | |
|---------------|-------------------------------------|----|-------------|--|----|
| 1711-1 | Heckrotornabe
Tail Rotor Hub | 1x | 1704 | Blatthalter Heckrotor
Blade Holder Tail Rotor | 2x |
| 151 | 5x10x4 Drucklager
Thrust Bearing | 2x | 1773 | Hecksteuerbrücke
Tail Pitch Control | 1x |
| | large ID (IN) | | | | |
| | small ID (OUT) | | | | |
| 70 | 3x7.5x1 Unterlegscheibe
Washer | 2x | 268 | Hecksteuerbrückenarme
Tail Pitch Control Arms | 2x |

1:1

Punkt auf 268 muss Richtung Schraubenkopf 503 sein.
Raised dot on 268 must be in direction screw head 503.

Kugellager werksseitig bereits montiert.
Ball bearing already assembled.

Einfetten.
Grease.

Werksseitig bereits montiert und gesichert.
Factory assembled and secured.

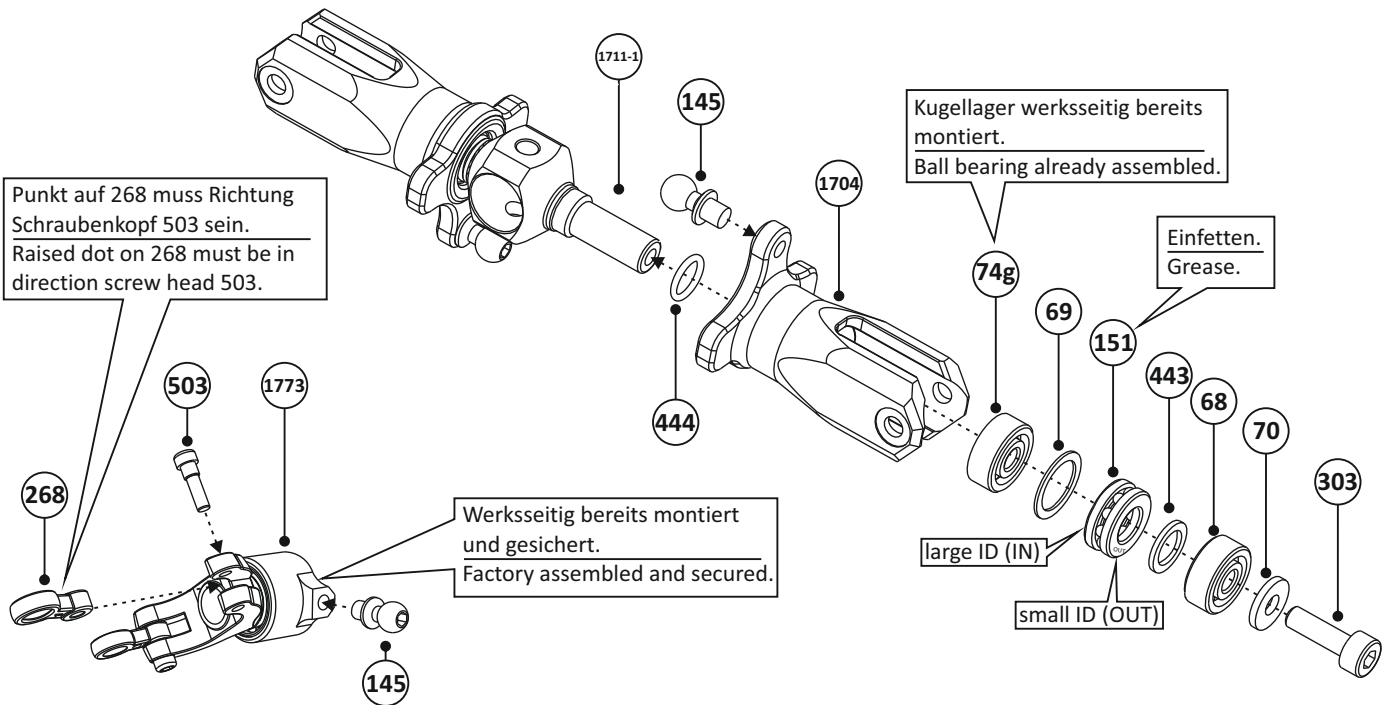

Normteile/Standard Parts

- | | | |
|-----------|--------------------------------|----|
| 33 | M4x4 Gewindestift
Set Screw | 1x |
|-----------|--------------------------------|----|

1:1



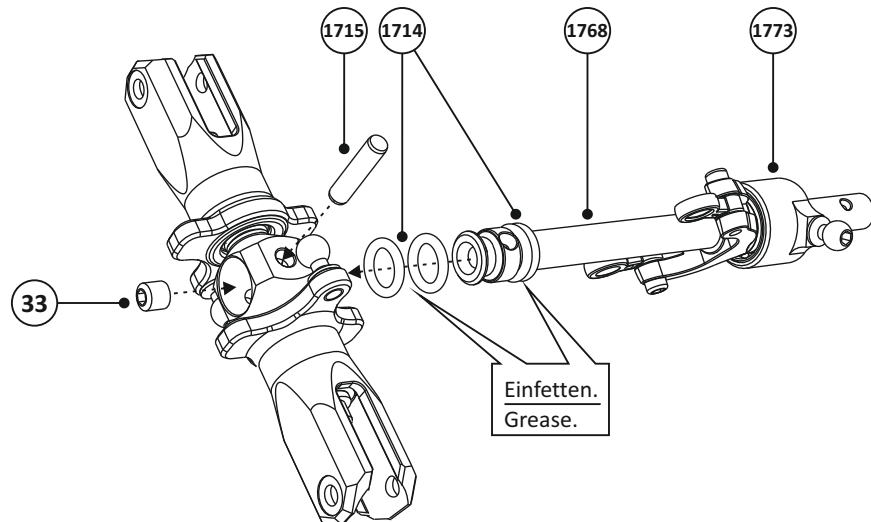





- | | | |
|-------------|------------------------------------|----|
| 1714 | Dämpfergummi
Damper Rubber | 4x |
| 1715 | 3x13 Bolzen
Bolt | 1x |
| 1768 | Heckrotorwelle
Tail Rotor Shaft | 1x |

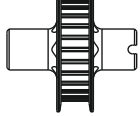
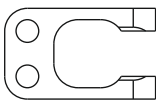

Einfetten.
Grease.

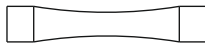

Normteile/Standard Parts

<p>1600 M3x12 Rundkopfschraube 1x Round Head Screw</p> 	<p>376 6x13x5 Flanschlager 2x Flanged Bearing</p> 	<p>1769 Heckantriebsrolle 26Z 1x Tail Drive Pulley 26T</p> 	<p>1772 Kugellagerhalter 1x Bearing Stand</p> 
<p>155 M3x6 Rundkopfschraube 6x Round Head Screw</p> 	<p>1802 3x8x3 Kugellager 2x Ball Bearing</p> 	<p>1770 Distanz Heckgehäuse 1x Spacer Tail Rotor Housing</p> 	<p>1767 Seitenplatte Heckgehäuse 1x Tail Rotor Housing Side Plates</p> 
<p>33 M4x4 Gewindestift 1x Set Screw</p> 	<p>1:1</p>		<p>1774 2x10 Bolzen 1x Pin</p> 

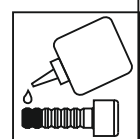
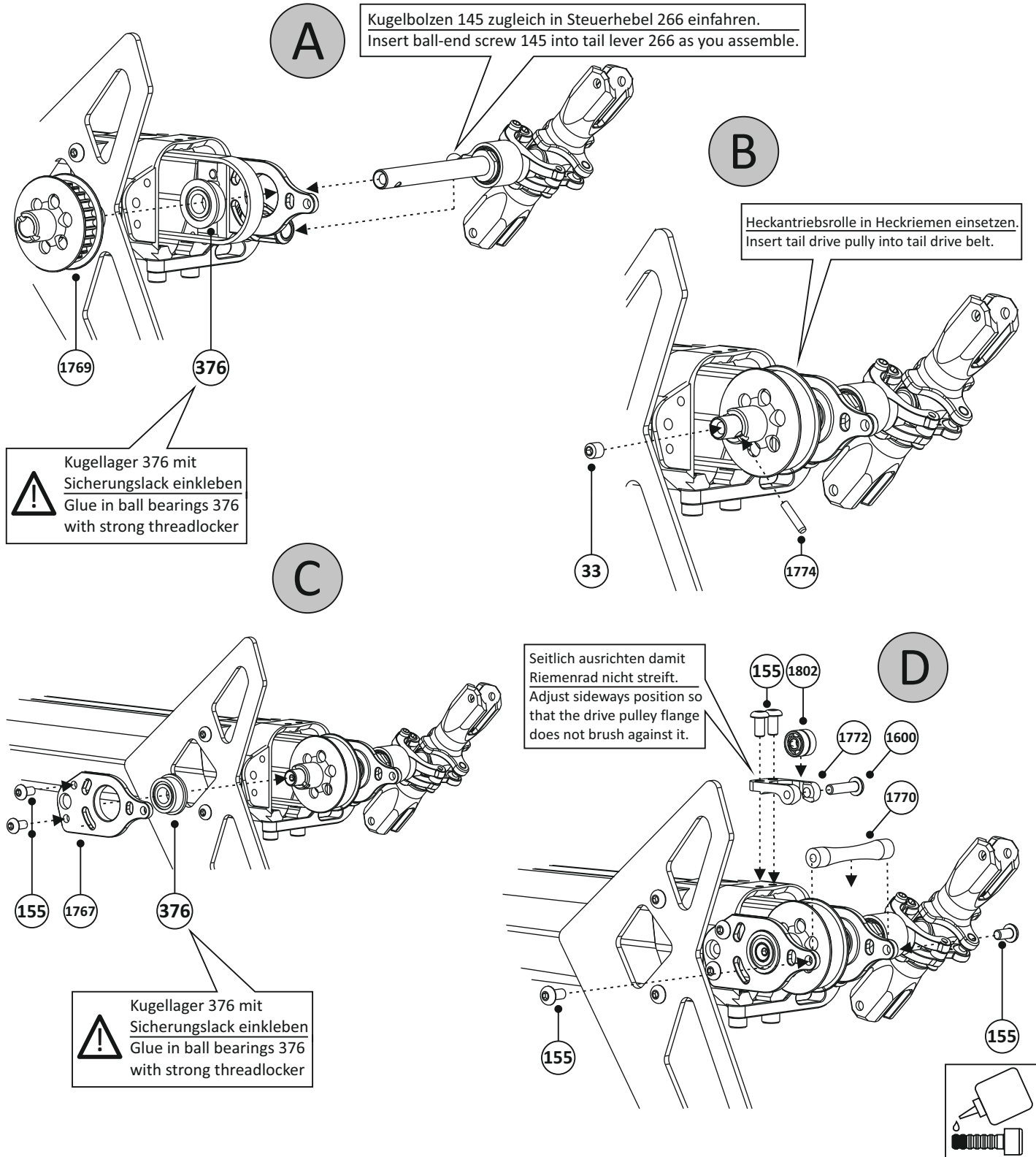

Normteile/Standard Parts

- 77 M3x16 Zylinderkopfschraube 2x
Socket Head Screw



1:1

! Heckriemen spannen: Riemen spannen, bis Riemenspanner vollständig am äusseren Anschlag ist, aber nicht überspannen!
Tighten tail drive belt: Tension the belt until the belt tensioner is touching the outer stop, but do not over tension!

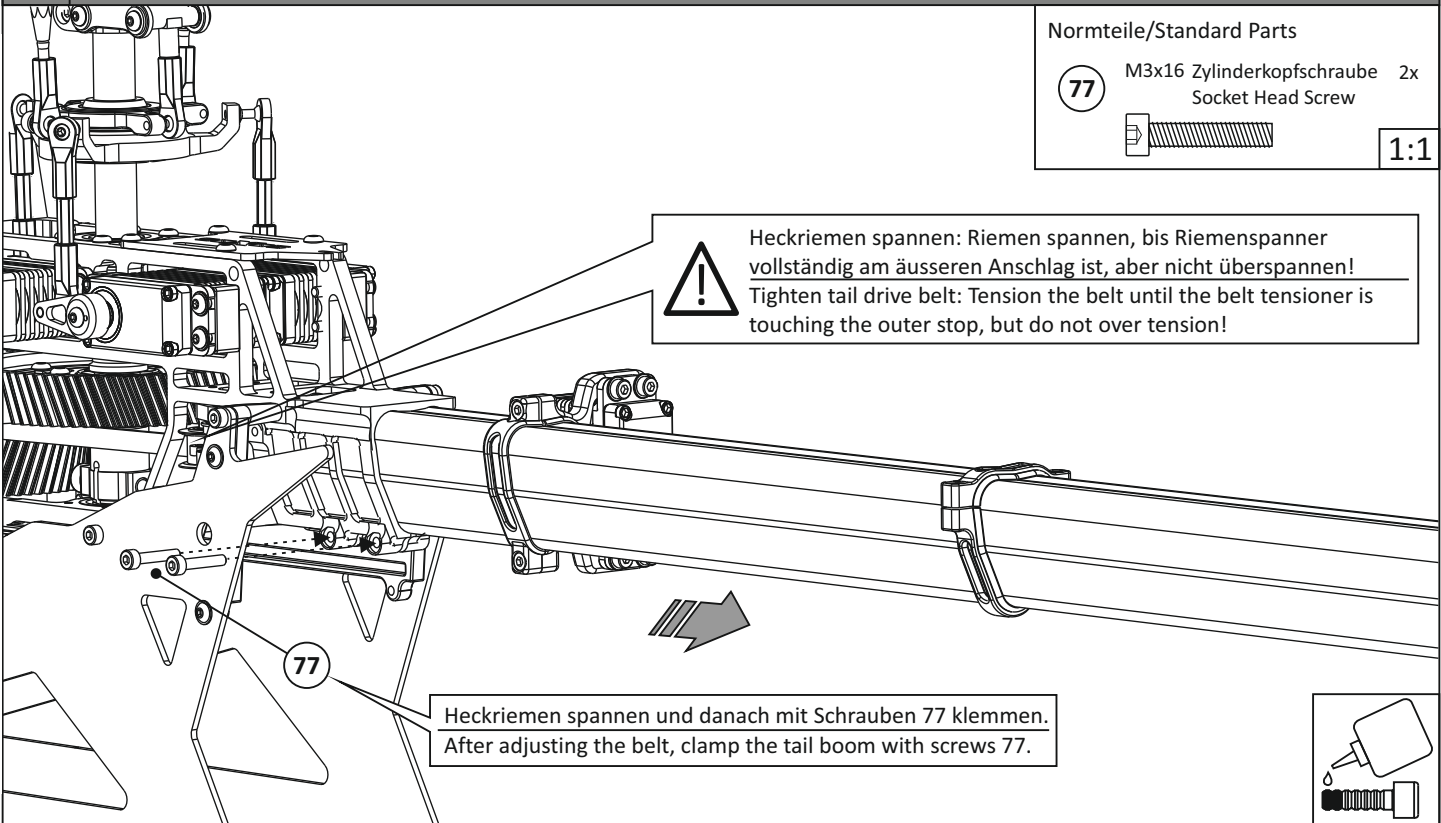

Heckriemen spannen und danach mit Schrauben 77 klemmen.
After adjusting the belt, clamp the tail boom with screws 77.

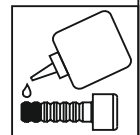

Normteile/Standard Parts

- 1684 M3x10 Rundkopfschraube 1x
Round Head Screw



- 354 M3x8 Rundkopfschraube 2x
Round Head Screw



- 54 3x7x3 Flanschlager 2x
Flanged Bearing



1:1

- 1805 Federhülse 1x
Spring Sleeve

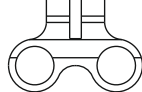

- 1695 Stift 2.5x15mm 2x
Pin



- 1783 Haubenhalter 1x
Canopy Holder Carbon



- 1806 Sicherheitshebel 1x
Safety Lever



- 1807 Stehbolzen 1x
Stud Bolt

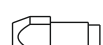

- 1808 Mutter 1x
Nut





- 1804 Druckfeder 2x
Pressure Spring

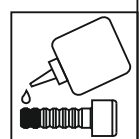
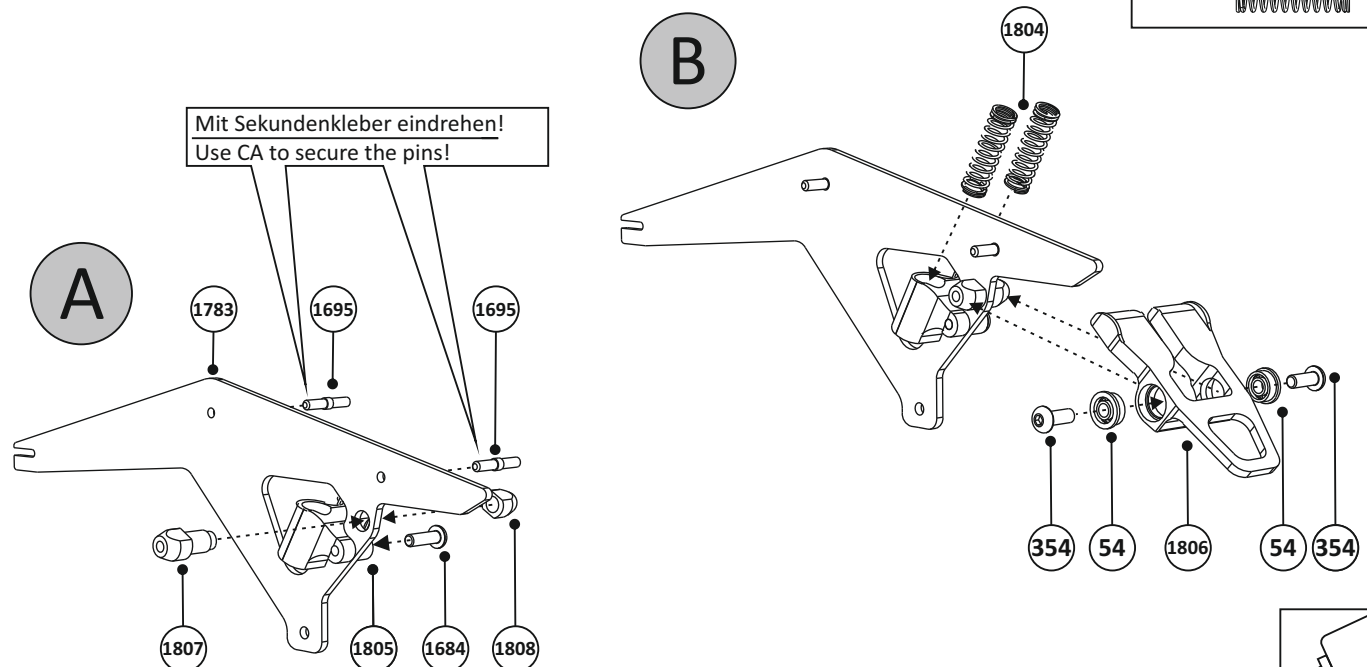

Mit Sekundenkleber eindrehen!
Use CA to secure the pins!

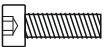

Normteile/Standard Parts

- 18 M3 Stopmutter Lock Nut 2x

- 71 M3x10 Zylinderkopfschraube 4x Socket Head Screw

- 303 M3x8 Zylinderkopfschraube 2x Socket Head Screw

1:1

1778 Halterklemme Holder Clamp 1x



1779 Halterklemme M3 Holder Clamp M3 1x



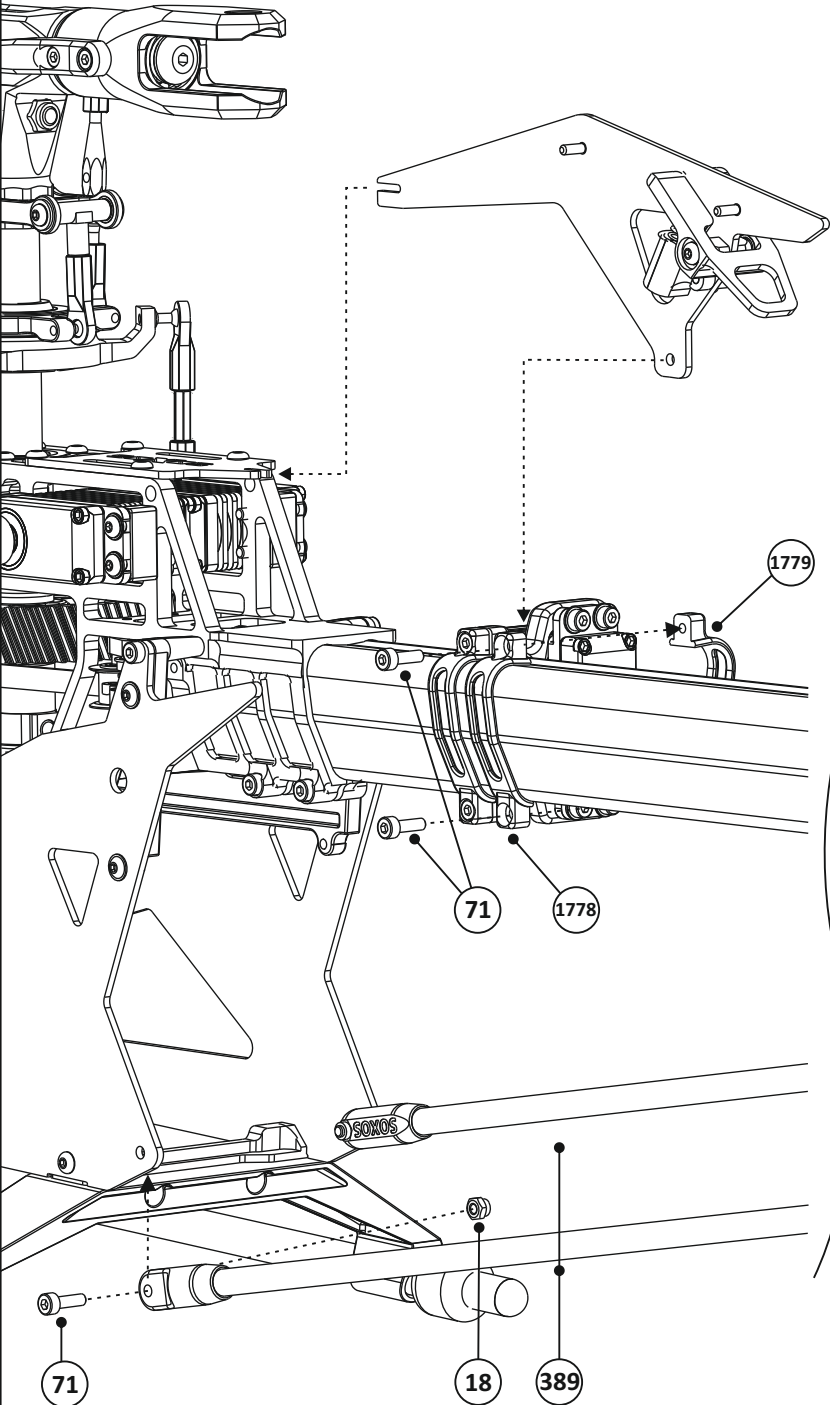
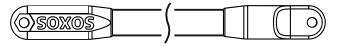

389 Heckstrebe Tail Brace Tube 2x

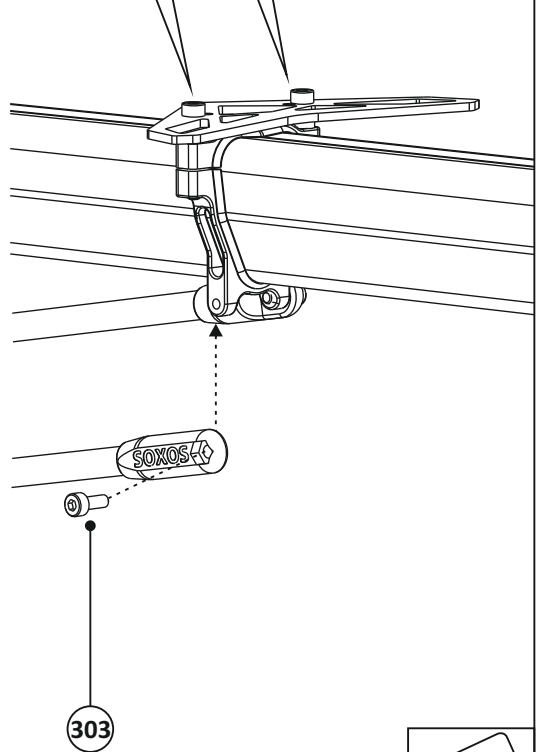

Mit diesen Schrauben erst nach Montage der Heckstreben anziehen.
Clamp with these screws after having installed the tail brace tubes.



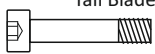
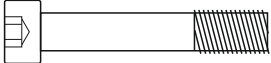

Normteile/Standard Parts

- | | |
|--|--|
| <p>510 M3x16 Heckrotorblattschraube 2x
Tail Blade Screw</p>  | <p>423 M5x30 Blatthalterschraube 2x
Blade Screw</p>  |
| <p>18 M3 Stoppmutter 2x
Lock Nut</p>  | <p>427 M5 Stoppmutter 2x
Lock Nut</p>  |

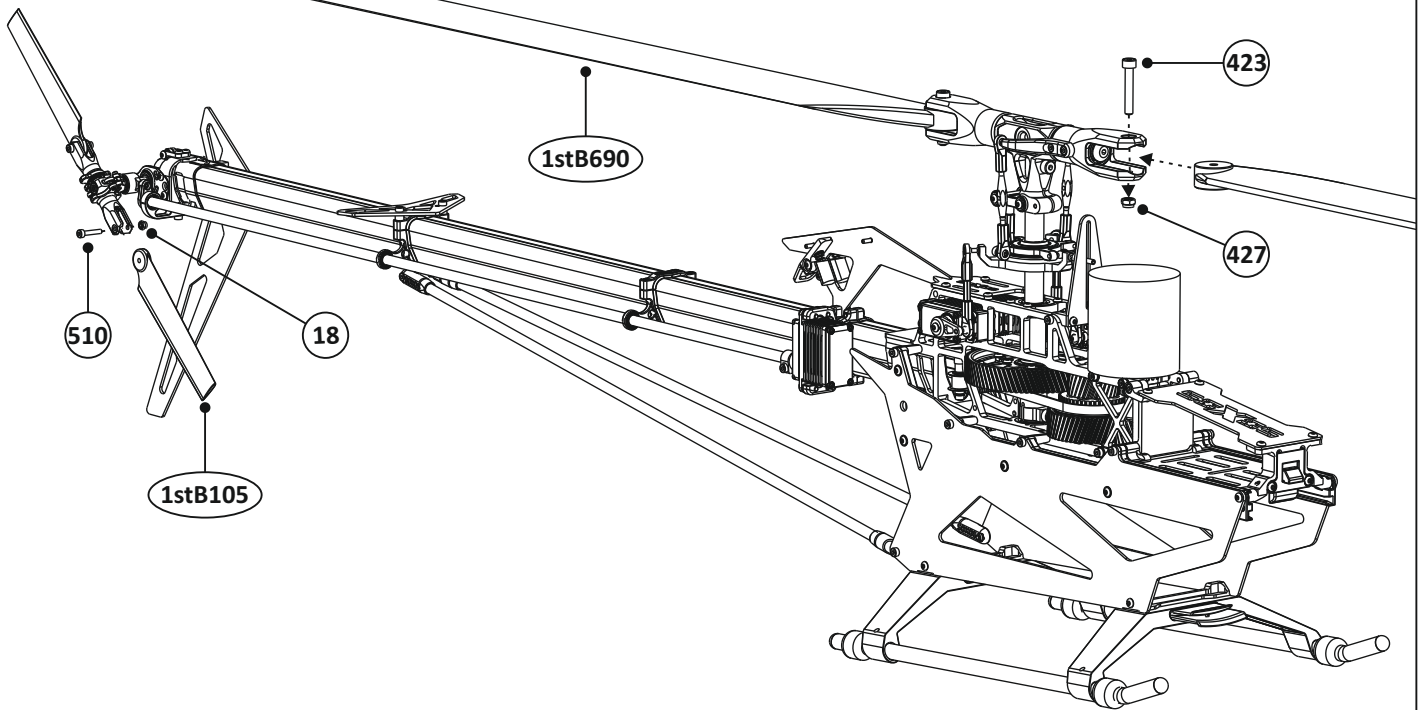
1:1

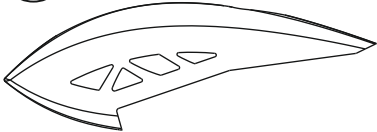

- | | |
|--|---|
| <p>259 C7.1 Haube Strike 7.1 1x
Canopy Strike 7.1</p>  | <p>517 Akkuplatte 1x
Battery Plate</p>  |
|--|---|

Justieren Sie die Balance des Helikopters mit der Positionierung des Akkus auf der Akkuplatte (inkl. Haube). Verwenden Sie das mitgelieferte Klettband, um den Akku zu sichern. Der Akku darf sich während des Fluges nicht verschieben.
Adjust the helicopter's balance with the position of the battery pack on the battery plate (incl. canopy). Use the supplied Velcro to secure the battery, the pack must not shift during flight.

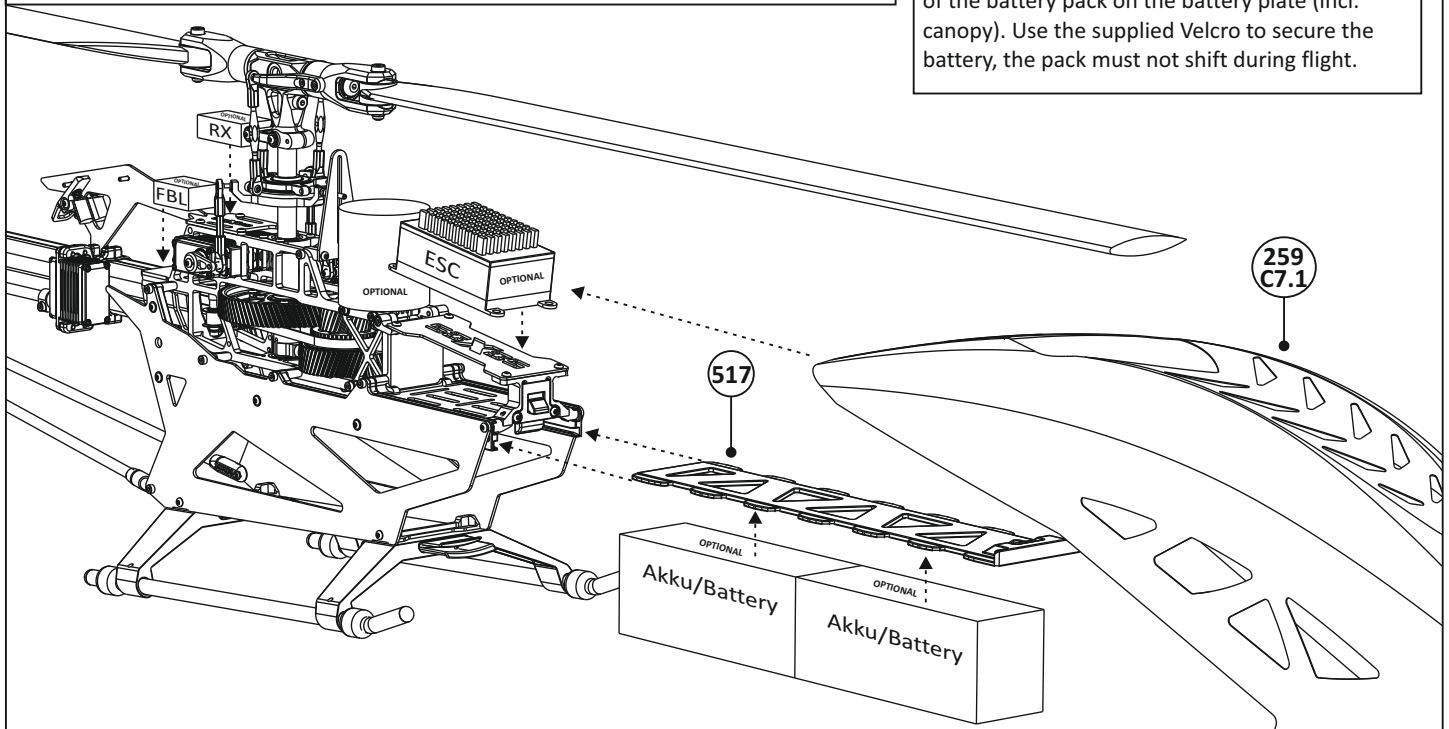

Für Ihre Notizen / For your notes:

Besuchen Sie unsere Homepage www.soxos-heli.com

Dort sind Ersatzteile wie Rotorblätter, Tuningteile, Werkzeuge, Motoren, Regler, Akkus und Gyros erhältlich.
Die neueste Version dieses Handbuchs können Sie downloaden.

Visit our homepage www.soxos-heli.com

Spare parts such as rotor blades, tuning parts, tools, motors, controllers, batteries and gyros are available there.
You can download the latest version of this manual.

