

# HELI PROFESSIONAL

swissengineering RC Helicopter

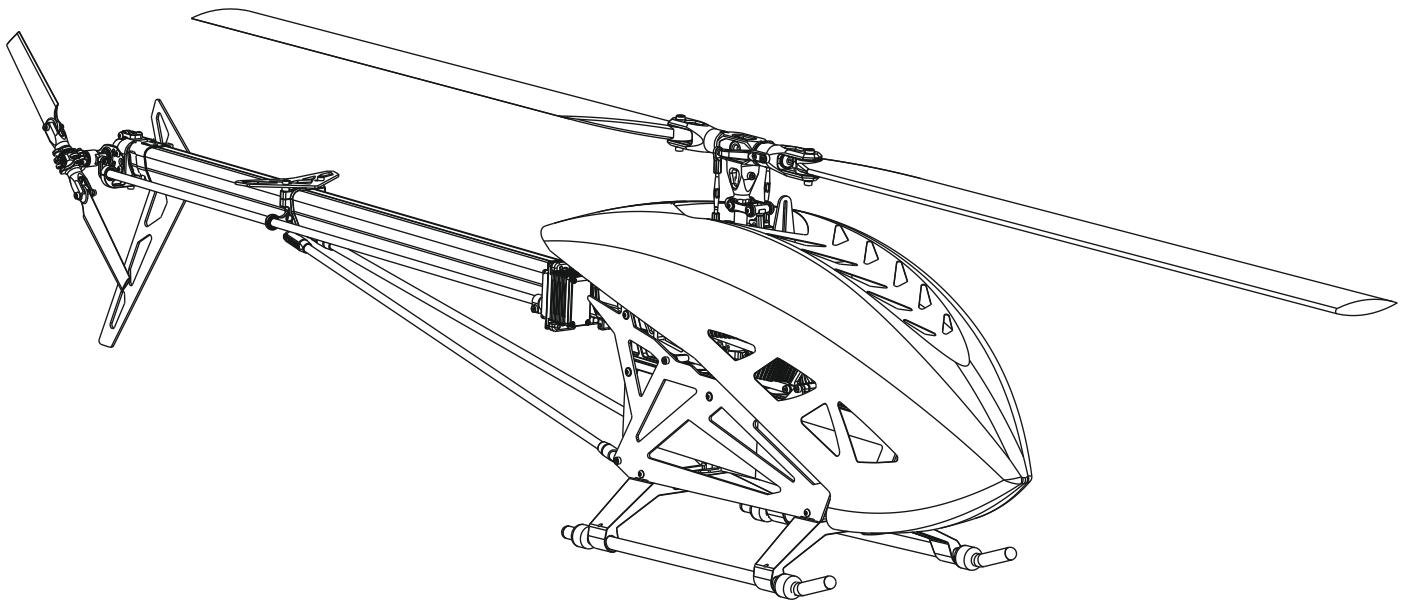

## SOX05 STRIKE 6.1

Bauanleitung und Handbuch V 1.1  
Assembly Instruction and Manual V 1.1

### INHALT/CONTENT

Technische Daten & Sicherheitshinweise/Specifications & Safety Instructions

Benötigtes Werkzeug & Allgemeine Hinweise/Required Tools & General Information

Bauanleitung und Handbuch/Assembly Instructions and Manual

Explosionszeichnung/Exploded view

## SEHR GEEHRTER KUNDE

**BESTEN DANK, DASS SIE SICH FÜR DEN soXos STRIKE 6.1 ENTSCIEDEN HABEN.**

Bevor Sie mit dem Zusammenbau oder der Inbetriebnahme beginnen,  
lesen Sie diese Anleitung bitte sorgfältig durch!

**DEAR CUSTOMER,**

**THANK YOU FOR CHOOSING THE soXos STRIKE 6.1 MODEL HELICOPTER.**

Before beginning with the assembly or operating the helicopter,  
please read this manual thoroughly!

### Technische Daten/Specifications

Hauptrotordurchmesser/Main Rotor Diameter:	ca. 1365mm (mit 600mm Blätter / with 600mm Blades)
Gewicht (ohne Komponenten und Blätter): Weight (without components and blades):	ca. 1795g
Antrieb: Setup:	6-12S
Länge/Length:	ca. 1240mm
Höhe/Height:	ca. 330mm
Übersetzung Hauptrotor: Gear ratio main rotor:	1:7.94 - 1:10.06 <b>Getriebe Übersetzungen:</b> Ritzel sind kompatibel für 6mm und 8mm Motorwellen <b>Gear Options:</b> Pinions are suitable for 6mm and 8mm motorshafts <b>15 Zähne/Ratio:</b> 10.06 <b>17 Zähne/Ratio:</b> 8.87 <b>19 Zähne/Ratio:</b> 7.94 <b>16 Zähne/Ratio:</b> 9.43 <b>18 Zähne/Ratio:</b> 8.38
Übersetzung Heckrotor: Gear ratio tail rotor:	1:5.05
Rotorblätter/Main blades:	580mm - 620mm
Heckrotorblätter/Tail blades:	95mm
Maximale Grösse des Motors:: Maximum size of the Motor:	Ø 63mm, Höhe 58mm, Motorwellenlänge von 20 - 56mm, 6 und 8mm Ø 63mm, height 58mm, motor shaft length from 20 - 56mm, 6 and 8mm
Maximale Abmessung des Antriebs-Akkus: Maximum dimension of the battery:	Breite 62mm, Höhe 68mm, Länge 350mm Width 62mm, Height 68mm, Length 350mm



#### Sicherheitshinweise:

Ein Modellhubschrauber ist kein Spielzeug, sondern ein sehr leistungsfähiges Flugmodell, das bei unsachgemäßer Bedienung und Wartung grossen Schaden an Mensch und Material verursachen kann. Kinder und Jugendliche sollten einen Modellhubschrauber nur unter Aufsicht eines sachkundigen Erwachsenen bedienen. Heli Professional kann für Haftungs- und Nachfolgeschäden von und mit Erzeugnissen aus dem Lieferprogramm nicht aufkommen und lehnt deshalb jegliche Haftung ab, da ein ordnungsgemäßer Betrieb oder Einsatz unsererseits nicht überwacht werden kann. Zudem bitten wir Sie, sich an die Bedienungsanleitung zu halten und nur Originalersatzteile von Heli Professional zu verwenden.



#### Safety Instructions:

A model helicopter is a very powerful flying device and not a toy. Disregarding our instructions, inappropriate use, and insufficient maintenance by persons lacking necessary competence may result in injuries for the user and can cause damage to the surroundings and to the model. Children and adolescents should operate a model helicopter only under supervision of an experienced adult. Heli Professional will not accept responsibility for any damage caused by their products and rejects any liability as we are not in a position to supervise proper operation, handling, and maintenance by the user. Furthermore, we ask you to follow our operating and assembly instructions carefully and to use only original Heli Professional parts.

## Benötigtes Werkzeug/Required Tools

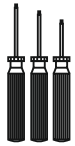

Innensechskantschlüssel  
Hexagon Socket Wrenches  
SW 1.5/2/2.5/3



Schraubensicherungslack, mittelfest und fest  
Threadlocker, medium and strong

Sekundenkleber  
CA (Cyanoacrylic Instant Adhesive)

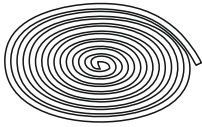
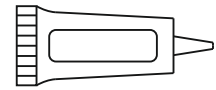

Schnur ca. 2m  
String



Fett  
Grease

Gabelschlüssel 5.5mm  
Flat Wrench

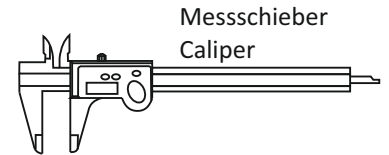
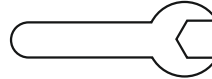

Messschieber  
Caliper

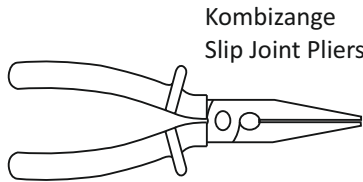

Kombizange  
Slip Joint Pliers

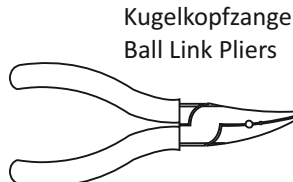

Kugelpkopzange  
Ball Link Pliers

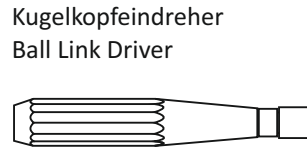

Kugelpkopfeindreher  
Ball Link Driver

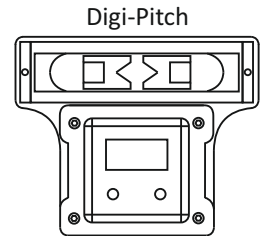

Digi-Pitch

## Allgemeine Hinweise/General Information

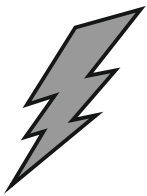

**WICHTIG:** Bevor Sie mit dem Zusammenbau oder der Inbetriebnahme beginnen, lesen Sie diese Anleitung bitte sorgfältig durch!

**IMPORTANT:** Before beginning with the assembly or operating the helicopter, please read this manual thoroughly!

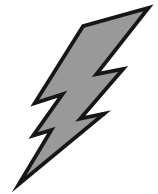

- Es sind keine elektronischen Bauteile, wie z.B. Servos, etc. im Lieferumfang enthalten.
- The kit does not include any electronic components such as servos, etc.

- Grundsätzlich muss jede Schraube entfettet und mit Sicherungslack eingeklebt werden. Auch bereits vormontierte Teile müssen diesbezüglich kontrolliert werden. Das rechts abgebildete Symbol soll Sie während des Zusammenbaus daran erinnern. Kugellager werden NICHT eingeklebt, ausser es wird darauf hingewiesen.
- In general, every screw must be cleaned and secured with threadlocker. Also, check preassembled parts regarding this. The symbol on the right-hand side is supposed to remind you while going through the assembly process. Ball bearings must NOT be secured with threadlocker except where noted.

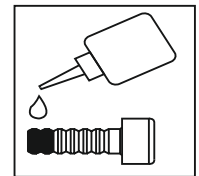

**1:1**

- Die in den Bauabschnitten mit diesem Symbol abgebildeten Schrauben, etc. sind in Originalgrösse dargestellt.
- The screws and all other parts depicted with this symbol in the assembly steps are actual-size drawings.

- Achten Sie auf die Freigängigkeit aller verbauten Kugellager und Drucklager.
- Check all ball bearings and thrust bearings for ease of movement.

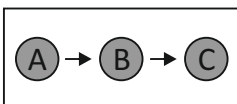
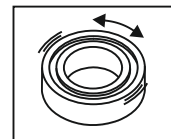

- Montieren Sie die Bauteile in der angegebenen Reihenfolge.
- Assemble the parts in the specified order.

- Wiederholen Sie den Montageschritt so oft wie angegeben (hier: zwei Mal).
- Repeat the assembly step as often as specified (here: twice).

**2x**

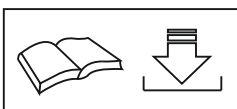



- Handbücher und Bauanleitungen für Tuningteile sind direkt von der Webseite zu beziehen.
- Manuals and assembly instructions for tuning parts are to be downloaded directly from the website. [www.soxos-heli.com](http://www.soxos-heli.com)

Normteile/Standard Parts

- 9** 3x7.5 Linsenkopf Treibschraube 8x  
Flanged Round Head Self  
Tapping Screw

- 8** 3x12 Treibschraube  
Self Tapping Screw 2x



- 92** M3x6 Gewindestift  
Set Screw 4x



- 354** M3x8 Rundkopfschraube  
Round Head Screw 8x



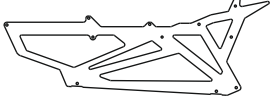

1:1

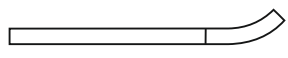
- 1979** Carbon Seitenplatte  
Side Plate Carbon 2x



- 436** Kufenrohr  
Skid Pipe 2x



- 464** Kufengummi  
Skid Rubber 4x



- 275** Akkuschiene rechts  
Battery Rail Plate right 1x

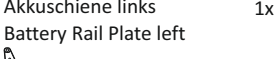

- 356** Endkappe Kufenrohr 4x  
Skid Pipe Cap



- 1664** Kufenhalterung 2x  
Landing Skid Holder

- 276** Akkuschiene links  
Battery Rail Plate left 1x

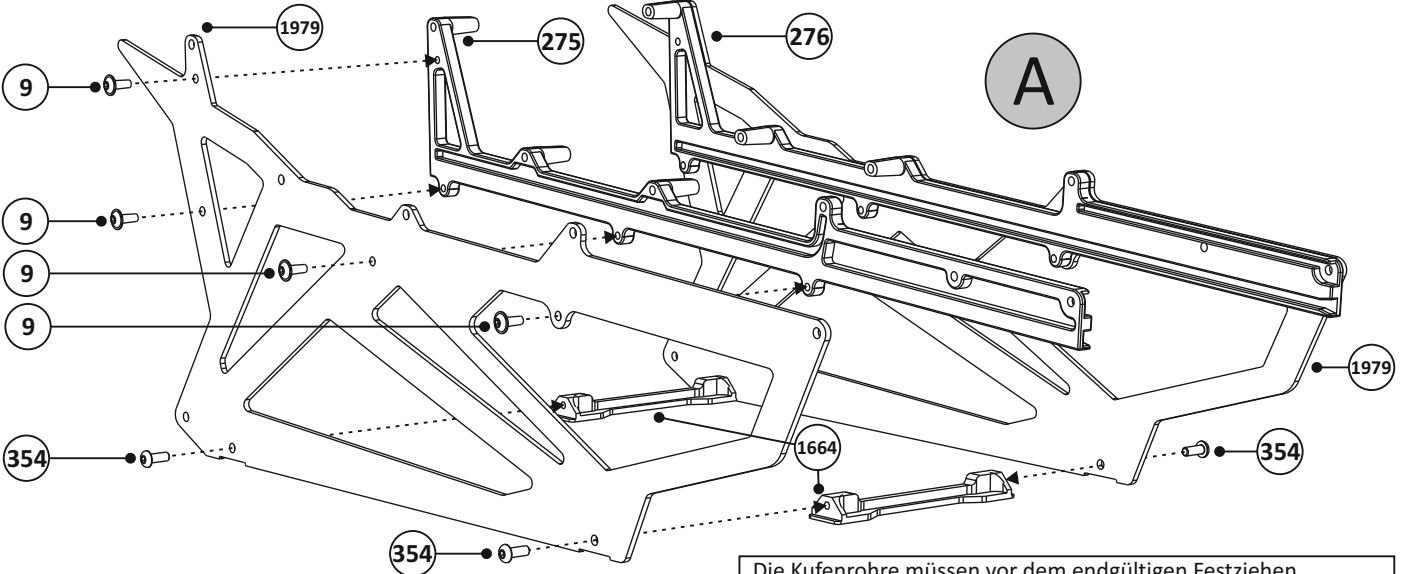

- 1624** Landegestell Weiss 2x  
Landing Skid White

- 1625** Haubenhalterung 1x  
Canopy Support  
landing skid



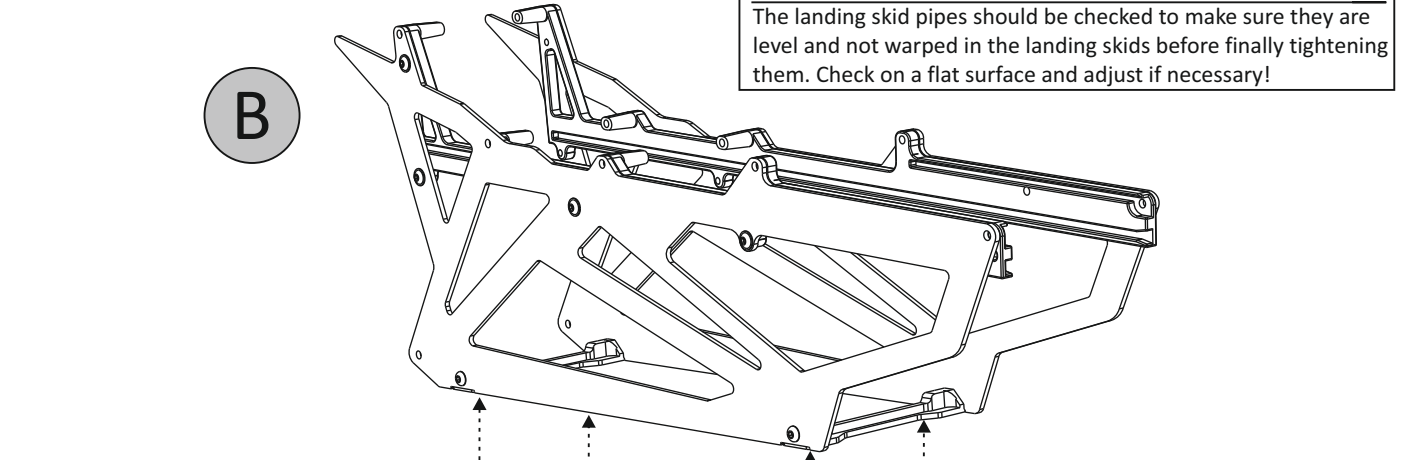

Die Kufenrohre müssen vor dem endgültigen Festziehen plan und ohne Spannungen im Landegestell aufliegen.  
Auf einer ebenen Unterlage überprüfen und ggf. justieren!  
The landing skid pipes should be checked to make sure they are level and not warped in the landing skids before finally tightening them. Check on a flat surface and adjust if necessary!



Endkappe Kufenrohr mit Sekundenkleber einkleben!  
Use CA to secure the Skid Pipe Cap!

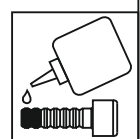
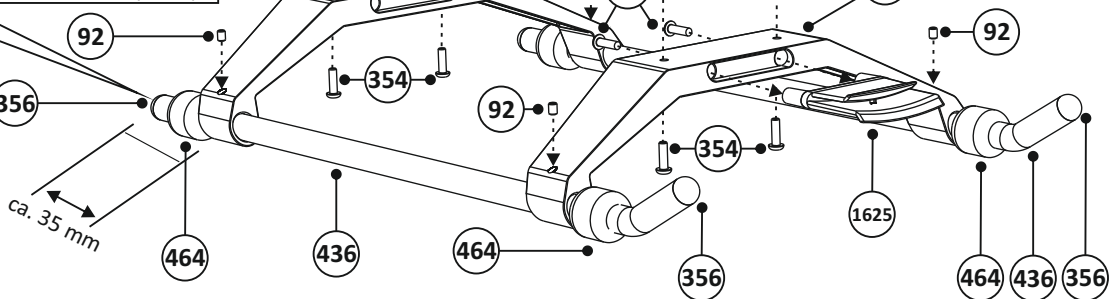

Normteile/Standard Parts

**142** M3x22 Schraube  
Hex Socket Screw 2x



**105** M3x18 Schraube  
Hex Socket Screw 1x

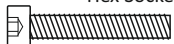

**155** M3x6 Rundkopfschraube  
Round Head Screw 6x



**1705** 3x8x3 Flanschlager  
Flanged Bearing 6x



**1706** Distanzhülse  
Distance Sleeve 2x

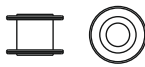

**1741** Feder U-Scheibe  
Spring Washer 1x



**1738** Distanzhülse  
Distance Sleeve 1x

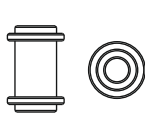

**1823** 10x24x6 Flanschlager  
Flanged Bearing 1x

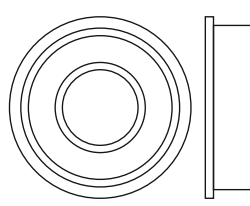

1:1

**1777** Adapter Platte  
Adapter Plate 1x

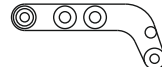

**1766** Rahmen  
Main Frame 1x

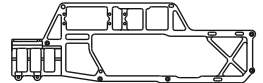

**1680-01** Heckriemenführung  
Tail Belt Guide 2x



**1742** Zugfeder  
Extension Spring 1x



**1744** Klemmhebel  
Gripping Lever 1x



2x **A**

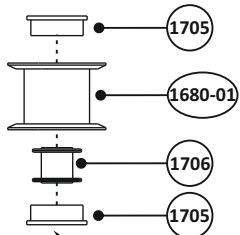

**B**

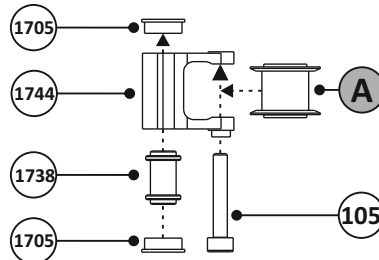

**C**

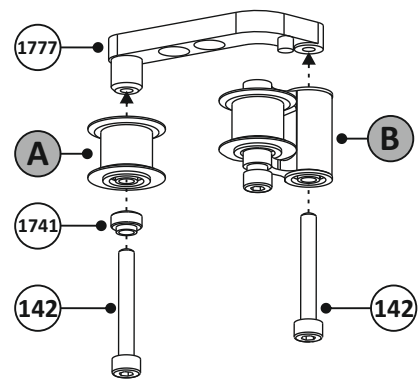

**!** Alle Kugellager in der Baugruppe A mit Sicherungslack einkleben!  
Glue all ball bearings in the assembly A with strong threadlocker!

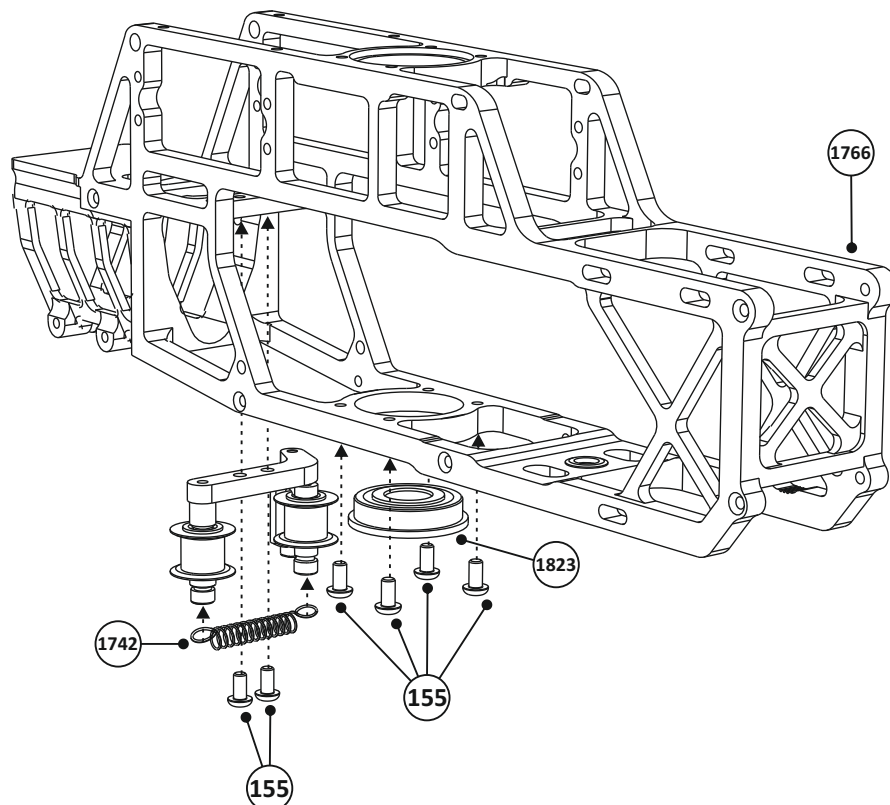

Normteile/Standard Parts

- 354 M3x8 Rundkopfschraube 12x Round Head Screw

1:1

- 1641-1 Hauptzahnrad Nabe 1x Main Drive Hub

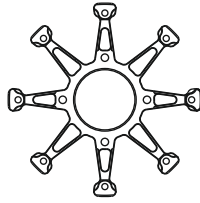

- 1643 Hauptzahnrad 81Z 1x Main Drive Gear 81T

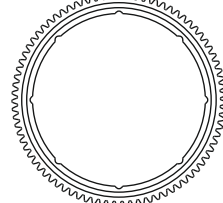

- 1822 Flanschmuffe 1x Flanged Sleeve

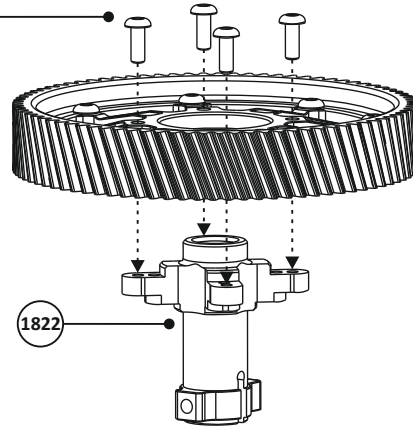
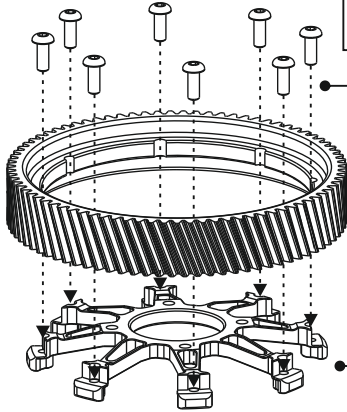
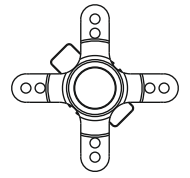

**!** Schrauben erst leicht eindrehen, danach gleichmässig anziehen!  
First lightly seat the screws, then tighten them evenly!

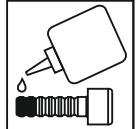

Normteile/Standard Parts

- 155 M3x6 Rundkopfschraube 4x Round Head Screw

- 487 M3x25 Spezialschraube 1x Special Screw

- 1823 10x24x6 Flanschlager 1x Flanged Bearing

1:1

- 1986-06 Heckriemen 1x Tail Drive Belt

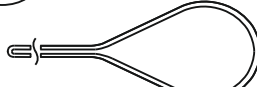

- 1821 Hauptrotorwelle 1x Main Shaft

- 331 Distanzhülse 1x Hauptrotorwelle Distance Sleeve Main Shaft

- 1594 10x16x0.1 Passscheiben 2x Distance Washer

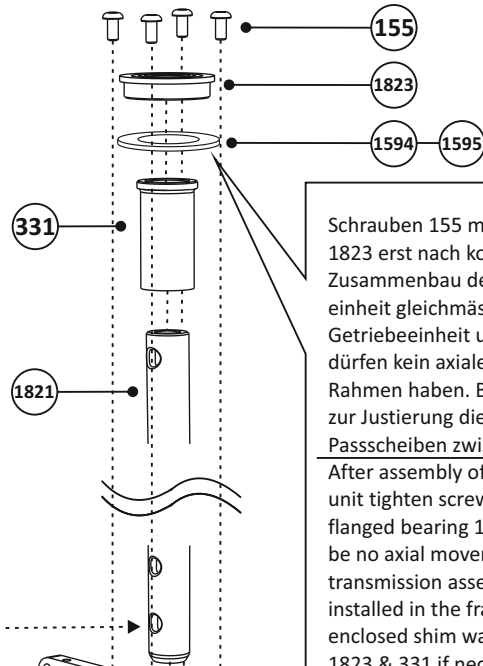

- 1595 10x16x0.2 Passscheiben 2x Distance Washer



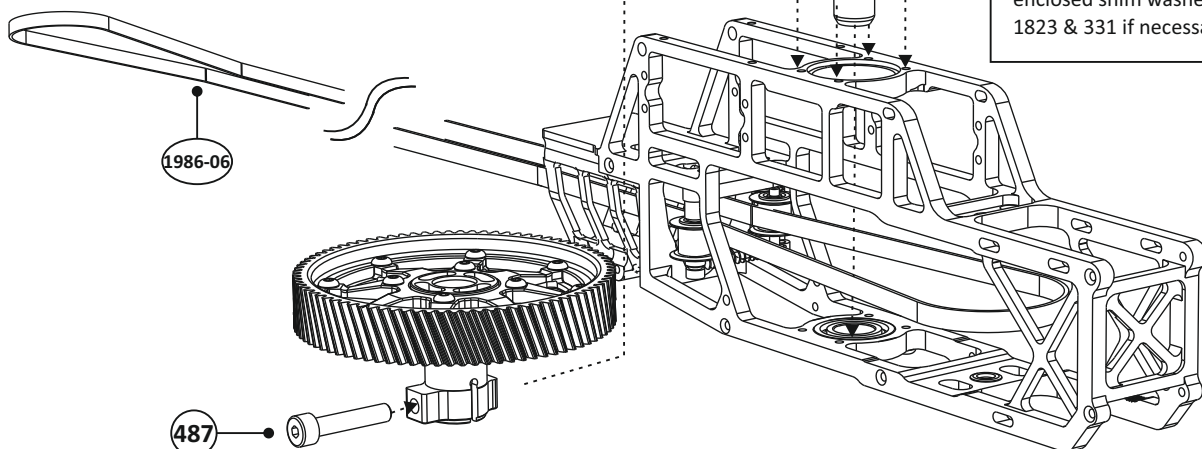

**!** Schrauben 155 mit Flanschlager 1823 erst nach komplettem Zusammenbau der Getriebeeinheit gleichmässig anziehen. Getriebeeinheit und Rotorwelle dürfen kein axiales Spiel im Rahmen haben. Benutzen Sie ggf. zur Justierung die beiliegenden Passscheiben zwischen 1823 & 331. After assembly of the transmission unit tighten screws 155 on the flanged bearing 1823. There must be no axial movement of the transmission assembly when installed in the frame. Use the enclosed shim washers between 1823 & 331 if necessary.

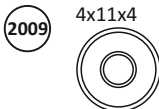
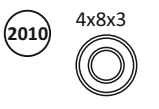

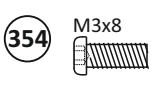
Normteile/Standard Parts

- 
2009 4x11x4 Kugellager / Ball Bearing 1x
- 
2010 4x8x3 Kugellager / Ball Bearing 3x
- 
303 M3x8 Zylinderkopfschraube / Socket Head Screw 4x
- 
354 M3x8 Rundkopfschraube / Round Head Screw 6x

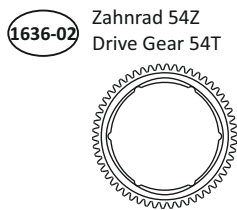
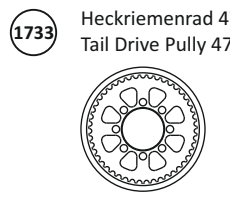
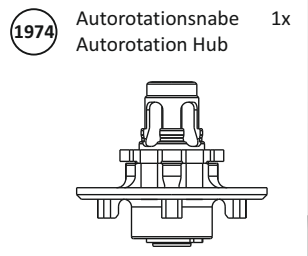
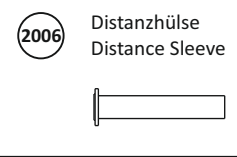
1:1

- 
1636-02 Zahnrad 54Z / Drive Gear 54T 1x
- 
1733 Heckriemenrad 47Z / Tail Drive Pully 47T 1x
- 
1974 Autorotationsnabe / Autorotation Hub 1x
- 
2006 Distanzhülse / Distance Sleeve 1x
- 
2012 Zahnrad 29Z / Drive Gear 29T 1x

Werkseitig bereits montiert und gesichert.  
Factory assembled and secured.

 Schrauben erst leicht eindrehen, danach gleichmässig anziehen!  
First lightly seat the screws, then tighten them evenly!

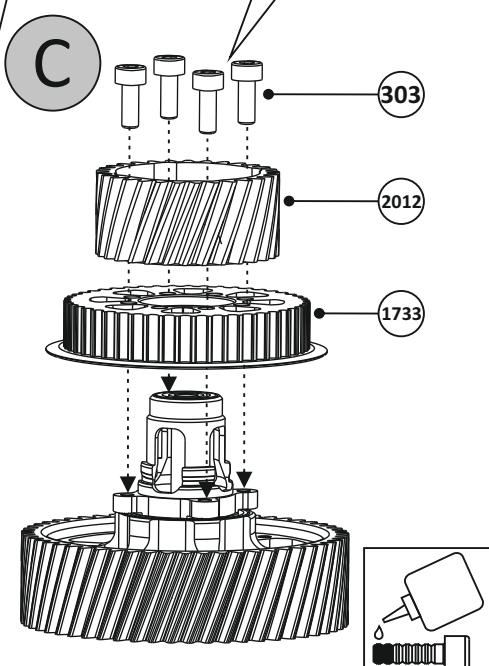
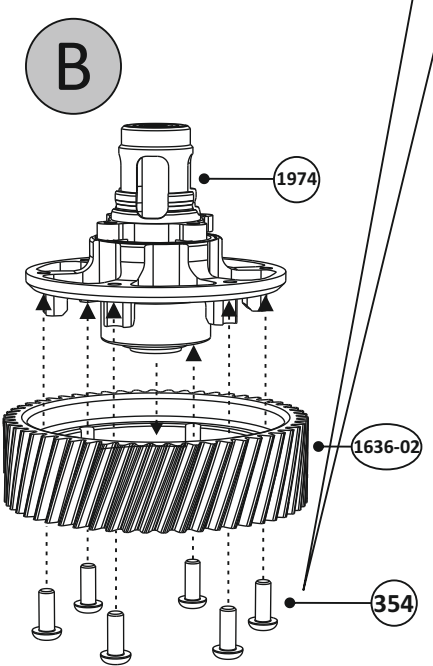
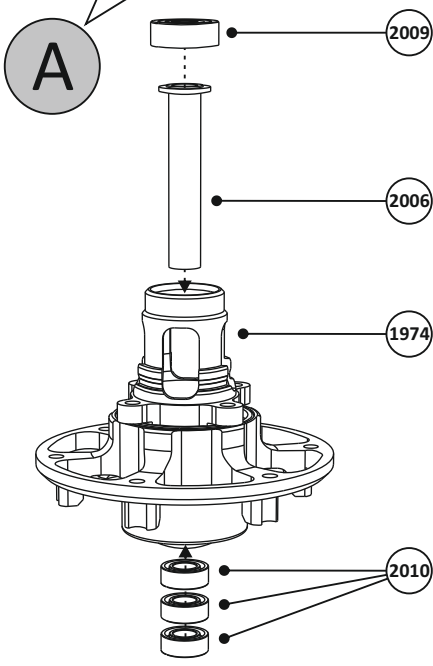

Normteile/Standard Parts

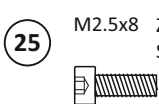
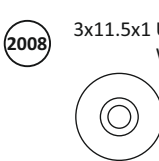
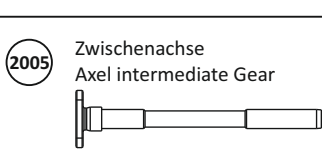
- 
25 M2.5x8 Zylinderkopfschraube / Socket Head Screw 1x
- 
2008 3x11.5x1 U-Scheibe / Washer 1x
- 
2005 Zwischenachse / Axel intermediate Gear 1x

1:1

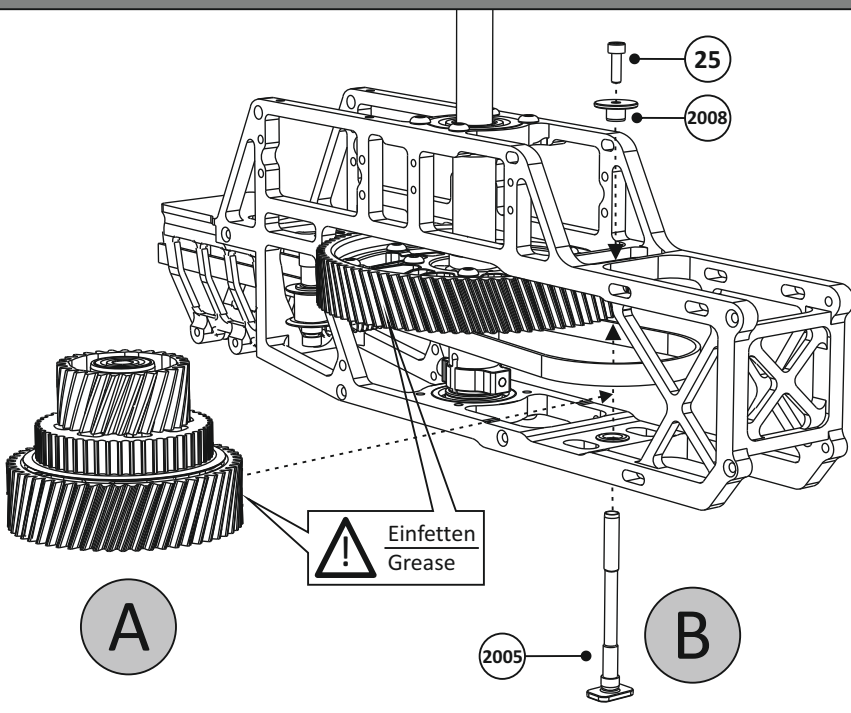

 Einfetten / Grease

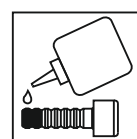

Normteile/Standard Parts

55 M3x25 Zylinderkopfschraube 6x  
Socket Head Screw

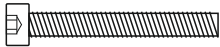

1:1

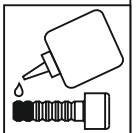
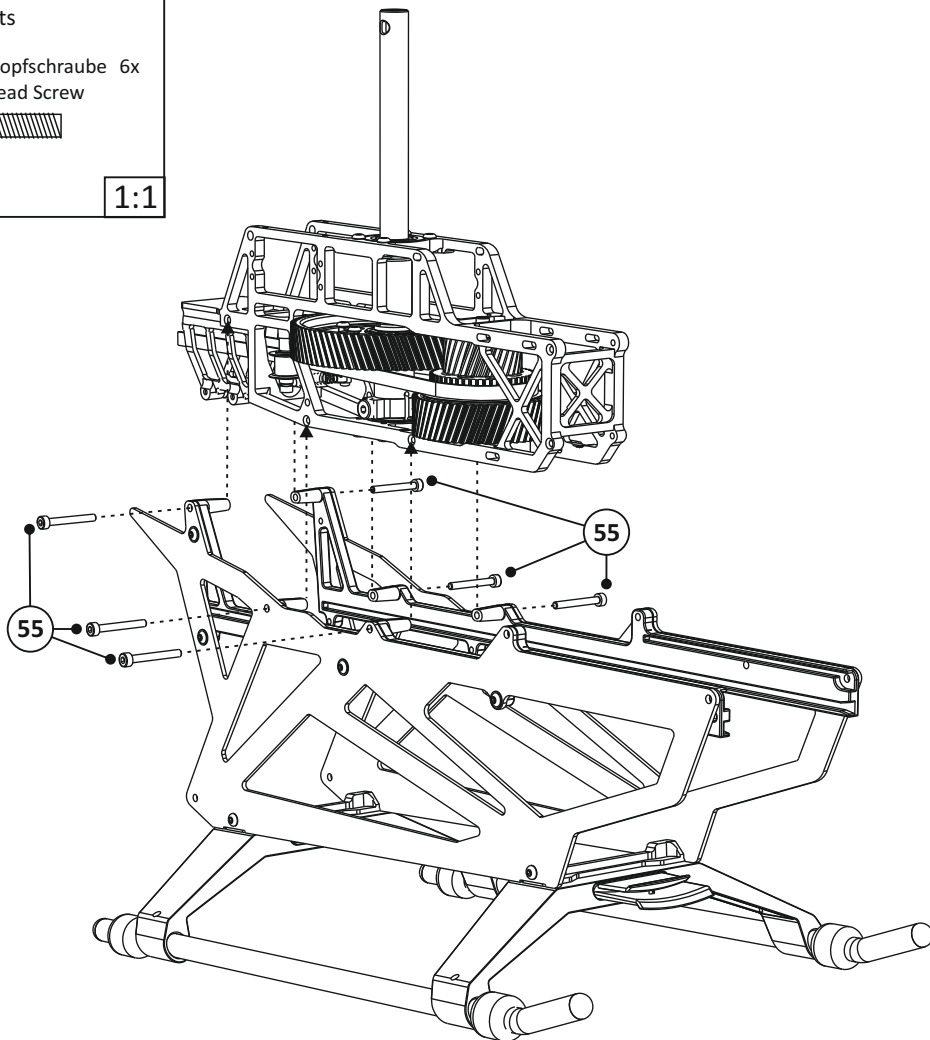

Normteile/Standard Parts

1684 M3x10 Rundkopfschraube 2x  
Round Head Screw



155 M3x6 Rundkopfschraube 8x  
Round Head Screw



1:1

1551 Vorbaudeckel  
Porch Plate Top 1x

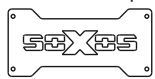

1552 Vorbauboden  
Porch Plate Bottom 1x

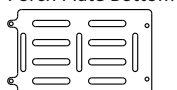

546 Bolzen Halterplatte  
Bolt Box Plate 1x

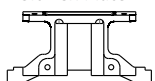

547 Halterung  
Porch Holder 1x

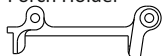

318 Verschluss  
Latch 1x



350 Druckfeder  
Pressure Spring 1x



319 Verschlussgehäuse  
Bolt Box 1x

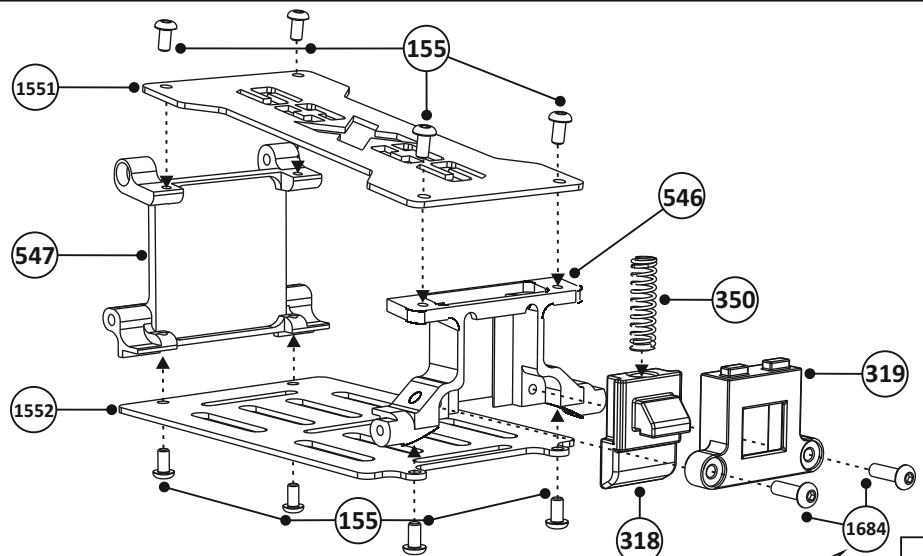

**!** Schraube 1684 nicht zu stark anziehen und auf Leichtgängigkeit des Verschlusses 318 achten!  
Do not overtighten screw 1684 to keep smooth movement of latch 318!





## Normteile/Standard Parts

55 M3x25 Zylinderkopfschraube 2x  
Socket Head Screw

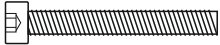

71 M3x10 Zylinderkopfschraube 2x  
Socket Head Screw

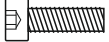





1684 M3x10 Rundkopfschraube 2x  
Round Head Screw

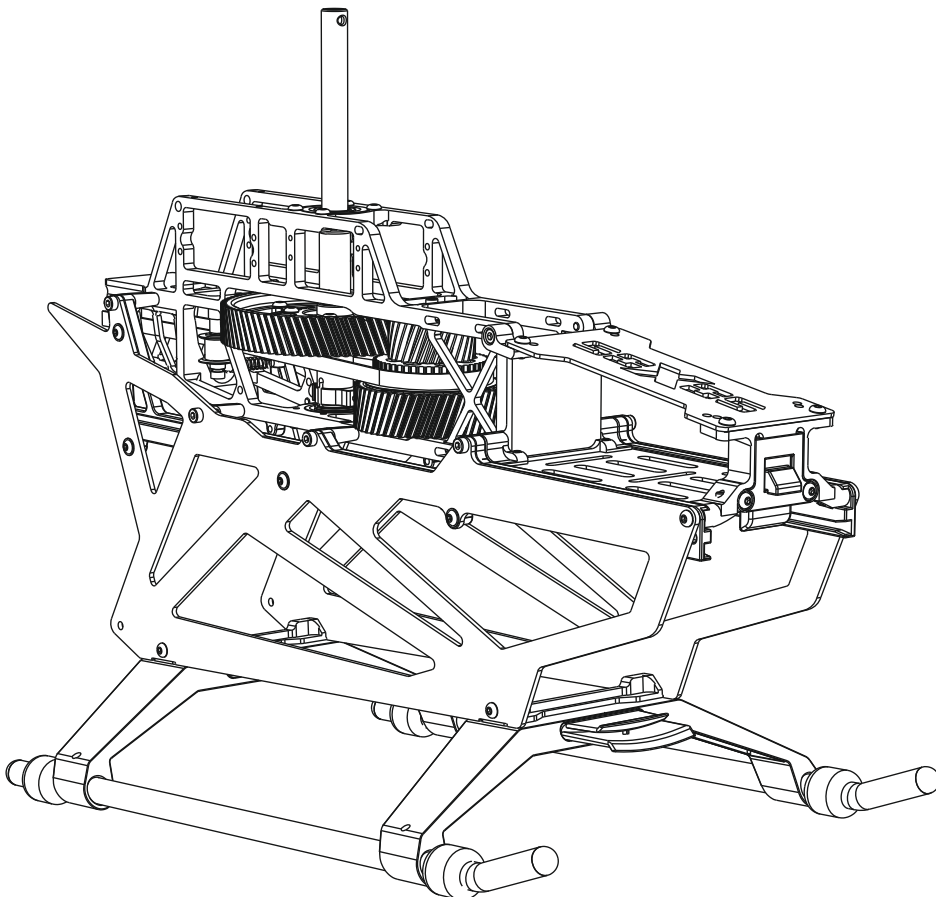
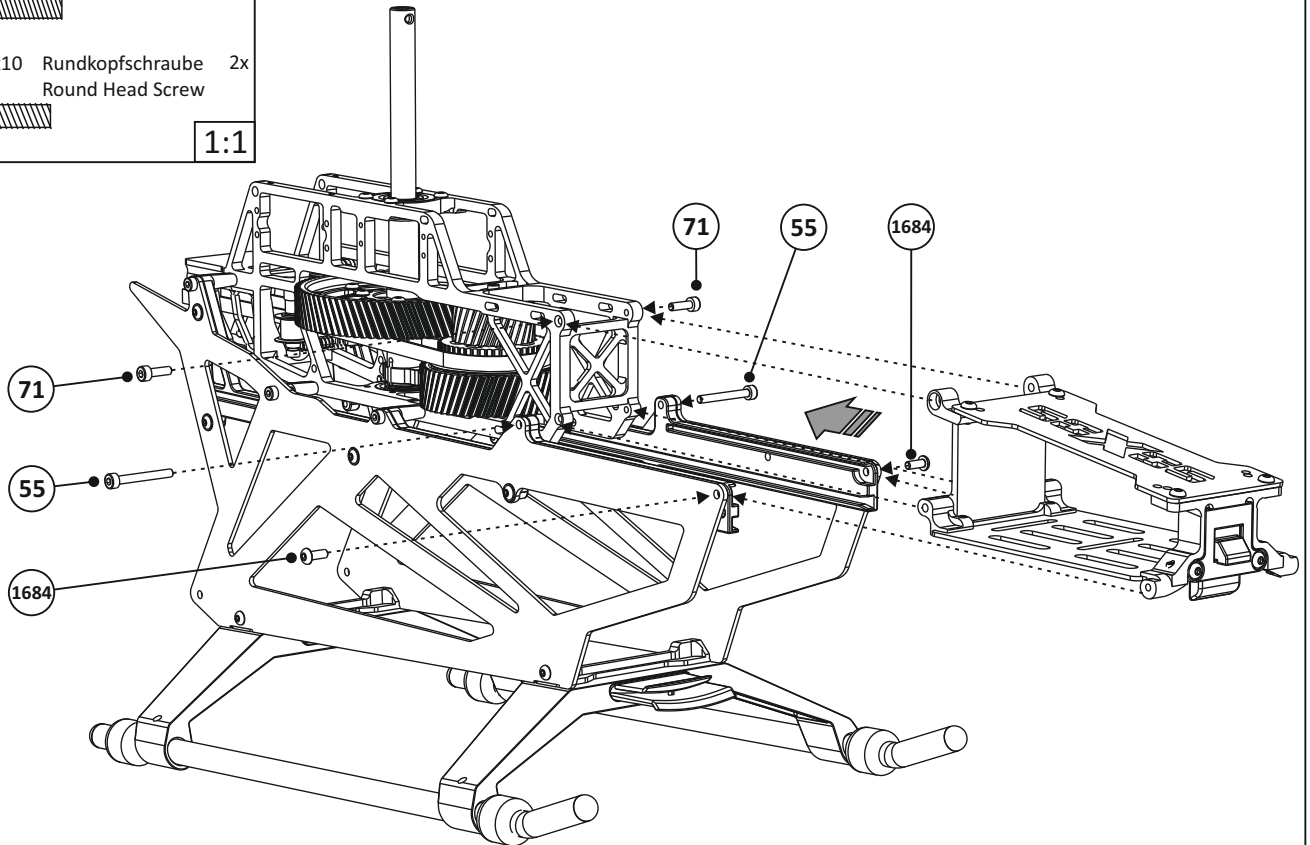

1:1

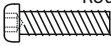

Normteile/Standard Parts

- 1600 M3x12 Rundkopfschraube 4x  
 Round Head Screw  

- 1601 M3x20 Rundkopfschraube 8x  
 Round Head Screw  

- 11 M3 U-Scheibe 12x  
 Washer  

- 145 M3x4.5 Kugelpfopf 3x  
 Ball End Screw  

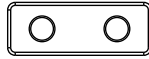
- 354 M3x8 Rundkopfschraube 3x  
 Round Head Screw  

1:1

137-01

Servodistanz 7 mm 4x  
 Servo Distance Block



1665

Servodistanz 9.5 mm 4x  
 Servo Distance Block



41

Servoplättchen 10x  
 Servo Mounting Plates

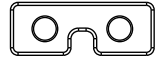

1659

Servo Einsatz 23Z,24Z,25Z,25Z/8  
 Insert Servo 23T,24T,25T,25T/8



1797

Servoarm 3x  
 Servo Horn

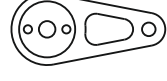

Je nach verwendeten Servos müssen Sie die unterschiedliche Einbautiefe der Servos durch die Verwendung des 7mm oder 9,5mm Servodistanzblocks ausgleichen. Für weitere Anpassungen können Sie die dünneren Servo-Montageplatten verwenden. Wichtig: Verwenden Sie auf jeder Seite die gleiche Anzahl an Servo-Montageplatten. Alle Teile auf Freigängigkeit prüfen. Die Servos dürfen sich nicht in der Mitte des Rahmens berühren. Die Schubstangen sollten so senkrecht wie möglich zur Taumelscheibe sein.

Je nach Art des verbauten Servos können die Schrauben aus der Rahmeninnenseite herausragen.

Depending on the servos used, you must compensate the differing mounting depth of the servos by using the 7mm or 9.5mm servo distance block. For more adjustment you can use the thinner servo mounting plates. Important: Use the same amount of servo mounting plates on each side. Check all parts for ease of movement. The servos must not touch each other in the middle of the frame but the servo to swash links should be as close to vertical as possible.

Depending on the type of servo installed, the screws may protrude from the inside of the frame.

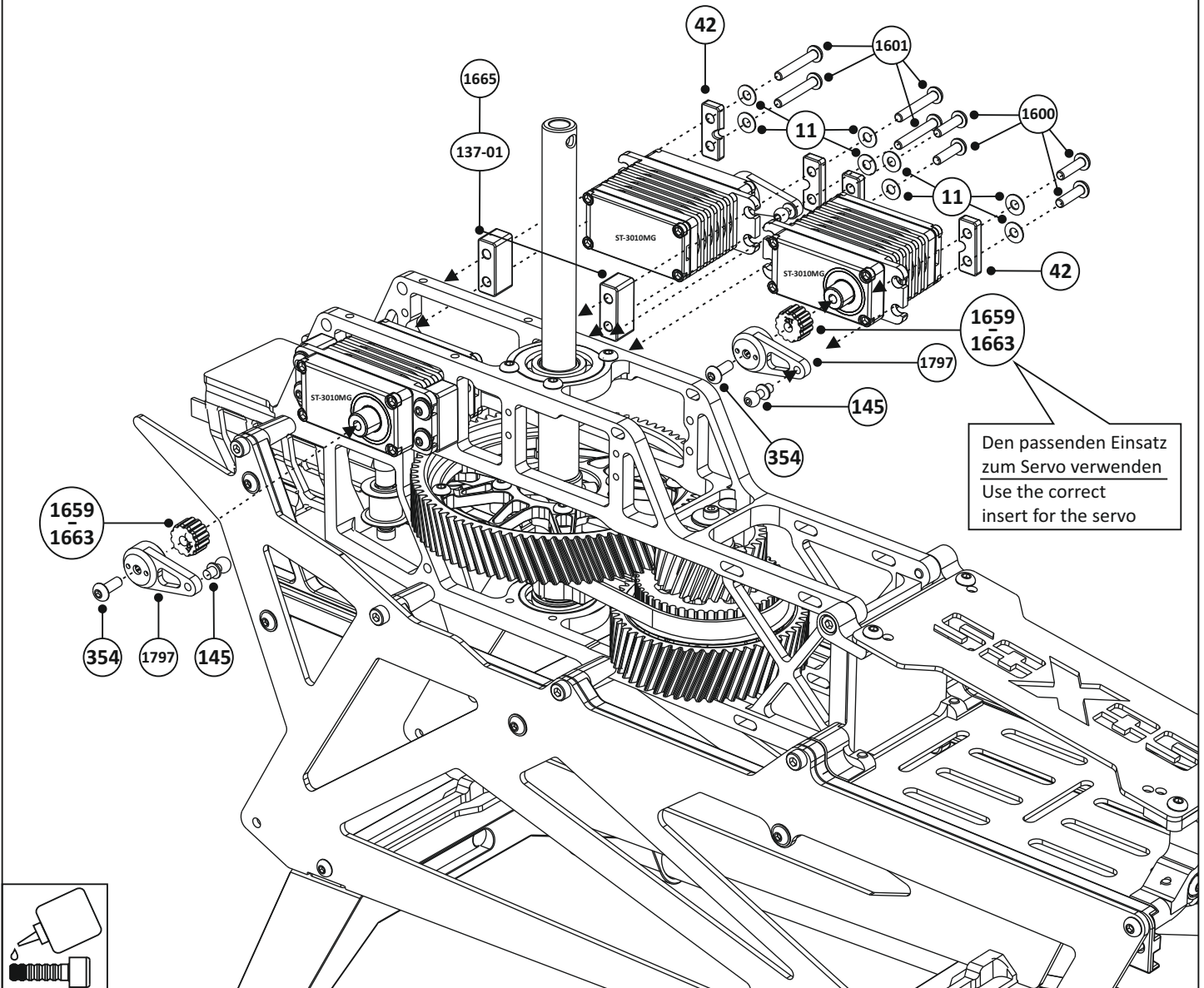



Normteile/Standard Parts

- 309** M3x7 Kugelpfanne Ball End Screw 2x

- 145** M3x4.5 Kugelpfanne Ball End Screw 4x

- 549** M3x7 Kugelpfanne lang Ball End Screw long 1x



- 155** M3x6 Rundkopfschraube Round Head Screw 2x

- 303** M3x8 Zylinderkopfschraube 2x Socket Head Screw

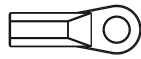

1:1

**62** Kugelpfanne Ball Link 6x



**1790** Taumelscheibe Swashplate 1x

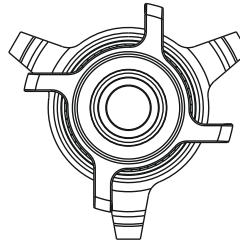

**548** Taumelscheibenführungs-Halter Swashplate Guide Holder 1x



**1825** Schubstange Control Rod 3x



**1799** Taumelscheibenführung Swashplate Guide 1x

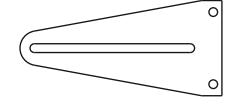

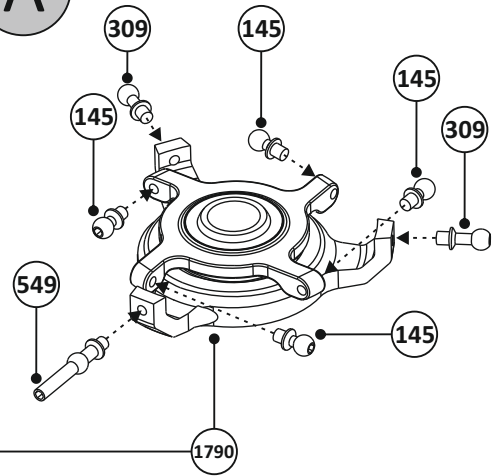

**A**

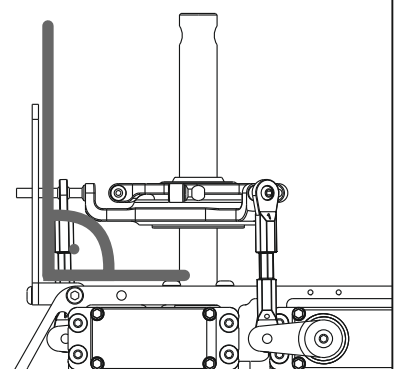
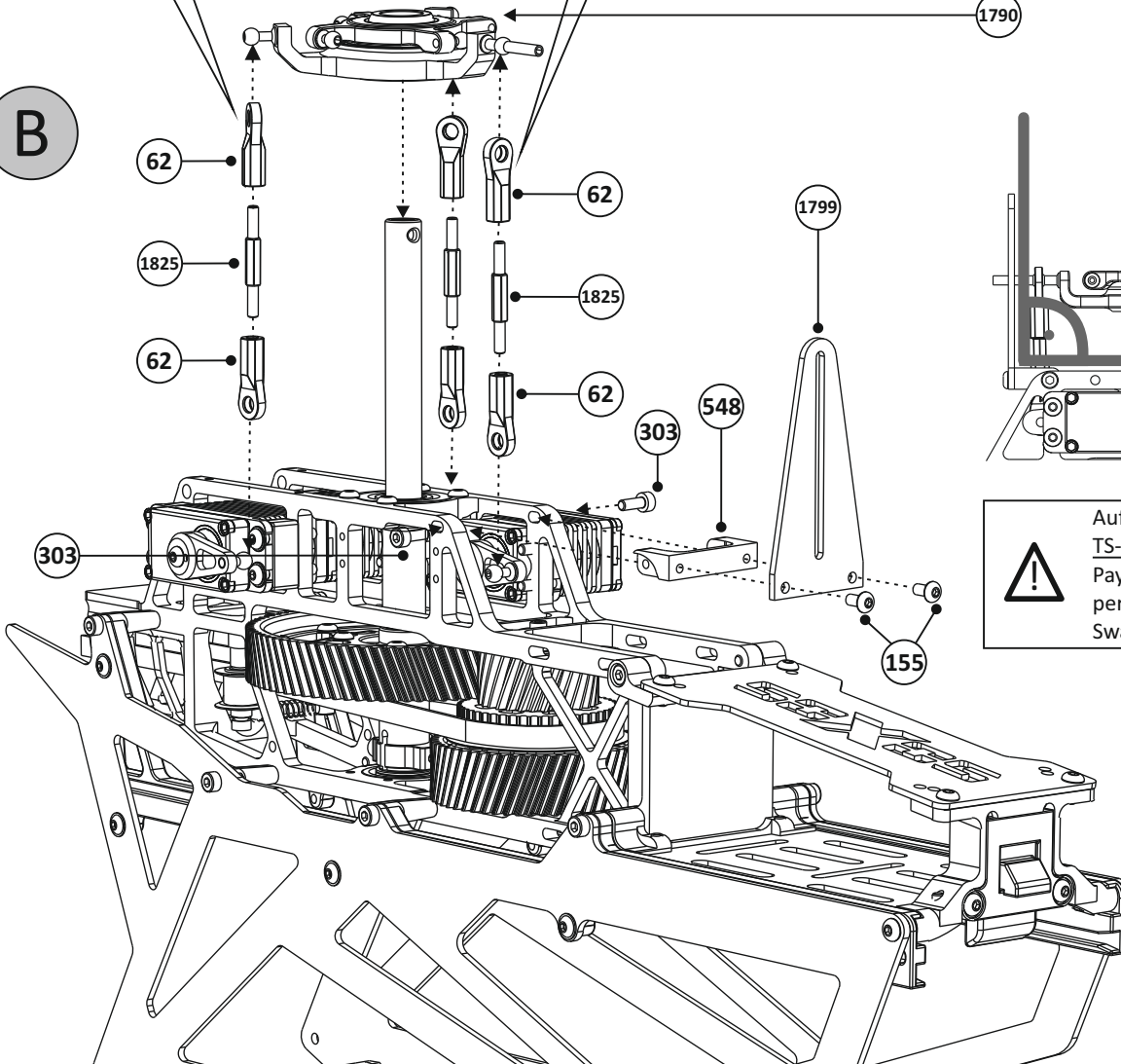

Schrauben Sie die Kugelpfannen 62 so weit wie möglich auf der Schubstange 1825 zusammen.  
Screw ball links 62 together as far as possible on the control rod 1825!

**B**



 Auf Rechtwinkligkeit der TS-Führung 1799 achten.  
Pay attention to the perpendicularity of the Swashplate Guide 1799.

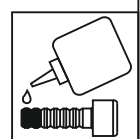

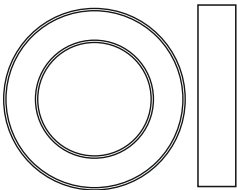

Normteile/Standard Parts

- 1800** 15x24x5 Kugellager  
Ball Bearing 1x

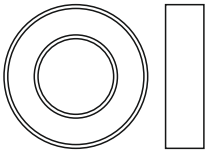

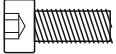
- 417** 10x19x5 Kugellager  
Ball Bearing 1x



- 528** M4x10 Zylinderkopfschraube 2x  
Socket Head Screw

- 71** M3x10 Zylinderkopfschraube 10x  
Socket Head Screw

- 155** M3x6 Rundkopfschraube 4x  
Round Head Screw



- 1820** M4x5 Gewindestift 2x  
Set Screw



- 11** M3 U-Scheibe 6x  
Washer

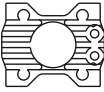

1:1

- 1754** Motorplatte 1x  
Motor Plate

  - 1755** Motor Gegenplatte 1x  
Motor Counterplate

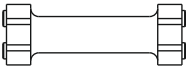

  - 1756** Distanz Platte 1x  
Distance Plate

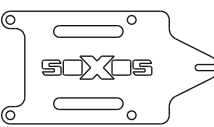
  - 1550 b** Empfängerplatte 1x  
Receiver Plate

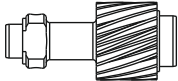
  - 2014** 16z/8mm/6mm Ritzel Alu  
Für Motoren von 820-850KV/6S  
16T/8mm/6mm Pinion Alu  
für Motoren von 820-850KV/6S

- Getriebe Übersetzungen:**  
(Ritzel sind erhältlich für 6mm und 8mm Motorwellen)  
**Gear Options:**  
(Pinions available for 6mm and 8mm motorshafts)
- 15 Zähne/Ratio:** 10.06
  - 16 Zähne/Ratio:** 9.43
  - 17 Zähne/Ratio:** 8.87
  - 18 Zähne/Ratio:** 8.38
  - 19 Zähne/Ratio:** 7.94

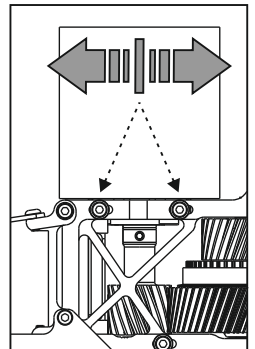
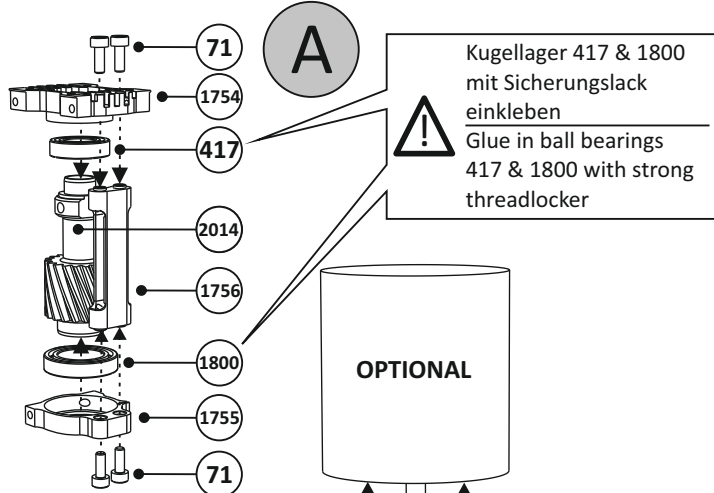
Beim Eindrehen der Motorschraube darauf achten, dass die Wicklungen des Motors nicht verletzt werden. Ggf. andere Schrauben verwenden.  
Make sure not to damage the windings with the motor screws. Use different screws if necessary.



Zahnflankenspiel anhand der Langlöcher einstellen.  
Adjust backlash with the slotted holes.



Adapter Hülse für 6mm Motorwelle. Bei Montage auf das Loch für Gewindestift achten.  
Adapter sleeve for 6mm motor shaft. When mounting, align to the hole for set screw.

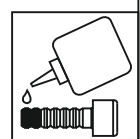
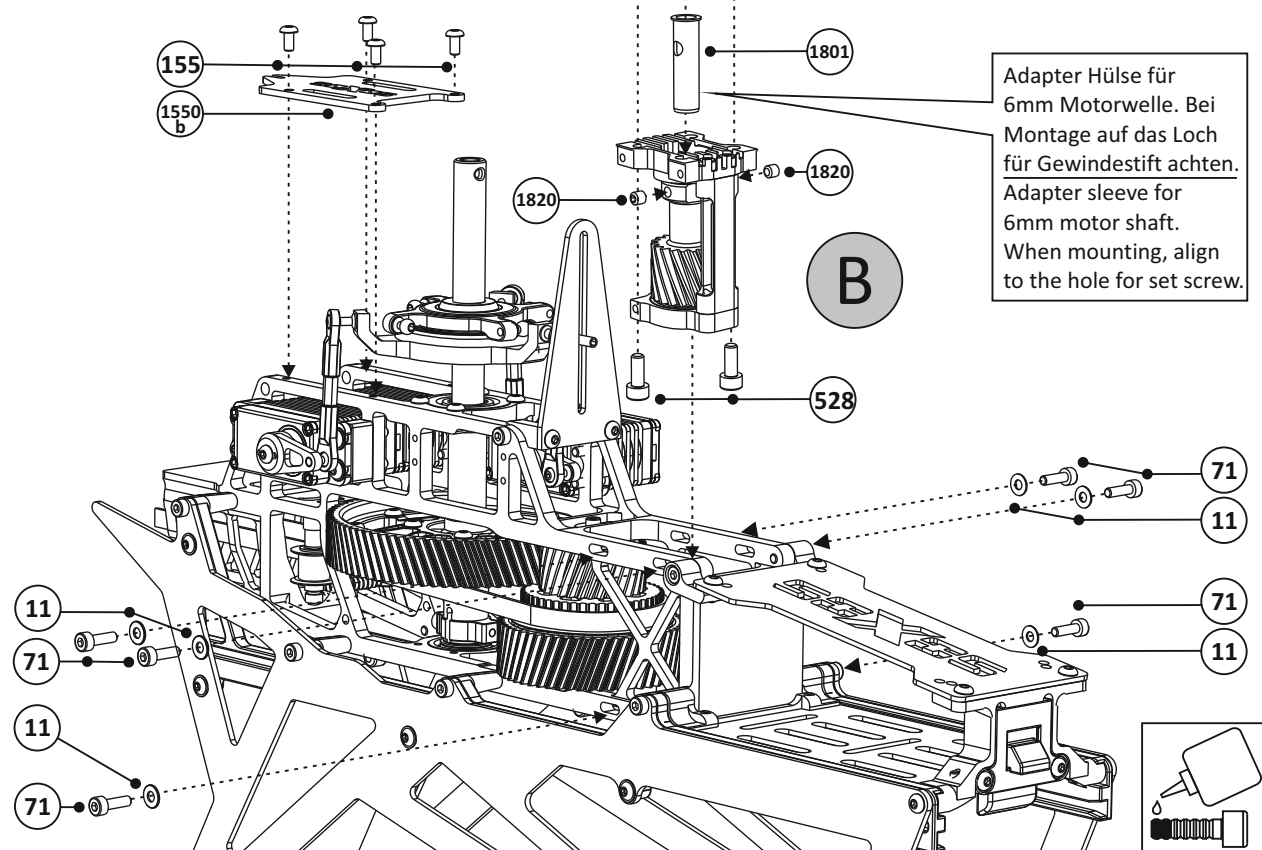

Normteile/Standard Parts

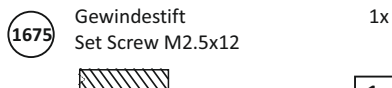
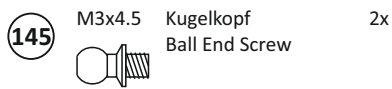
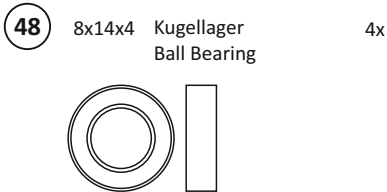
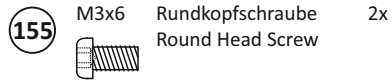
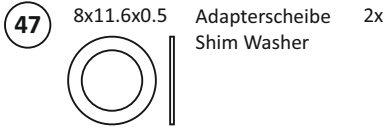
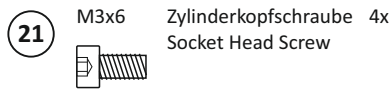
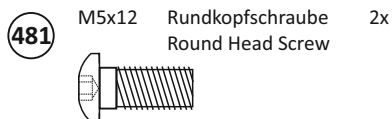
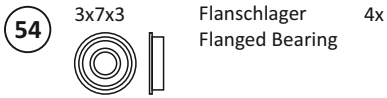

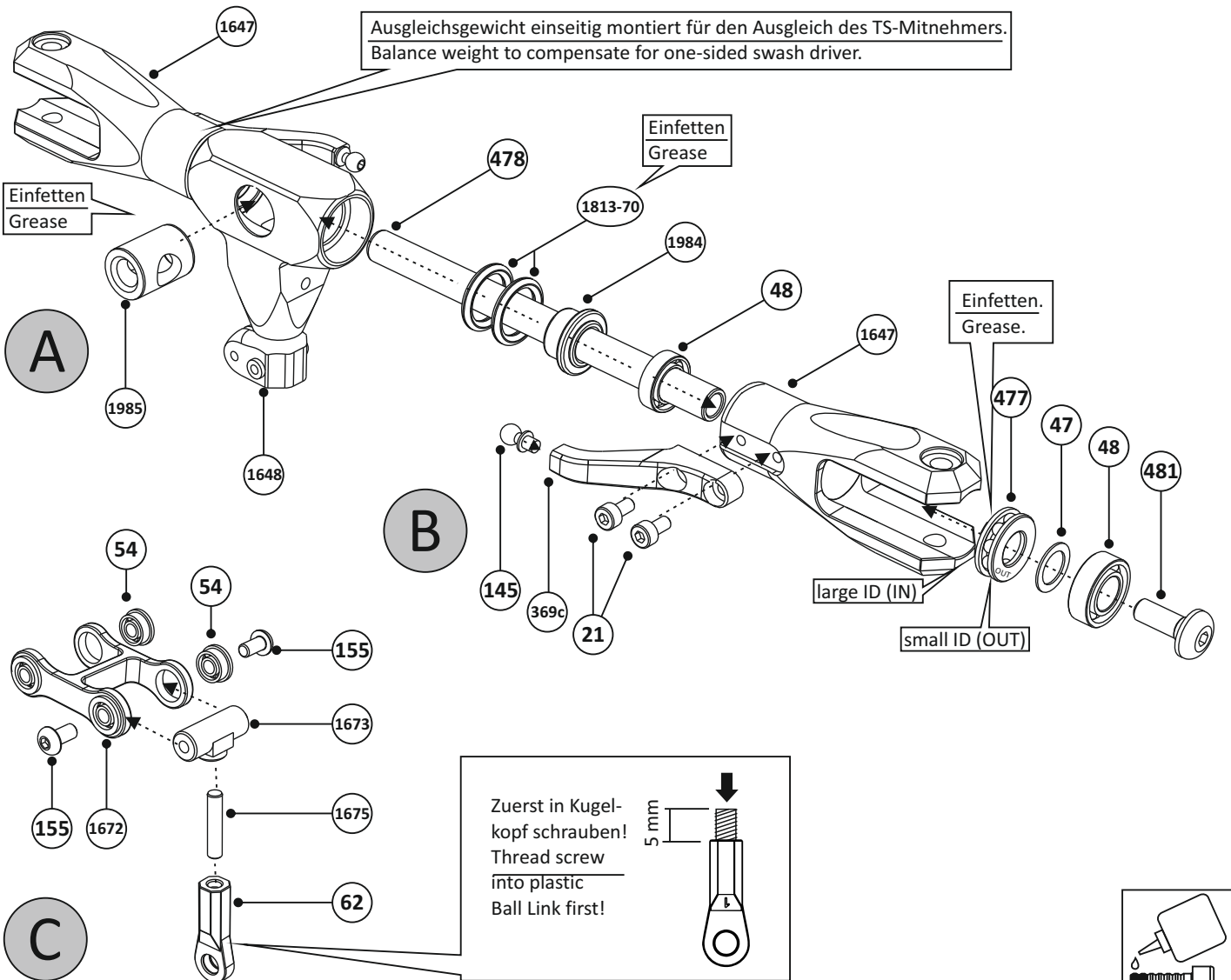
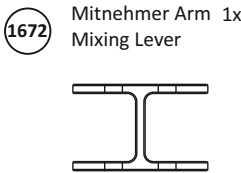
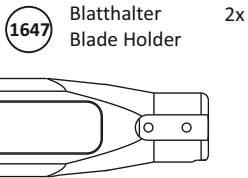
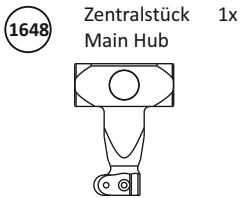
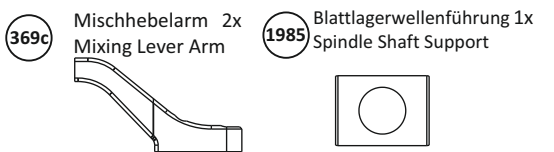
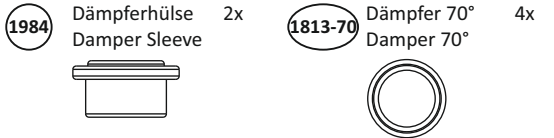
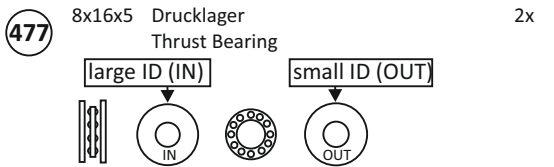

1:1



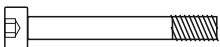

Normteile/Standard Parts

- 487** M3x25 Spezialschraube 1x  
Special Screw

- 18** M3 Stopmutter 1x  
Lock Nut



- 71** M3x10 Zylinderkopfschraube 1x  
Socket Head Screw



- 155** M3x6 Rundkopfschraube 2x  
Round Head Screw



1:1

- 1826** Anlenkgestänge  
(Links-Rechts Gewinde)  
Head Linkage Rod  
(Left and Right thread)

- 62** Kugelpfanne  
Ball Link



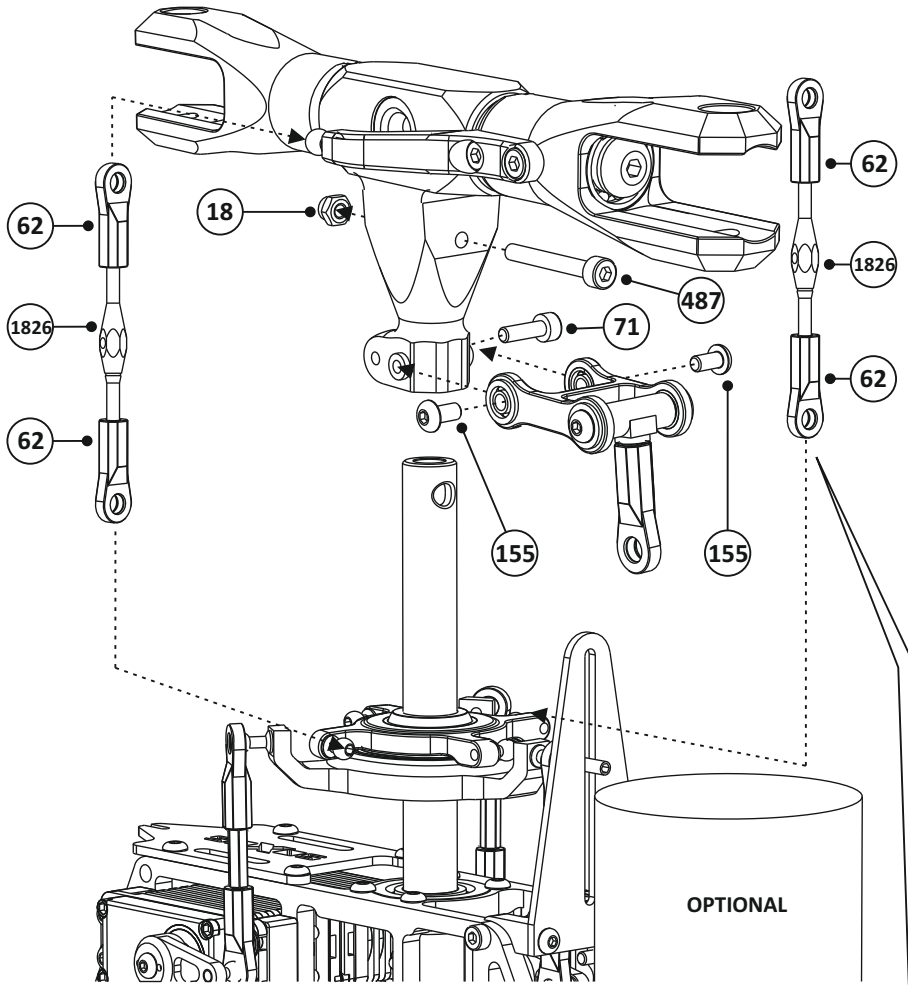

OPTIONAL

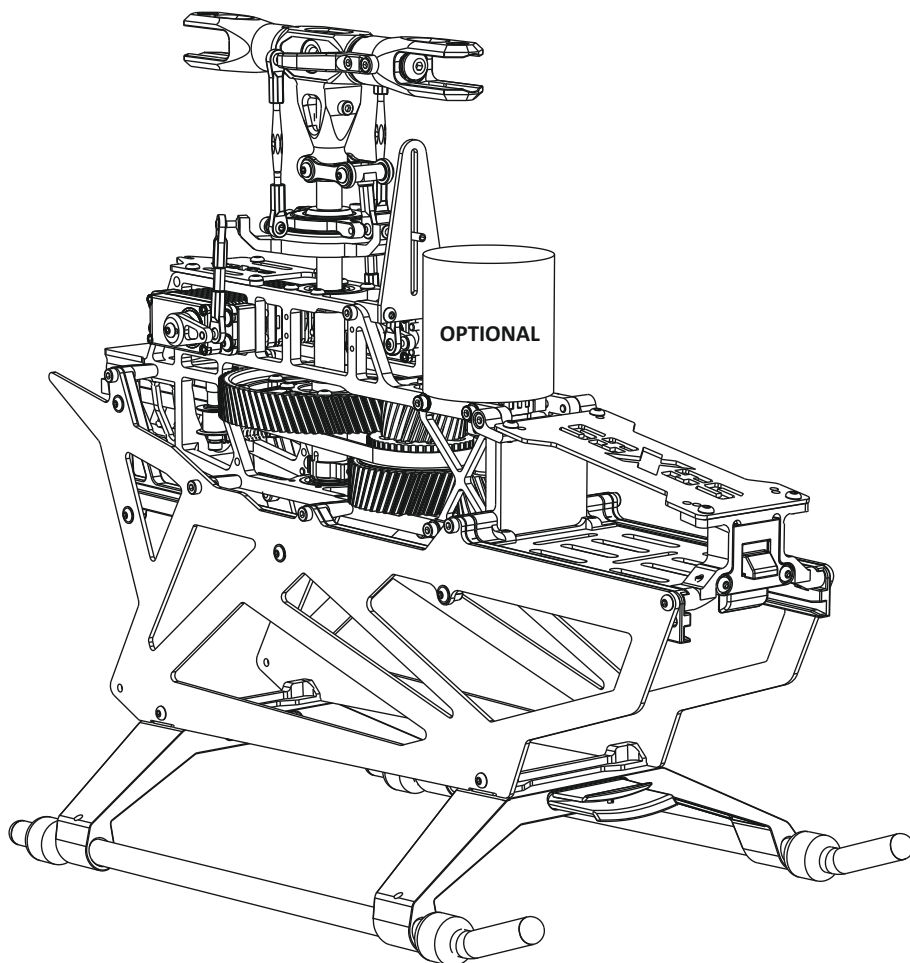

OPTIONAL

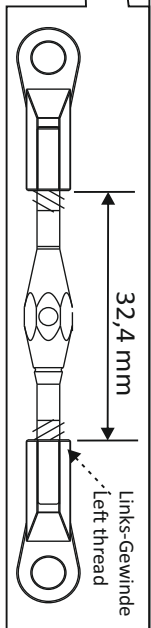

- 1989** Heckrohr 600  
Tail Boom 600      1x

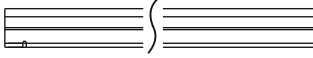
- 1765** Heckrotorgehäuse  
Tail Rotor Housing      1x

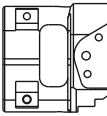

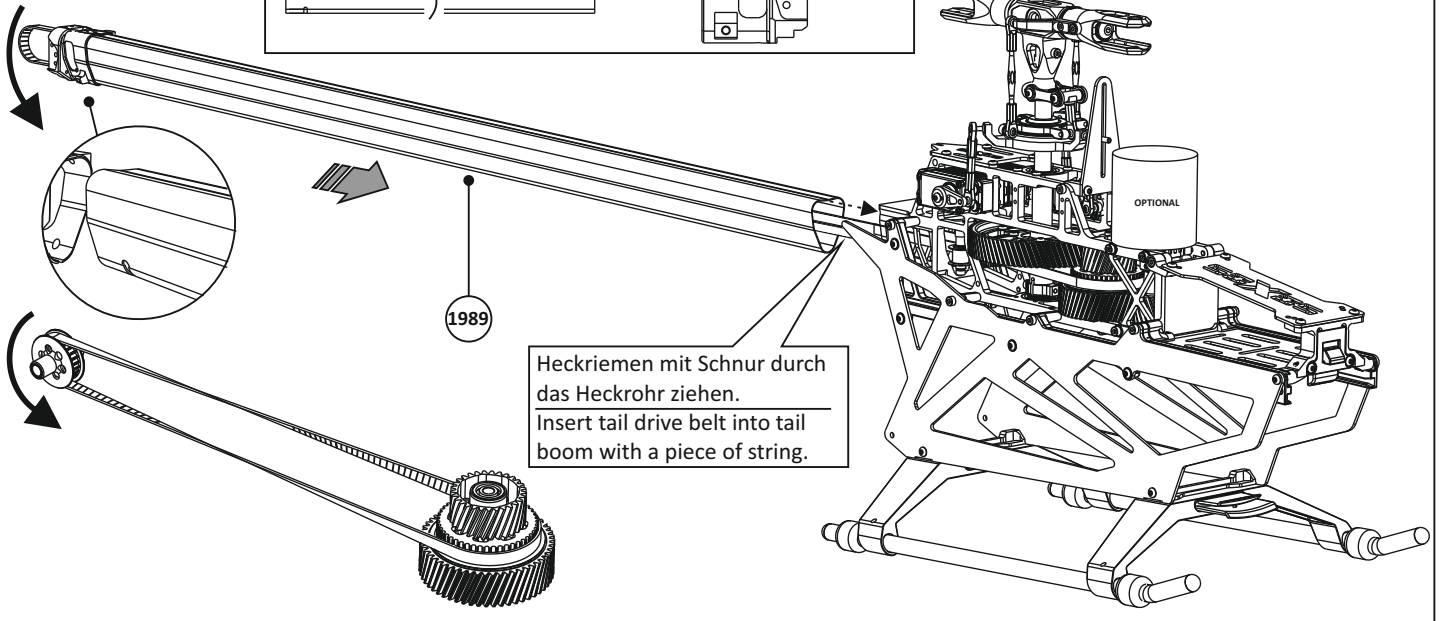

Normteile/Standard Parts

- 155**

M3x6

Rundkopfschraube  
Socket Head Screw

2x

- 303**

M3x8

Zylinderkopfschraube  
Socket Head Screw

2x

- 383**

8x12x3.5

Kugellager  
Ball Bearing

1x



1:1

- 1771** Drehstablagerung Heckgehäuse  
Torque Tube Support Tail      1x

- 1767** Seitenplatte Heckgehäuse  
Tail Rotor Housing Side Plates      1x



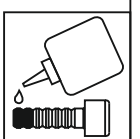
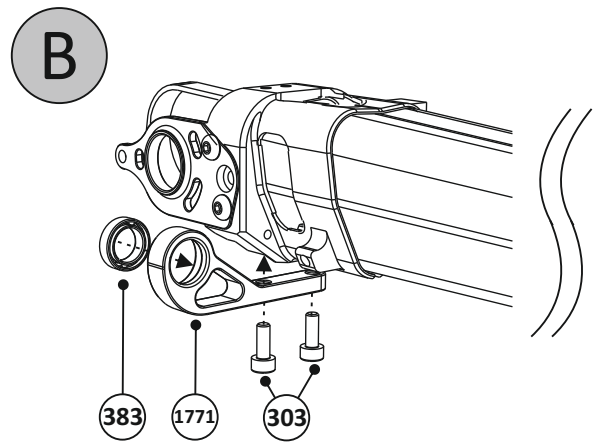
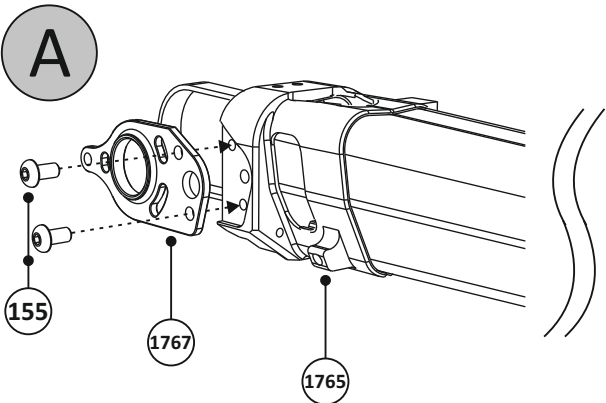

Normteile/Standard Parts

- 1787** M3x35 Rundkopfschraube 1x  
Round Head Screw
- 17** M3x20 Zylinderkopfschraube 2x  
Socket Head Screw
- 149** M3x12 Zylinderkopfschraube 1x  
Socket Head Screw
- 155** M3x6 Rundkopfschraube 1x  
Round Head Screw
- 296** 7x11x3 Kugellager 1x  
Ball Bearing
- 11** M3 U-Scheibe 1x  
Washer

1:1

**1668** Carbon Höhenleitwerk 1x  
Carbon Stabilizer Fin

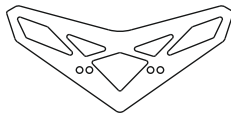

**266** Steuerhebel 1x  
Tail Lever

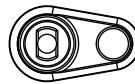

1x **1990** Drehstab  
Torque Tube

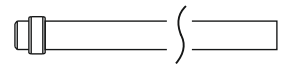

1x

**1781** Halterklemme oben 1x  
Upper Holder Clamp



1x **1782** Höhenleitwerkhalterklemme unten 1x  
Lower Stabilizer Fin Clamp

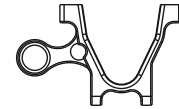

**1667** Carbon Seitenleitwerk 1x  
Carbon Vertical Fin

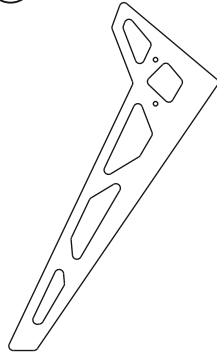

**448** Höhenleitwerksdistanz 2x  
Stabilizer Fin Spacer



**A**

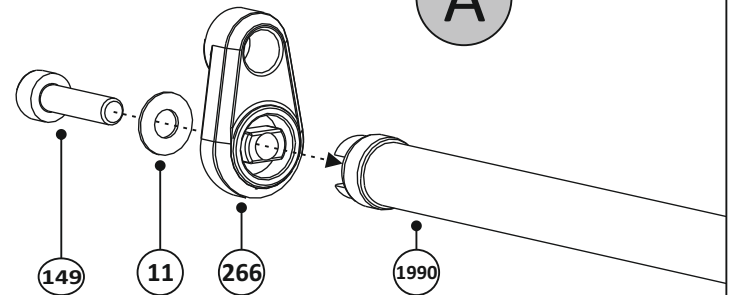

Diese Schrauben erst nach Montage der Heckstreben anziehen.  
Clamp with these screws after having installed the tail brace tubes.

**B**

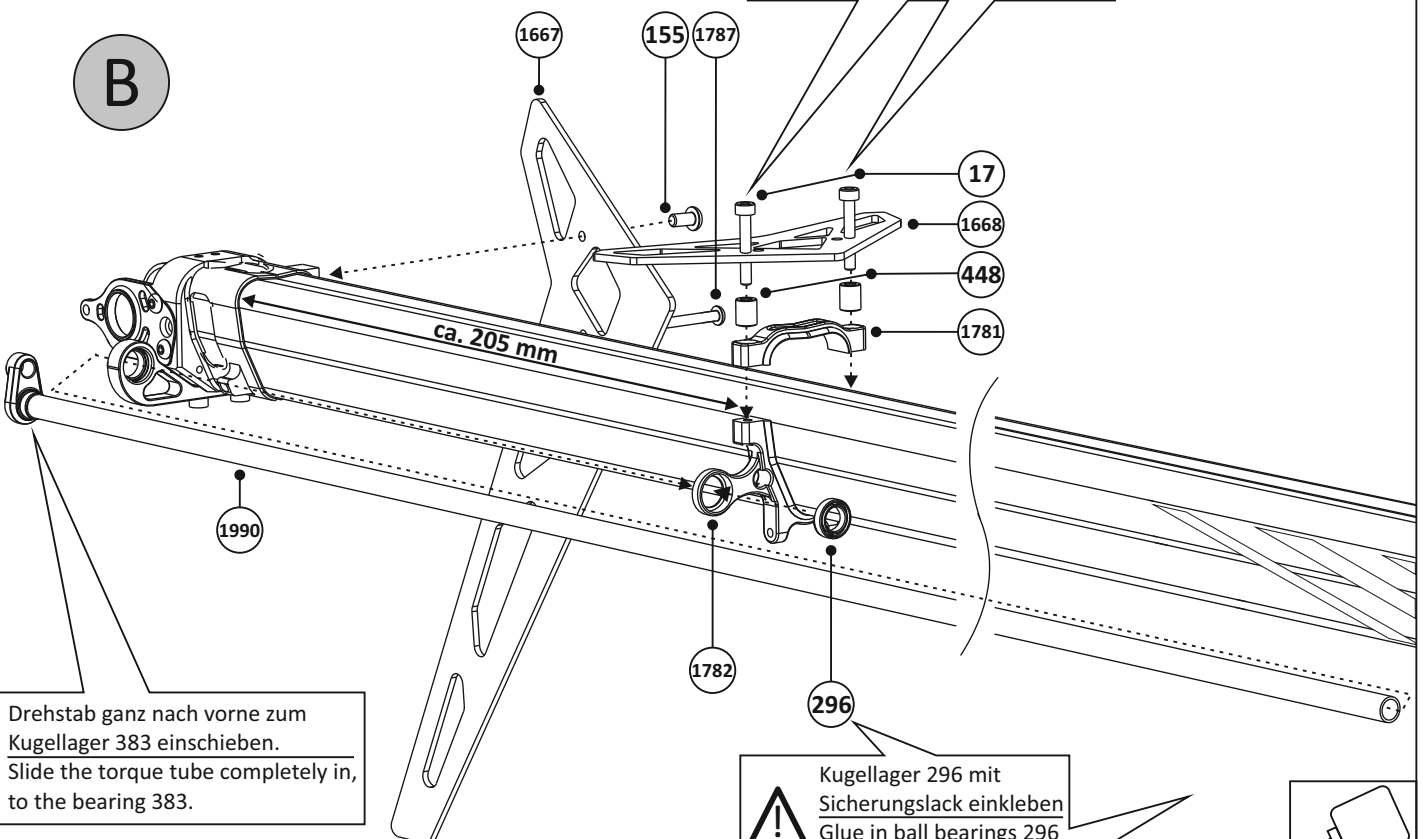

Drehstab ganz nach vorne zum Kugellager 383 einschieben.  
Slide the torque tube completely in, to the bearing 383.

**!** Kugellager 296 mit Sicherungslack einkleben  
Glue in ball bearings 296 with strong threadlocker

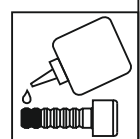



Normteile/Standard Parts

- 1600 M3x12 Rundkopfschraube 4x  
 Round Head Screw
- 71 M3x10 Zylinderkopfschraube 3x  
 Socket Head Screw
- 303 M3x8 Zylinderkopfschraube 1x  
 Socket Head Screw
- 11 M3 U-Scheibe 4x  
 Washer

1:1

1778 Halterklemme 1x  
 Holder Clamp



1x

1776 Heckservohalter 1x  
 Tail Servo Holder

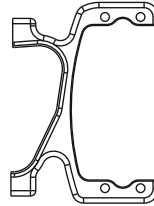

1x

1658 Drehstabhebel 1x  
 Torque Tube Lever

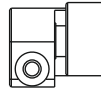

1x

41 Servoplättchen 2x  
 Servo Mounting Plates

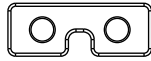

2x

1659  
1663

Servo Einsatz 23Z,24Z,25Z,25Z/8  
 Insert Servo 23T,24T,25T,25T/8



Den passenden Einsatz zum Servo verwenden  
 Use the correct insert for the servo

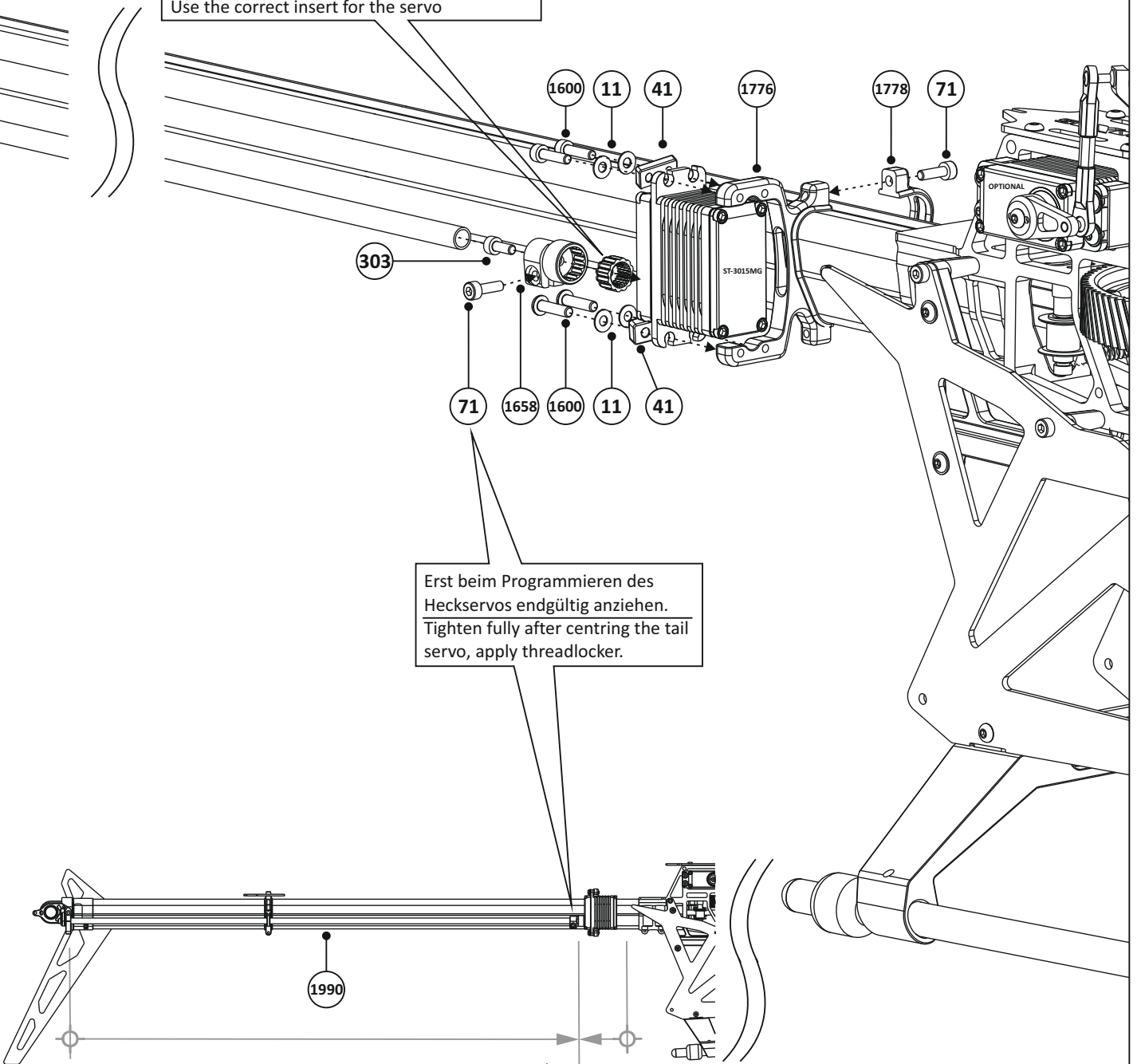

Erst beim Programmieren des Heckservos endgültig anziehen.  
 Tighten fully after centring the tail servo, apply threadlocker.

Drehstab ganz nach vorne schieben.  
 Push the Torque Tube all the way to the front.



Servo ganz nach hinten schieben.  
 Push the servo all the way back.

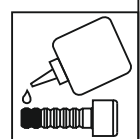

Normteile/Standard Parts

- |  |  |
|--|--|
| <b>145</b> M3x4.5 Kugelbolzen<br>Ball-End Screw 3x | <b>69</b> 7.5x9.9x0.4 Passscheibe<br>Shim Washer 2x            |
| <b>444</b> 5x1 O-Ring 2x                           | <b>443</b> 5.2x7.5x0.7 Passscheibe<br>Shim Washer 2x           |
| <b>68</b> 5x10x4 Kugellager<br>Ball Bearing 2x     | <b>503</b> M2x5.5 Zylinderkopfschraube 2x<br>Socket Head Screw |
| <b>74g</b> 6x10x3 Kugellager<br>Ball Bearing 2x    | <b>303</b> M3x8 Zylinderkopfschraube 2x<br>Socket Head Screw   |

- |   |   |
|---|---|
| <b>1711-1</b> Heckrotornabe<br>Tail Rotor Hub 1x  | <b>1704</b> Blatthalter Heckrotor<br>Blade Holder Tail Rotor 2x |
| <b>151</b> 5x10x4 Drucklager<br>Thrust Bearing 2x | <b>1773</b> Hecksteuerbrücke<br>Tail Pitch Control 1x           |
| large ID (IN) small ID (OUT)                      |   |
| <b>70</b> 3x7.5x1 Unterlegscheibe 2x<br>Washer    | <b>268</b> Hecksteuerbrückenarme 2x<br>Tail Pitch Control Arms  |

1:1

Punkt auf 268 muss Richtung Schraubenkopf 503 sein.  
Raised dot on 268 must be in direction screw head 503.

Kugellager werksseitig bereits montiert.  
Ball bearing already assembled.

Einfetten.  
Grease.

Werksseitig bereits montiert und gesichert.  
Factory assembled and secured.

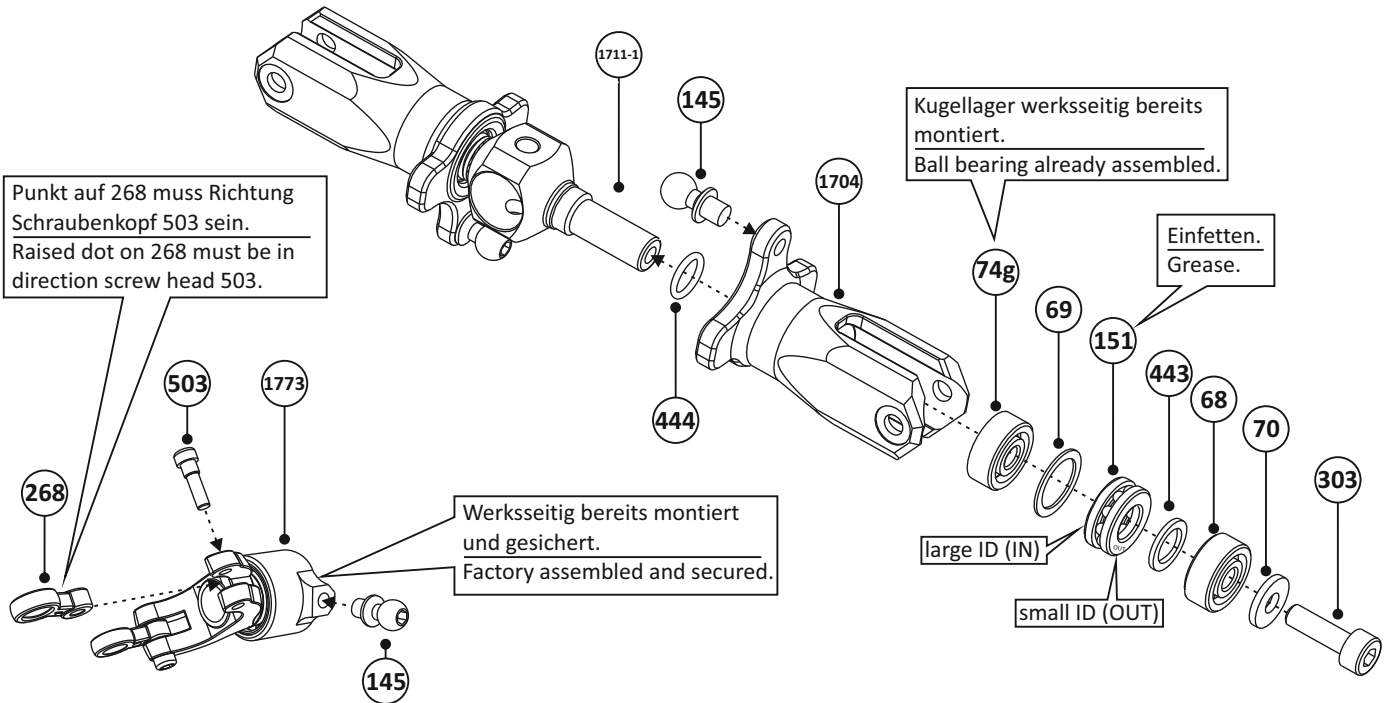

Normteile/Standard Parts

- |   |  |
|---|--|
| <b>33</b> M4x4 Gewindestift<br>Set Screw 1x       |  |
| <b>1714</b> Dämpfergummi<br>Damper Rubber 4x      |  |
| <b>1715</b> 3x13 Bolzen<br>Bolt 1x                |  |
| <b>1768</b> Heckrotorwelle<br>Tail Rotor Shaft 1x |  |

1:1

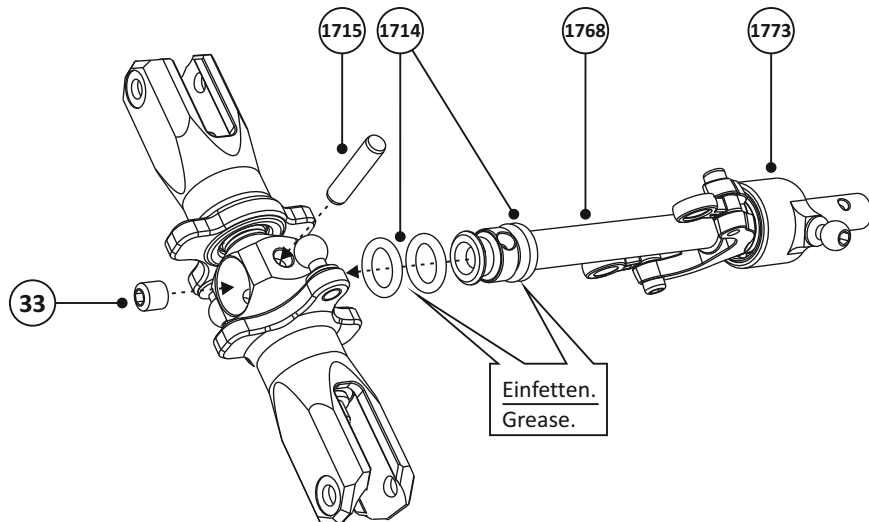

Einfetten.  
Grease.



Normteile/Standard Parts

<b>1600</b>	M3x12 Rundkopfschraube 1x Round Head Screw	<b>376</b>	6x13x5 Flanschlager Flanged Bearing	2x	<b>1769</b>	Heckantriebsrolle 26Z Tail Drive Pulley 26T	1x	<b>1772</b>	Kugellagerhalter Bearing Stand	1x
<b>155</b>	M3x6 Rundkopfschraube 6x Round Head Screw	<b>1802</b>	3x8x3 Kugellager Ball Bearing	2x	<b>1770</b>	Distanz Heckgehäuse Spacer Tail Rotor Housing	1x	<b>1767</b>	Seitenplatte Heckgehäuse Tail Rotor Housing Side Plates	1x
<b>33</b>	M4x4 Gewindestift Set Screw				<b>1774</b>	2x10 Bolzen Pin	1x			

1:1

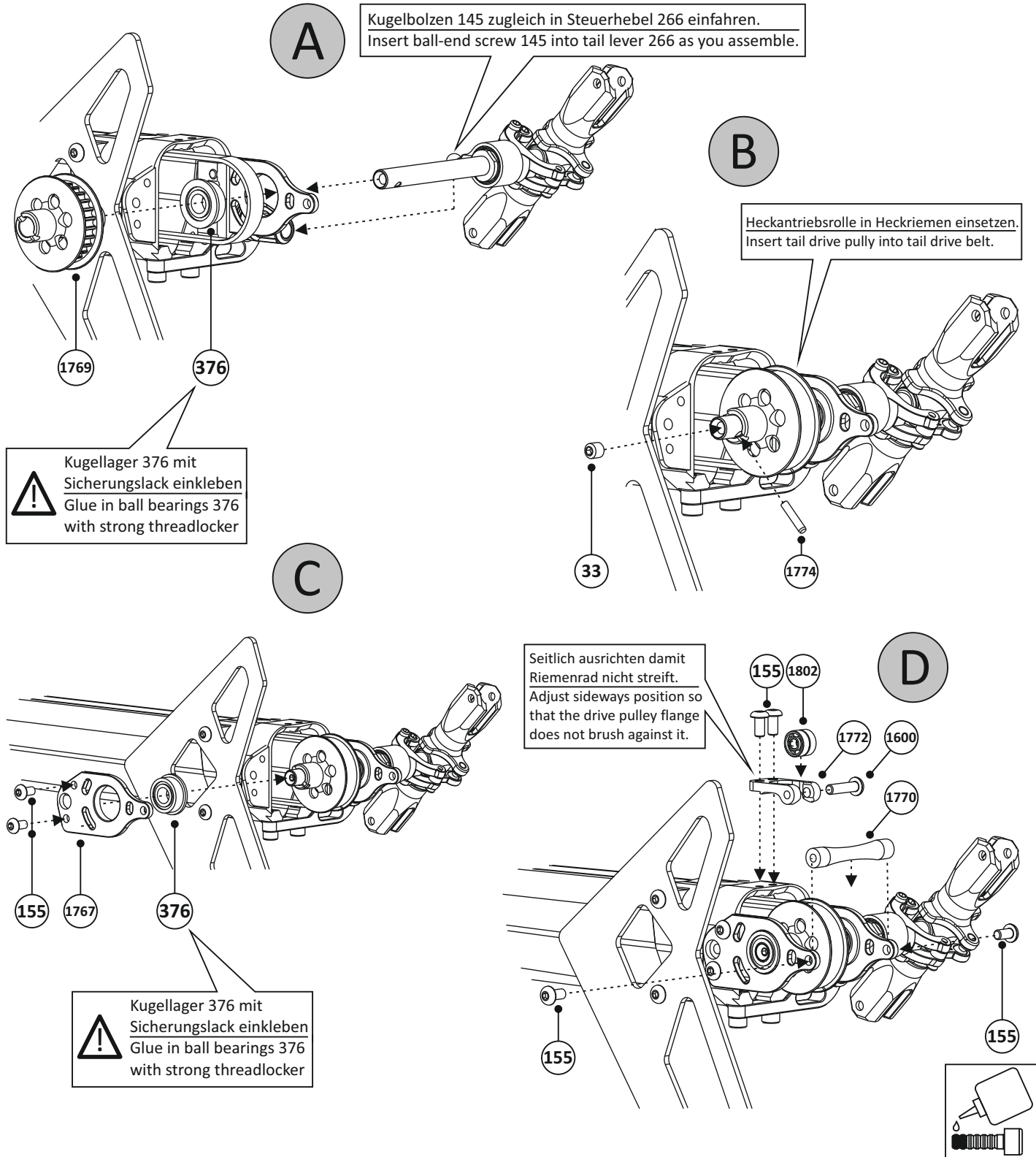

Normteile/Standard Parts

- 77 M3x16 Zylinderkopfschraube 2x  
Socket Head Screw

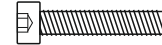

1:1



Heckriemen spannen: Riemen spannen, bis Riemenspanner vollständig am äusseren Anschlag ist, aber nicht überspannen!  
Tighten tail drive belt: Tension the belt until the belt tensioner is touching the outer stop, but do not over tension!

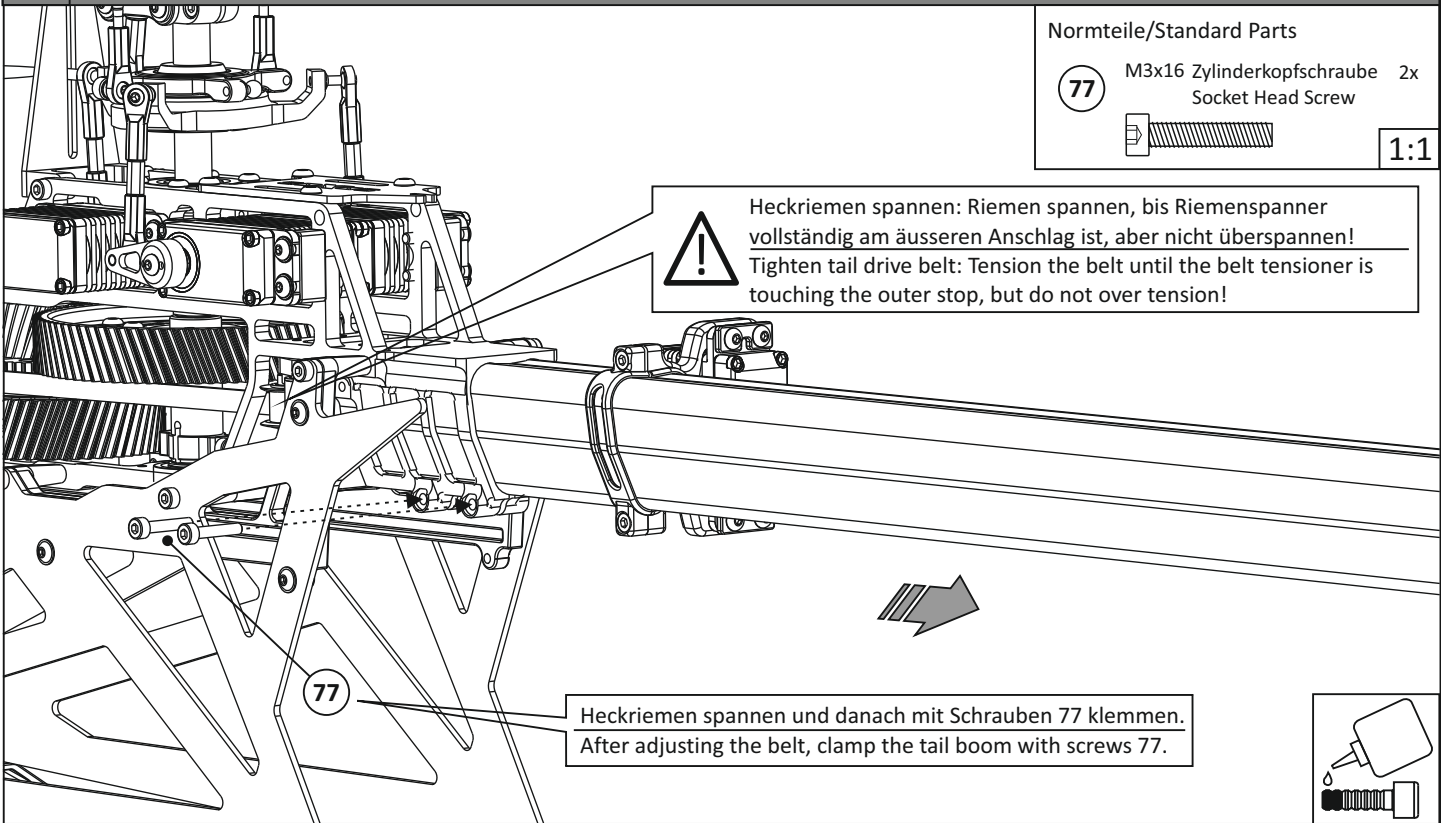

Heckriemen spannen und danach mit Schrauben 77 klemmen.  
After adjusting the belt, clamp the tail boom with screws 77.

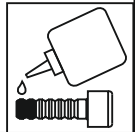

Normteile/Standard Parts

- 1684 M3x10 Rundkopfschraube 1x  
Round Head Screw



- 354 M3x8 Rundkopfschraube 2x  
Round Head Screw



- 54 3x7x3 Flanschlager 2x  
Flanged Bearing



1:1

- 1805 Federhülse 1x  
Spring Sleeve

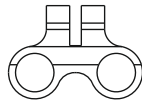

- 1695 Stift 2.5x15mm 2x  
Pin



- 1977 Haubenhalter 1x  
Canopy Holder Carbon

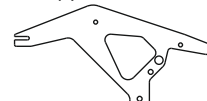

- 1806 Sicherheitshebel 1x  
Safety Lever



- 1807 Stehbolzen 1x  
Stud Bolt



- 1808 Mutter 1x  
Nut



- 1804 Druckfeder 2x  
Pressure Spring

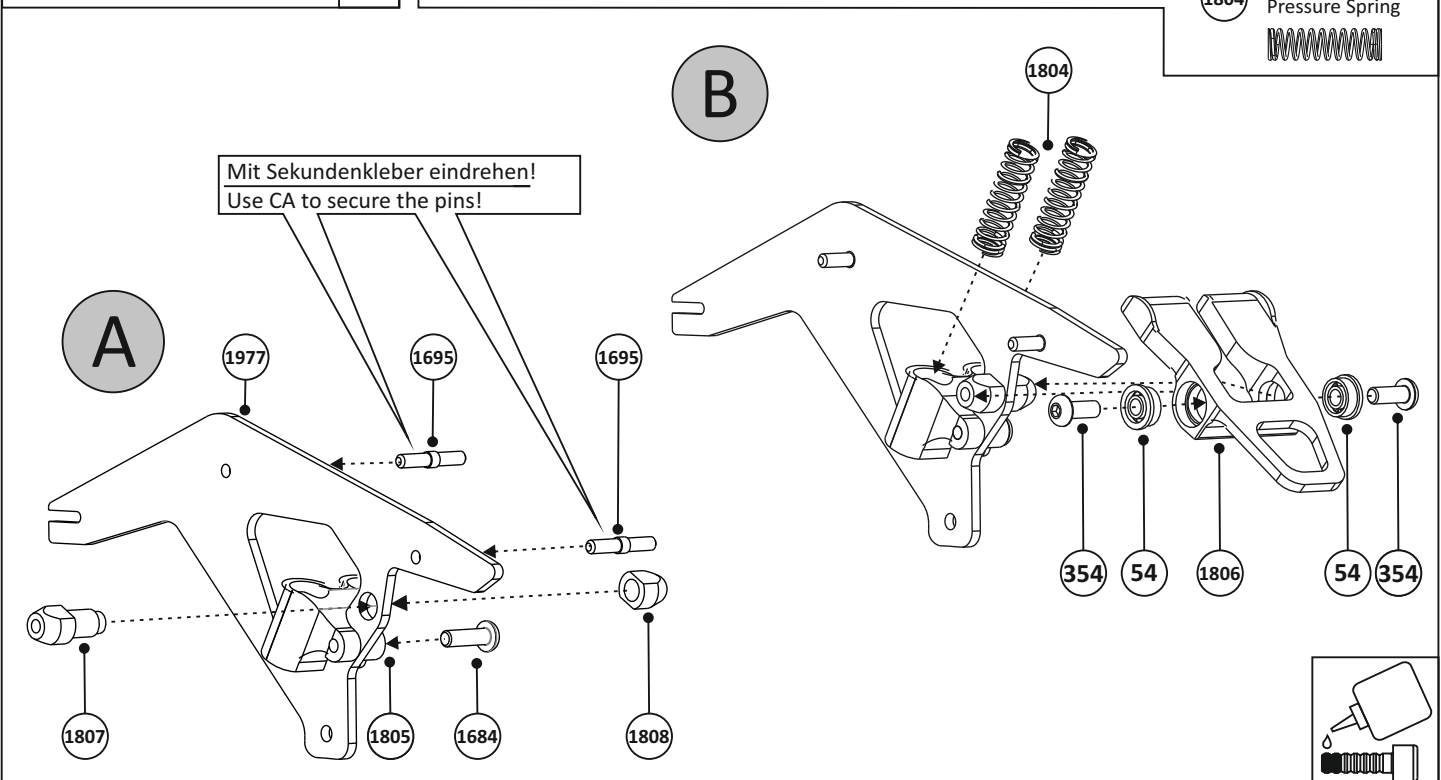

Mit Sekundenkleber eindrehen!  
Use CA to secure the pins!

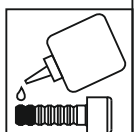

Normteile/Standard Parts

**18** M3 Stopmutter  
Lock Nut 2x

**71** M3x10 Zylinderkopfschraube  
Socket Head Screw 4x

**303** M3x8 Zylinderkopfschraube  
Socket Head Screw 2x

1:1

**1778** Halterklemme  
Holder Clamp 1x



**1779** Halterklemme M3  
Holder Clamp M3 1x



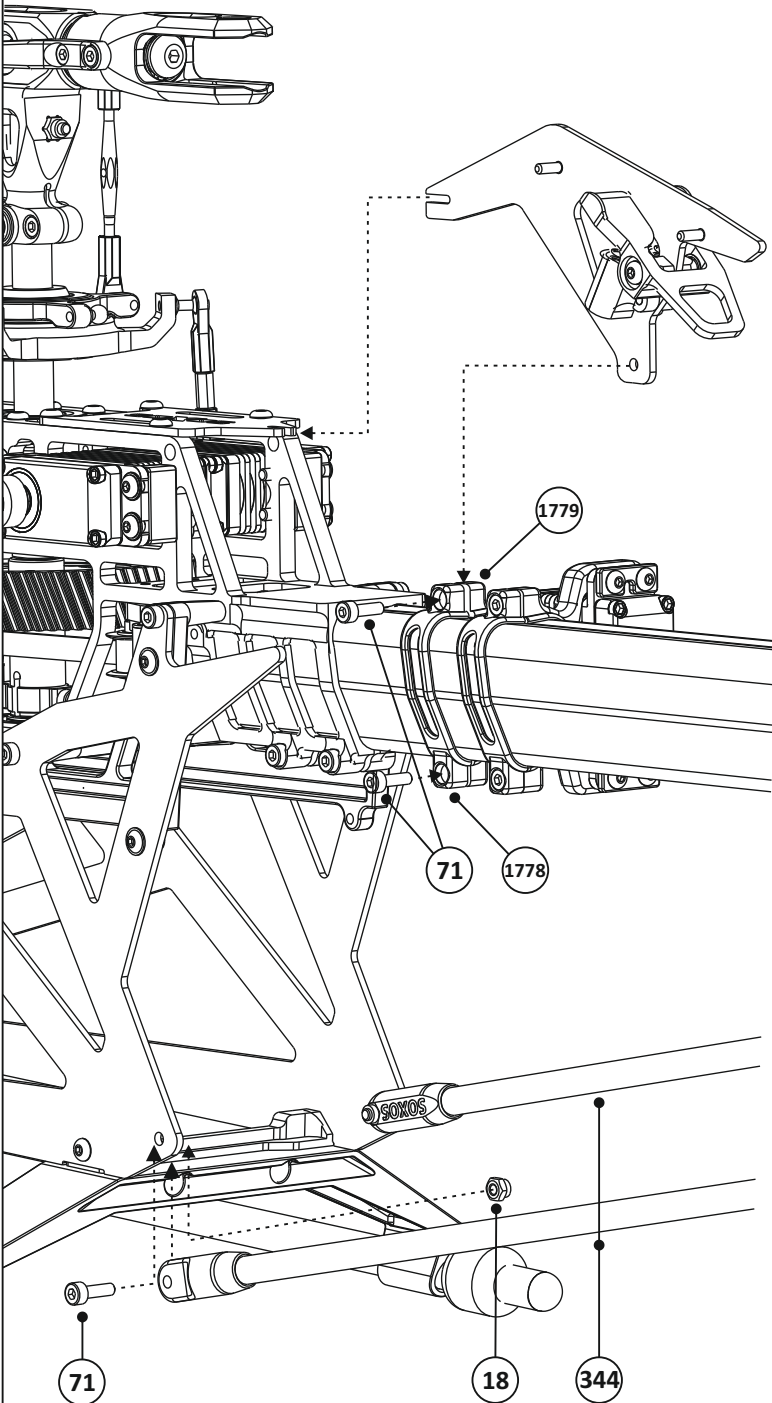
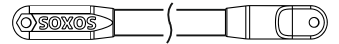

**344** Heckstrebe  
Tail Brace Tube 2x



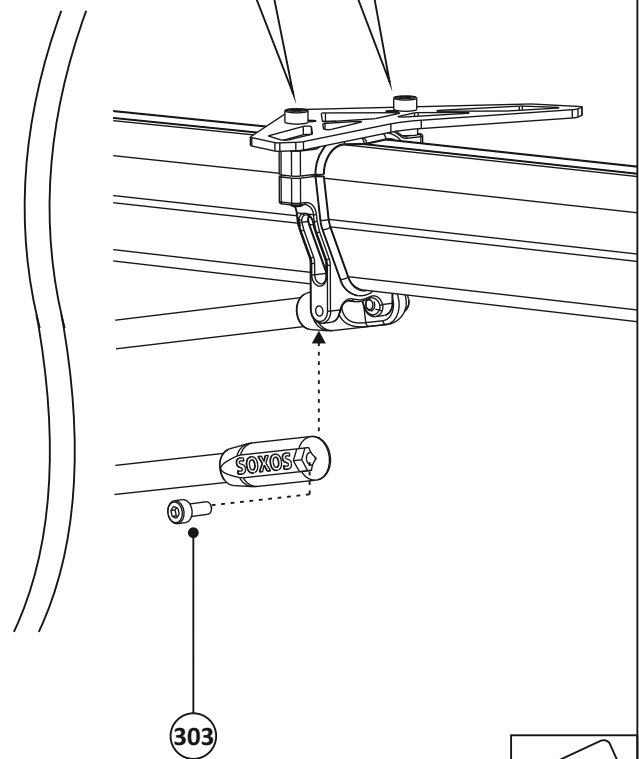

Diese Schrauben erst nach Montage  
der Heckstreben anziehen.  
Clamp with these screws after  
having installed the tail brace tubes.

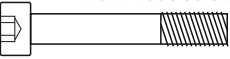
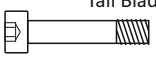

Normteile/Standard Parts

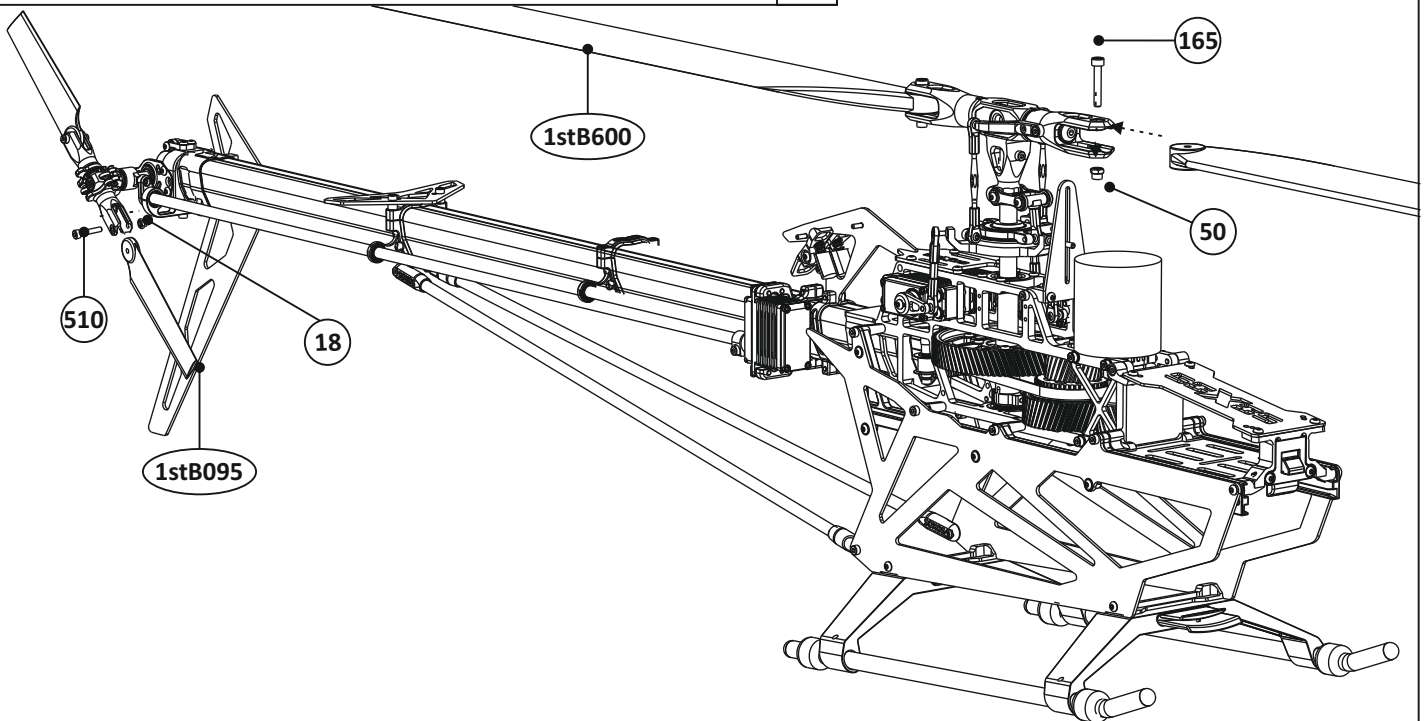
- |  |   |
|--|---|
| <p><b>18</b> M3 Stopmutter<br/>Lock Nut 2x</p>                          | <p><b>165</b> M4x24 Hauptrotorblattschraube 2x<br/>Main Blade Screw</p>  |
| <p><b>510</b> M3x16 Heckrotorblattschraube 2x<br/>Tail Blade Screw</p>  | <p><b>50</b> M4 Stopmutter<br/>Lock Nut 2x</p>                           |
- 1:1**

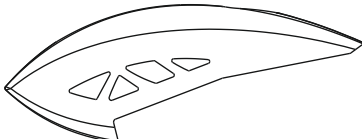

- |  |   |
|--|---|
| <p><b>259</b><br/>C6.1 Haube Strike 6.1<br/>Canopy Strike 6.1 1x</p>  | <p><b>517</b> Akkuplatte<br/>Battery Plate 1x</p>  |
|--|---|

Justieren Sie die Balance des Helikopters mit der Positionierung des Akkus auf der Akkuplatte (inkl. Haube). Verwenden Sie das mitgelieferte Klettband, um den Akku zu sichern. Der Akku darf sich während des Fluges nicht verschieben.  
Adjust the helicopter's balance with the position of the battery pack on the battery plate (incl. canopy). Use the supplied Velcro to secure the battery, the pack must not shift during flight.

