

Teleskopplader mit Abstützungen

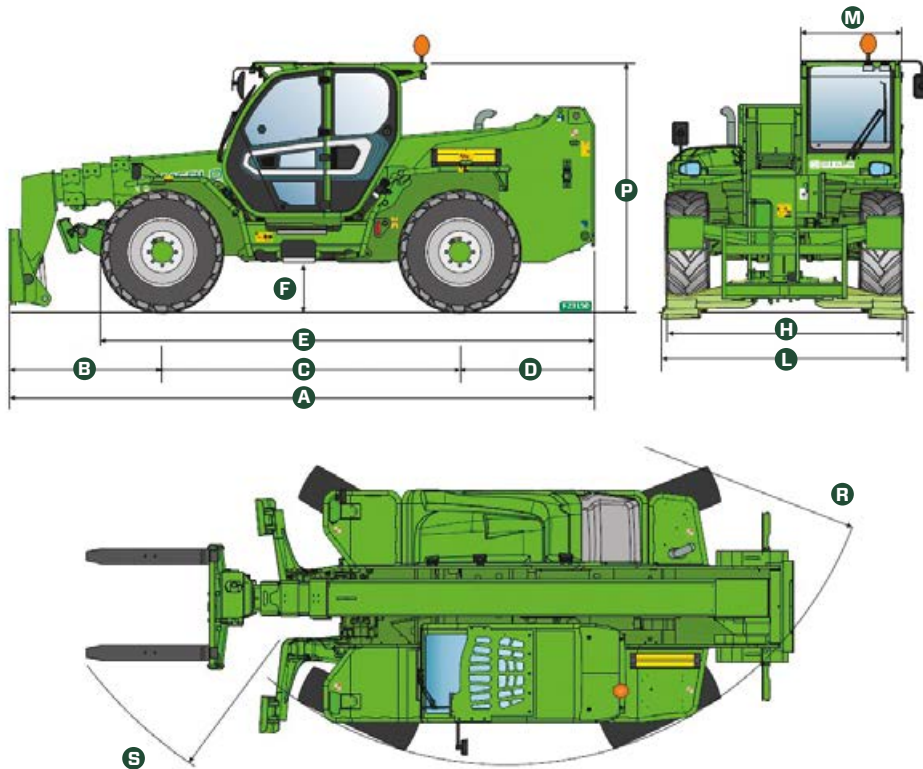

Technische Daten



MODELL	ABMESSUNGEN	A	B	C	D	E	F	H	L	M	P	R	S
P30.10	mm	4700	1360	2740	600	3910	290	2100	-	1010	2120 (2020 L)	3930	5050
P35.11	mm	5150	1634	2810	705	4104	460	2310	-	1010	2530	3985	5200
TF35.11TT-145	mm	5150	1634	2810	705	1404	460	2310	-	1010	2530	3985	5200
P40.12	mm	5010	1290	2810	910	4260	375	2240	2380	1010	2425	3920	4900
P40.12PLUS	mm	5010	1290	2810	910	4260	375	2240	2380	1010	2425	3920	4900
P40.13	mm	5410	1690	2810	910	4260	375	2240	2380	1010	2425	3920	4940
P40.13PLUS	mm	5410	1690	2810	910	4260	375	2240	2380	1010	2425	3920	4940
P40.13CSTOP	mm	5410	1690	2810	910	4260	375	2240	2380	1010	2425	3920	4940
P40.14	mm	5750	1645	2810	1295	4640	375	2240	2380	1010	2425	3920	5040
P40.14PLUS	mm	5750	1645	2810	1295	4640	375	2240	2380	1010	2425	3920	5040
P40.14CSTOP	mm	5750	1645	2810	1295	4640	375	2240	2380	1010	2425	3920	5040
P40.17	mm	5970	1705	2950	1315	4852	450	2240	2550	1010	2500	4050	5160
P40.17PLUS	mm	5970	1705	2950	1315	4852	450	2240	2550	1010	2500	4050	5160
P40.17CSTOP	mm	5970	1705	2950	1315	4852	450	2240	2550	1010	2500	4050	5160
P50.18PLUS	mm	6190	1745	3060	1385	5067	485	2480	2550	1010	2535	4265	5611
P50.18CSTOP	mm	6190	1745	3060	1385	5067	485	2480	2550	1010	2535	4265	5611

*Kabinenfederung aktiviert

MODELL	P30.10	P35.11	TF35.11TT-145	P40.12	P40.12PLUS	P40.13	P40.13PLUS
Gesamtleergewicht (kg)	7600	9000	9100	9200	9200	9300	9300
Maximale Tragkraft (kg)	3000	3500	3500	4000	4000	4000	4000
Hubhöhe (m)	9,8	11	11	11,5	11,5	12,5	12,5
Maximale Ausladung (m)	6,7	7,8	7,8	7,63	7,63	8,74	8,74
Ausladung bei maximaler Tragfähigkeit (m)	2,5	2	2	3,4	3,4	3,3	3,3
Tragfähigkeit bei maximaler Ausladung (kg)	1000	1000	1000	1300	1300	1000	1000
Seitenverschub des Rahmens (mm)	-	+/- 310	+/- 310	+/- 330	+/- 330	+/- 340	+/- 340
Niveaueingleich (%)	-	+/- 8	+/- 8	+/- 8	+/- 8	+/- 8	+/- 8
Motor	Kohler 2504 TCR	Kohler 2504 TCR	Deutz TCD3.6	Kohler KDI2504	Perkins 904J	Kohler KDI2504	Perkins 904J
Motorleistung (kW/PS)	55,4/75,1	55,4/75,1	105/143	55,4/75,1	85,9/115	55,4/75,1	85,9/115
Abgasreinigungstechnologie	Stage V DOC + DPF	Stage V DOC + DPF	Stage V SCR + DPF + DOC	Stage V DOC + DPF	Stage V SCR + DPF + DOC	Stage V DOC + DPF	Stage V SCR + DPF + DOC
Höchstgeschwindigkeit (km/h)	20/35 (opt.)	20/35 (opt.)	20/40 (opt.)	20/35 (opt.)	20/40 (opt.)	20/35 (opt.)	20/40 (opt.)
Kraftstofftank (l)	80	140	140	140	140	140	140
AdBlue-Behälter (l)	-	-	18	-	18	-	18
Hydrostatischer Antrieb	JA - 2-Gang	JA - 2-Gang	JA - 2-Gang	JA - 2-Gang	JA - 2-Gang	JA - 2-Gang	JA - 2-Gang
EPD	Plus	Plus	Plus	Plus	Plus	Plus	Plus
Hydraulikpumpe	LS+FS	LS + FS	LS + FS	LS	LS	LS	LS
Durchfluss/Druck (l/min - bar)	117-210	117 - 250	150-250	104 - 250	104 - 250	104 - 250	104 - 250
Hydraulikölbehälter (l)	85	100	100	100	100	100	100
Kabineausstattung	ECO	ECO	ECO	ECO	ECO	ECO	ECO
ASCS	Light	Light	Light	Light	Full	Light	Full
Kabine FOPS II, ROPS	JA	JA	JA	JA	JA	JA	JA
Bedienelemente in Kabine	Kapazitiver Joystick	Kapazitiver Joystick	Kapazitiver Joystick	Kapazitiver Joystick	Kapazitiver Joystick	Kapazitiver Joystick	Kapazitiver Joystick
Fahrtrichtungsschalter	Dual Reverse	Dual Reverse	Dual Reverse	Dual Reverse	Dual Reverse	Dual Reverse	Dual Reverse
Schwingungsdämpfung am Hubzylinder BSS	OPT	OPT	OPT	OPT	OPT	OPT	OPT
Tac-Lock	JA	JA	JA	JA	JA	JA	JA
Allradantrieb	JA	JA	JA	JA	JA	JA	JA
Allradlenkung	JA	JA	JA	JA	JA	JA	JA

P30.10

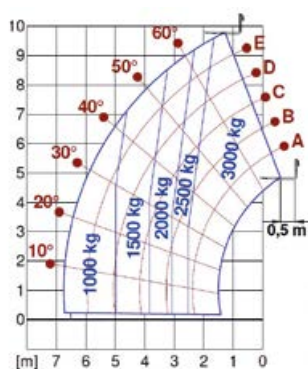

P35.11

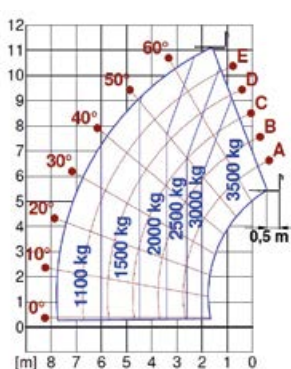

P40.12

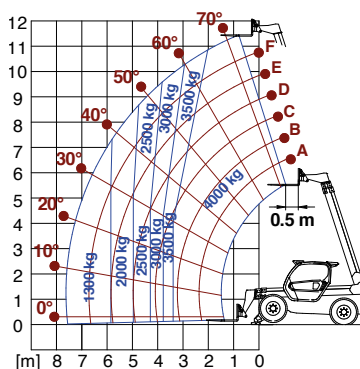

P40.13

